

HOME MARINGÁ

V-6 15/06/23

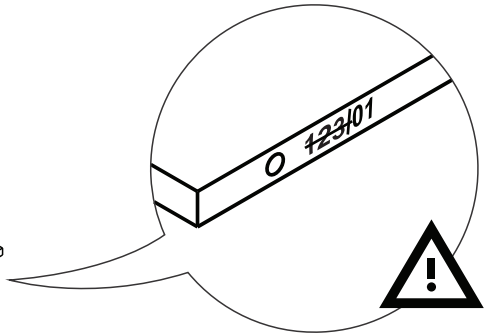
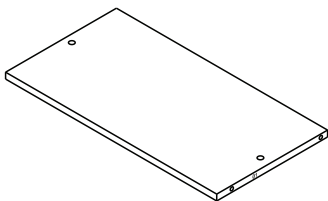
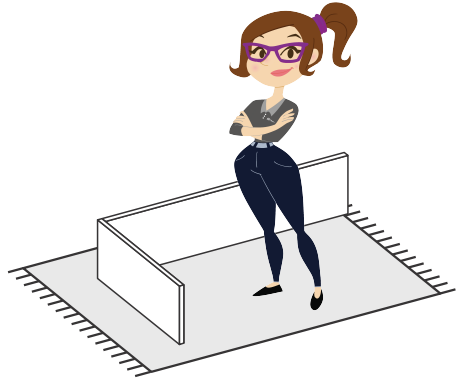
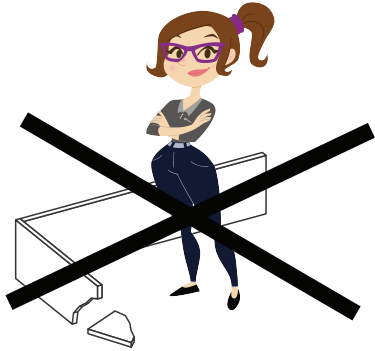
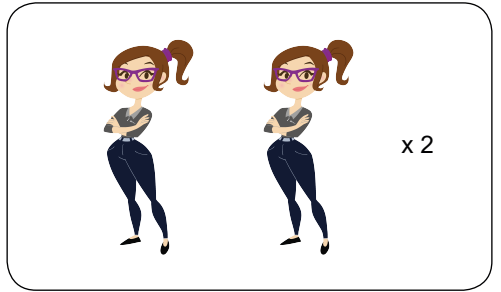
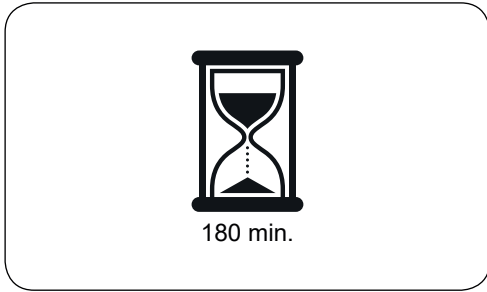
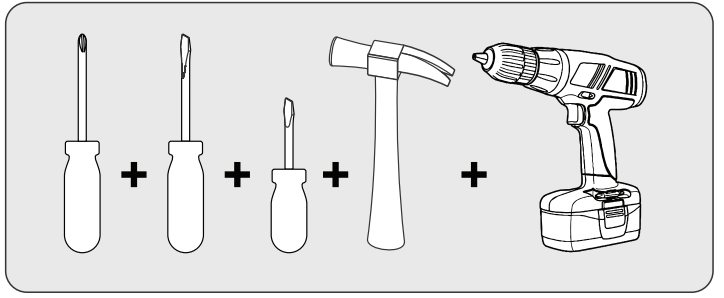
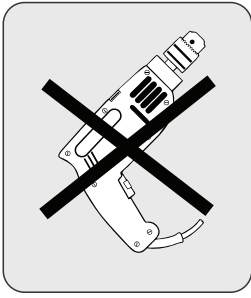

GARANTIA / GARANTIA / WARRANTY

Nossos produtos são garantidos por 90 dias contra defeitos de fabricação. Ao constatar um problema coberto pela garantia, entre em contato com a loja onde o produto foi comprado. Ela estará capacitada para atendê-lo da melhor forma diante de cada caso. Reclamações de garantia somente poderão ser atendidas se o termo de garantia for apresentado no ato de reivindicá-lo, acompanhado de sua nota fiscal de compra.

Nuestros productos están garantidos contra defectos de fabricación por 90 días, a partir de la compra. Ao constatar un problema protegido por la garantía, póngase en contacto con la tienda donde se adquirió el producto. Ella estará capacitada para atenderlo de la mejor manera de acuerdo con cada caso.

Our products are guaranteed against manufacturing defects for 90 days from the date of purchase. When you find a problem covered by the warranty, please contact the store where the product was purchased. The store is able to serve you in the best way in each case.

Exclusões

- Desgaste natural ou danos causados por água, maresia, ferrugem, incêndio, calor, cupins e pragas em geral.
- Montagem, manutenção e uso inadequado.
- Não cumprimento das recomendações técnicas do esquema.
- Montagens e desmontagens após a primeira instalação.
- Instalações elétricas e outras afins.

Exclusiones

- Desgaste natural o daños causados por agua, maresia, incendios, calor, termitas y plagas en general.
- Montaje, mantenimiento y uso inadecuado.
- No cumplimiento de las recomendaciones técnicas del esquema.
- Montaje y desmontaje después de la primera instalación.
- Instalaciones eléctricas y otras afines.

Exclusions

- Natural wear or damage caused by water, sea, rust, fire, heat, termites and plagues in general.
- Assembly, maintenance and improper use.
- Failure to comply with the technical recommendations of the assembly instructions.
- Assembly and disassembly after first installation.

Importante

A Linha Brasil não autoriza nenhuma pessoa, loja ou entidade assumir em seu nome qualquer outra garantia que não conste no certificado. A fabricante reserva-se no direito de efetuar nos produtos eventuais modificações que considerar necessárias, sem prejudicar as características essenciais. Os produtos terão peças de assistência para reposição no período de 1 ano a contar de sua retirada do mercado, desde que haja matéria-prima equivalente, observando o dispositivo no Art.32 da Lei 8.078/90 (Cód. Defesa do Consumidor). O atendimento para produtos fora de linha é feito por programação especial, através da loja revendedora sob aprovação de consulta prévia ao fabricante.

Importante

Linea Brasil no autoriza a ninguna persona, tienda o entidad a asumir en su nombre cualquier otra garantía que no figure en el certificado. El fabricante se reserva el derecho de efectuar en los productos eventuales modificaciones que considere necesarias, sin perjudicar las características esenciales. Los productos tendrán piezas de asistencia para reposición en el período de 1 año a partir de su retirada del mercado. La atención para productos fuera de línea es hecha por programación especial, a través de la tienda revendedora bajo aprobación de consulta previa al fabricante.

Important

Linea Brasil does not authorize any person, store or entity to assume on its behalf any other warranty that does not appear on the certificate. The manufacturer reserves the right to make in the products any modifications that it considers necessary without prejudice to the essential characteristics. The products will have replacement parts within one year of being withdrawn from the market. The service for off-line products is done by special programming, through the store reseller under prior consultation with the manufacture.

INSTRUÇÕES DE LIMPEZA E CONSERVAÇÃO

INSTRUCCIONES PARA LA LIMPIEZA E CONSERVACION / CLEAN AND PRESERVATION INSTRUCTURE

Para retirar o pó, utilize um pano seco, espanador ou aspirador. Se necessário, para uma limpeza mais efetiva, utilize um pano levemente umedecido com água. Finalize com uma flanela limpa e seca.

Para eliminar el polvo, utilice un paño seco, mopa o la aspiradora. Si es necesario, para una limpieza más eficaz, utilice un paño ligeramente humedecido con agua. Terminar con un paño limpio y seco.

To take dirty, use a dry cloth, duster or vacuum. If necessary to take the dust, use a wet cloth. Finish with a clean and dry flannel.

IMPORTANTE / IMPORTANTE / IMPORTANT



Não utilize produtos abrasivos como álcool e detergentes, como também esponjas rígidas ou palha de aço na limpeza dos móveis.
No use limpadores abrasivos como alcohol y detergentes, así como esponjas rígidas o lana de acero para limpiar los muebles.
Do not use abrasives such as alcohol and detergent, taugh soaker also steel wool to clean the furniture.



Proteja a superfície do móvel de objetos que transmitam calor ou umidade.
Proteja la superficie del mueble de objetos que transmitan calor o humedad.
Protect the surface of the furniture against objects that can pass heat and humidity.



Evitar o contato de água e produto de limpeza com o rodapé do produto, pois poderá danificá-lo.
Evitar el contacto con agua y producto de limpieza con el rodapé del producto, pues poderá dañarlo.
Avoid the contact of water and cleaning products with baseboard, cause it should damage your product.



Procure sempre utilizar flanela limpa e seca para a limpeza.
Busque siempre utilizar franela limpia y seca para la limpieza.
Try always to use a clean and dry flannel to cleaning.



Cuidado com objetos pontiagudos, eles podem arranhar a superfície das portas e tampo.
Cuidado con objetos afilados, ellos pueden rayar la superficie de las puertas e la tapa.
Take care with sharp objects, they can scratch the door/lid surface.

INSTRUÇÃO DE INSTALAÇÃO DE TELEVISORES

INSTRUCCIÓN DE INSTALACIÓN DE TELEVISIÓN / TELEVISION INSTALLATION INSTRUCTION

Para o uso do maior televisor indicado recomendamos a instalação da TV no painel do produto.
Para utilizar el televisor más grande indicado, recomendamos la instalación del televisor en el panel del producto.
To use the largest television indicated, we recommend installing the TV on the product panel.

TAMANHO DE TV SUGERIDO

TAMANHO DE TELEVISOR SUGERIDO
SUGGESTED TV SIZE

45"

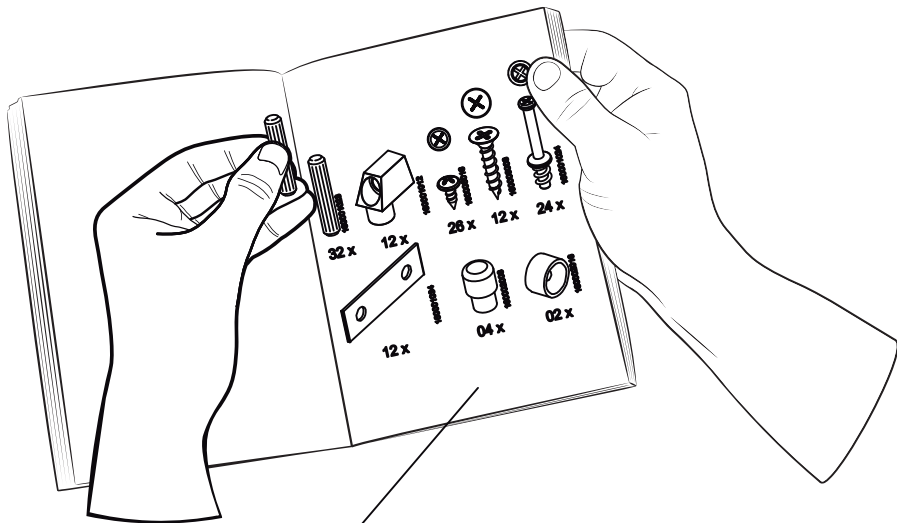

Preste Atenção! ¡Preste atención! Attention!



As ferramentas dos nossos manuais são sempre apresentadas nas mesmas proporções de peça na vida real.
Caso apareça alguma dúvida no decorrer do processo de montagem, coloque a ferragem ao lado do desenho e faça a consulta :D

Los accesorios de nuestros manuales siempre se presentan en las mismas proporciones que la pieza en la vida real. Si tiene alguna duda durante el proceso de montaje, coloque los accesorios junto al dibujo y haga una consulta :D

The accessories in our manuals are always presented in the same proportions as the spare part in real life. If you have any questions during the assembly process, place the accessory next to the drawing and make an inquiry :D

Símbolos: Símbolos: Symbols:



- + Parafuso Phillips
- Parafuso Fenda
- ⬡ Parafuso Allen

- + Tornillo Phillips
- Tornillo Ranurado
- ⬡ Tornillo Allen

- + Phillips screw
- Slotted Screw
- ⬡ Allen screw

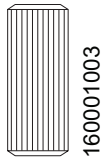

160001003

12 x

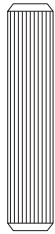

160001023

26 x

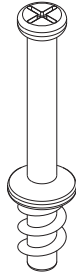

160001024

36 x

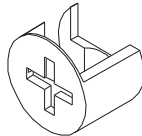

160001025

36 x

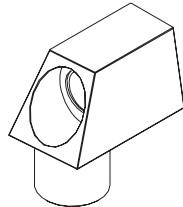

160001012

07 x

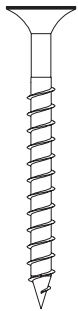

160006006

06 x



160006008

31 x

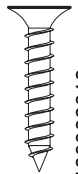

160006018

34 x



160006044

02 x



160006003

02 x



160006016

186 x



160002015

04 x

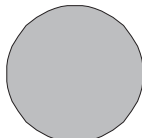

160002002

18 x

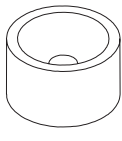

160002016

02 x

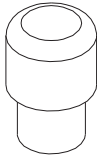

160002003

04 x

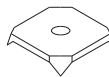

160001002

06 x

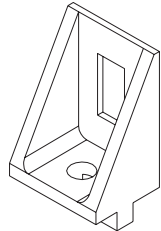

160001011

10 x

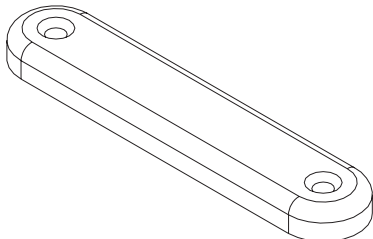

160002004

08 x



160006011

64 x

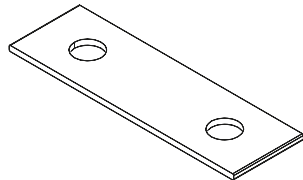

160001034

15 x

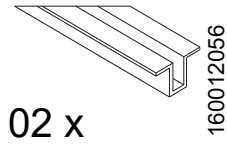
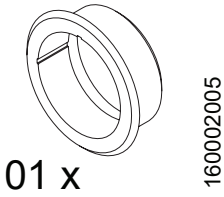
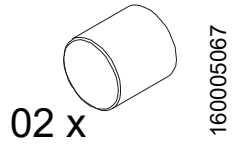
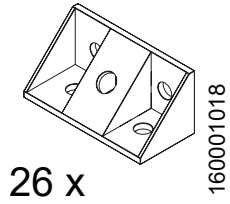
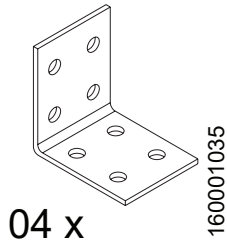
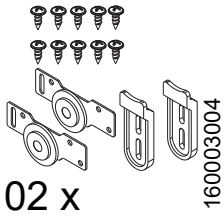

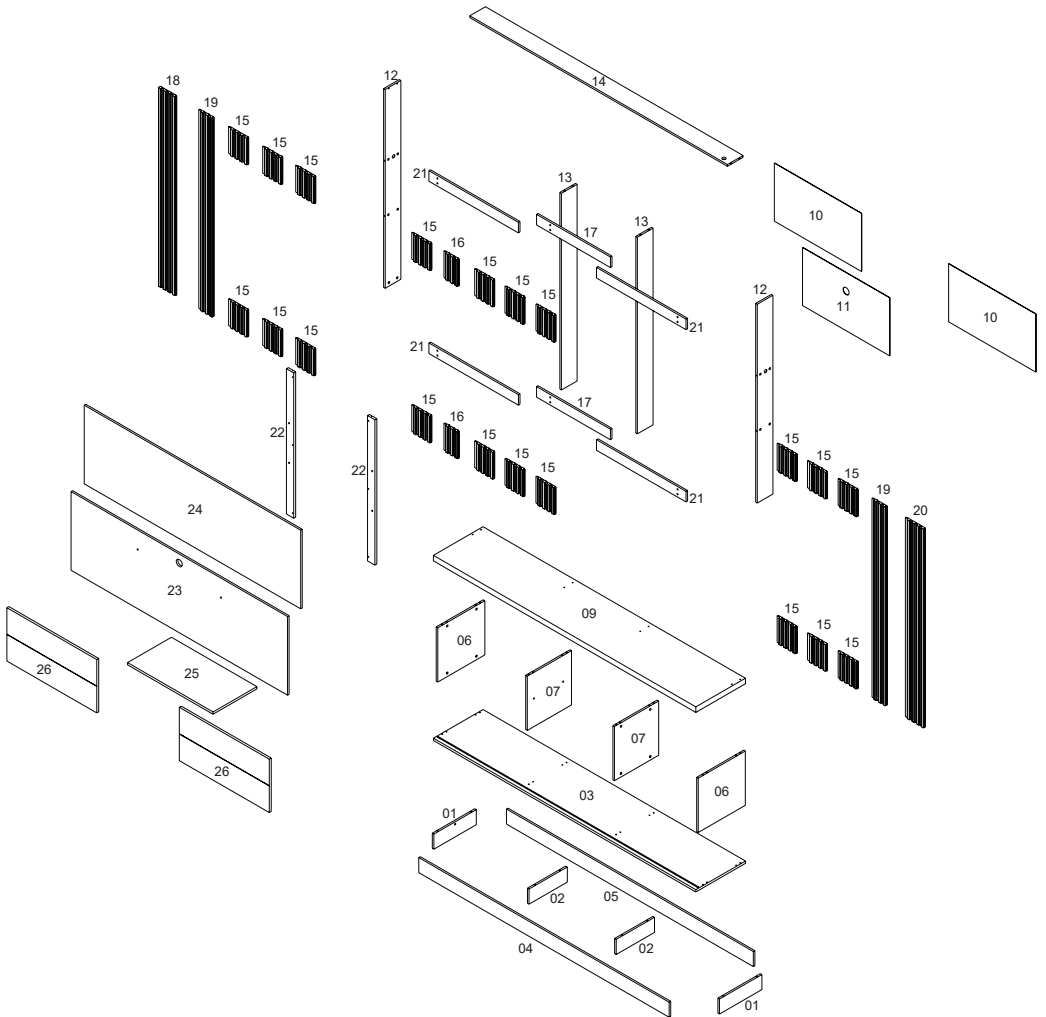

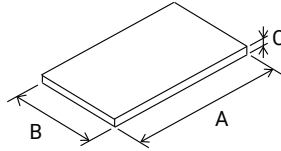

VOLUME Caja Box	ITEM Artículo Item	PEÇA Pieza Part	DESCRIÇÃO Descripción Description	DIMENSÕES (mm) Dimensión/Dimension			QUANTIDADE La Cantidad The Amount	MATERIAL
				A	B	C		
1	1	510271001	RODAPE LATERAL	324	100	12	2	MDP
1	2	510271002	RODAPE CENTRAL	293	100	12	2	MDP
1	3	510271003	BASE	2012	381	15	1	MDP
1	4	510271004	RODAPE FRONTAL	1920	100	12	1	MDP
1	5	510271005	RODAPE TRASEIRO	1892	100	12	1	MDP
1	6	510271006	LATERAL	360	357	12	2	MDP
2	7	510271007	DIVISAO	360	339	12	2	MDP
1	9	510271009	TAMPO TV	2012	381	37	1	MDP
2	10	510271010	FUNDO LATERAL	668	385	2.8	2	MDF
2	11	510271011	FUNDO CENTRAL (COM FURO)	668	385	2.8	1	MDF
2	12	510271012	TRAVESSA LATERAL	1319	120	12	2	MDP
2	13	510271013	TRAVESSA CENTRAL	1305	120	12	2	MDP
1	14	510271014	TRAVESSA SUPERIOR	1978	120	12	1	MDP
2	15	510271015	MOLDURA CENTRAL 4 PICOS	177	147	15	20	MDF
2	16	510271016	MOLDURA CENTRAL 3 PICOS (COM FURAÇÃO)	177	110	15	2	MDF
1	17	510271017	TRAVESSA APOIO MOLDURA CENTRAL	566	70	12	2	MDP
2	18	510271018	MOLDURA LATERAL ESQUERDA	1320	127	15	1	MDF
2	19	510271019	MOLDURA LATERAL CENTRAL	1320	110	15	2	MDF
2	20	510271020	MOLDURA LATERAL DIREITA	1320	147	15	1	MDF
1	21	510271021	TRAVESSA APOIO MOLDURA LATERAL	686	70	12	4	MDP
2	22	510271022	TRAVESSA APOIO	964	56	15	2	MDP
2	23	510271023	PAINEL TV INFERIOR	1660	523	12	1	MDP
2	24	510271024	PAINEL TV SUPERIOR	1660	523	12	1	MDP
1	25	510271025	PRATELEIRA MOVEL	655	337	15	1	MDP
1	26	510271026	PORTA	690	354	15	2	MDP

ARTÍCULO	DESCRIPCIÓN
1	ZÓCALO LATERAL
2	ZÓCALO CENTRAL
3	BASE
4	ZÓCALO FRONTAL
5	ZÓCALO TRASERO
6	LATERAL
7	DIVISIÓN
9	BASE TV
10	FONDO LATERAL
11	FONDO CENTRAL (CON AGUJERO)
12	PLATO LATERAL
13	PLATO CENTRAL
14	PLATO SUPERIOR
15	MARCO CENTRAL 4 CIMAS
16	MARCO CENTRAL 3 CIMAS (CON AGUJERO)
17	PLATO DE APOYO DEL MARCO CENTRAL
18	MARCO LATERAL IZQUIERDO
19	MARCO CENTRAL LATERAL CENTRAL
20	MARCO LATERAL DERECHO
21	PLATO DE APOYO DEL MARCO LATERAL
22	PLATO APOYO
23	PANEL TV INFERIOR
24	PANEL TV SUPERIOR
25	ESTANTE MÓVIL
26	PUERTA

ITEM	DESCRIPTION
1	SIDE BASEBOARD
2	CENTRAL BASEBOARD
3	BASE
4	FRONT BASEBOARD
5	BACK BASEBOARD
6	SIDE
7	DIVISION
9	BASE TV
10	SIDE BACK
11	CENTRAL BACK (WITH HOLE)
12	SIDE PLATE
13	CENTRAL PLATE
14	UPPER PLATE
15	CENTRAL FRAME 4 PEAKS
16	CENTRAL FRAME 3 PEAKS WITH HOLE
17	CENTRAL SUPPORT PLATE FRAME
18	LEFT FRAME
19	CENTRAL SIDE FRAME
20	RIGHT FRAME
21	SIDE SUPPORT PLATE FRAME
22	SUPPORT PLATE
23	LOWER PANEL
24	UPPER PANEL
25	MOBILE SHELF
26	DOOR

1

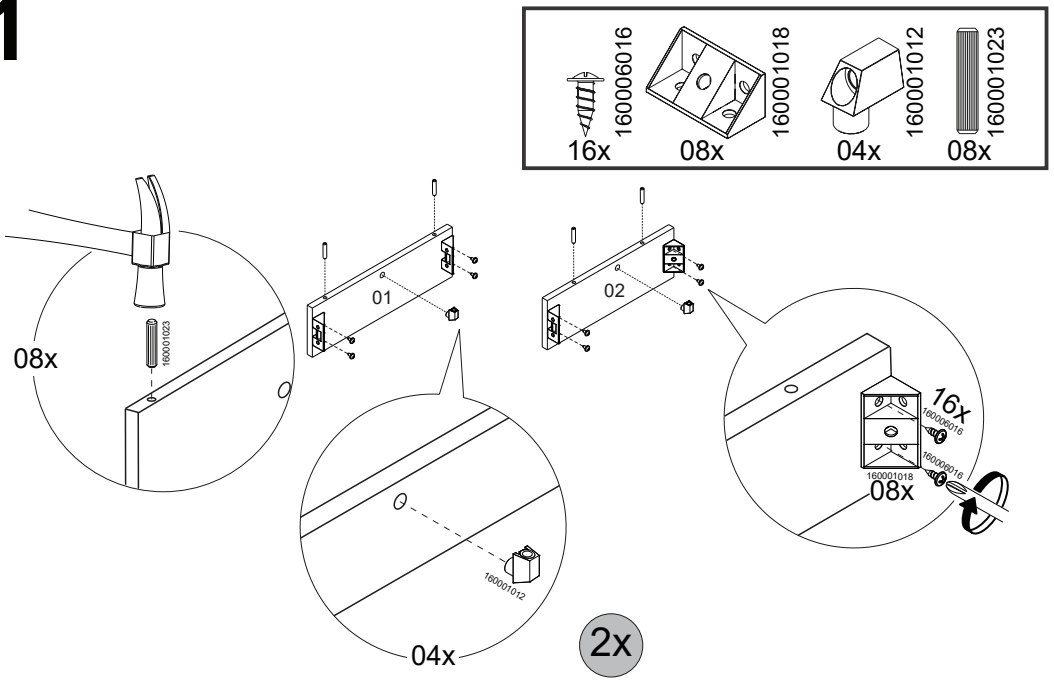

2

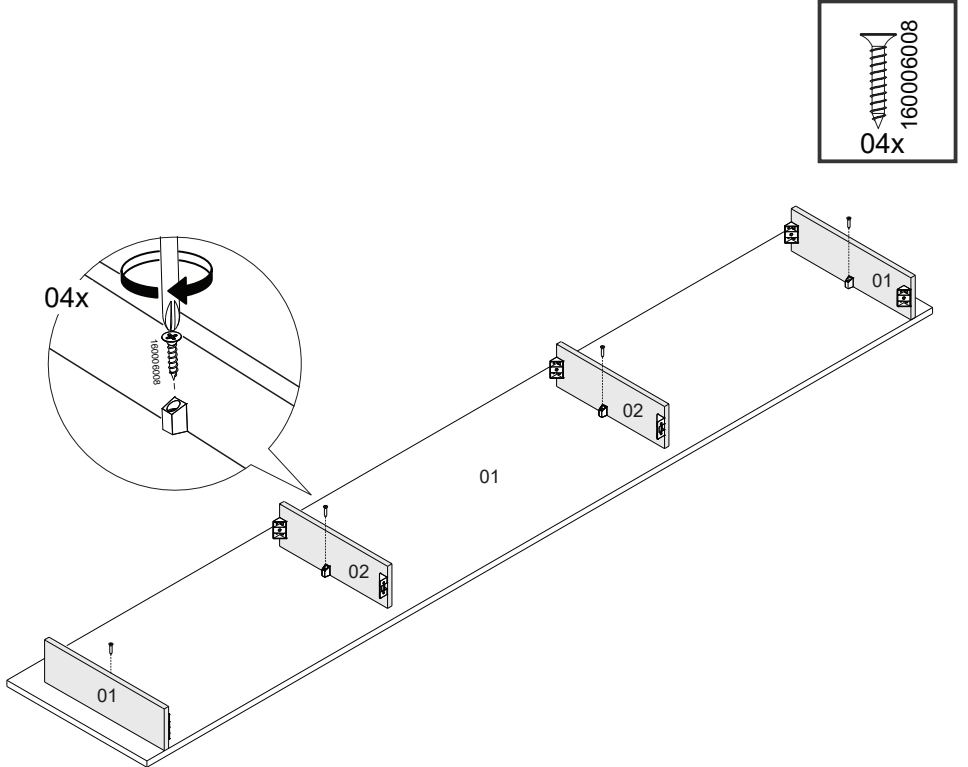

3

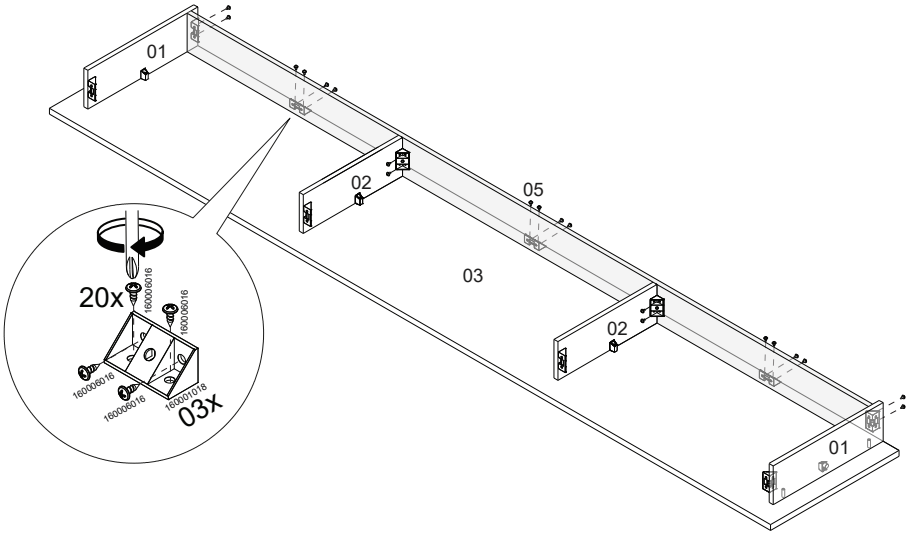
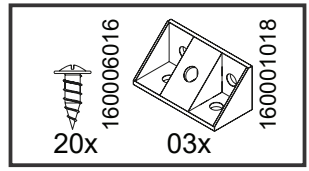

4

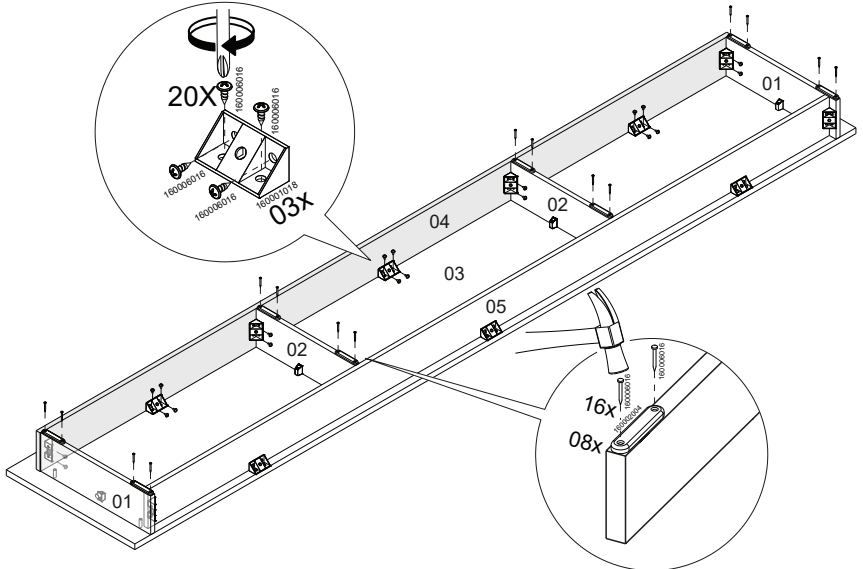
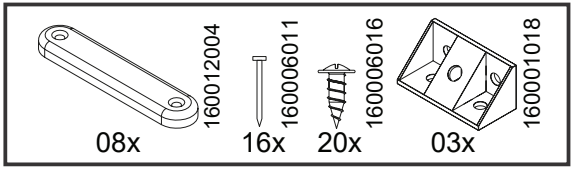

5

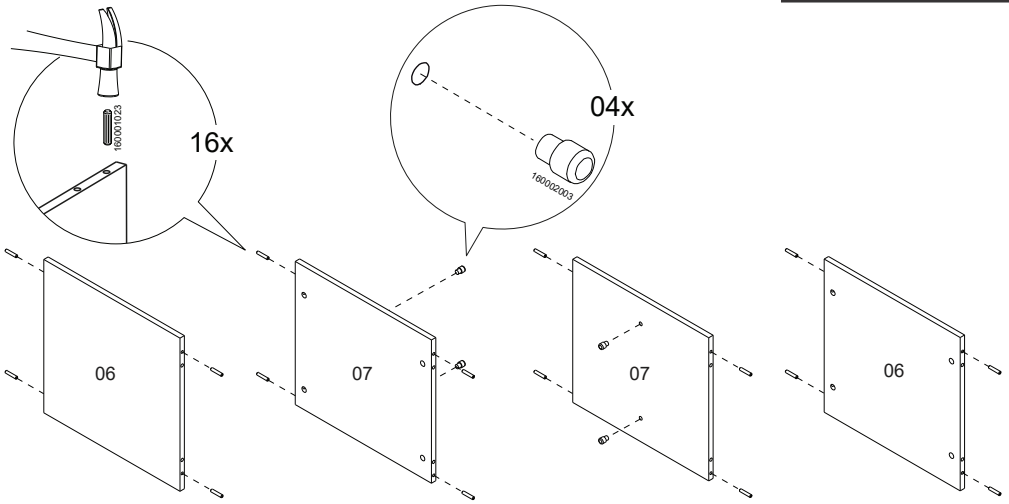
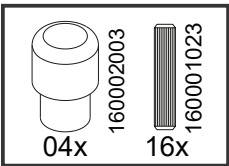

6

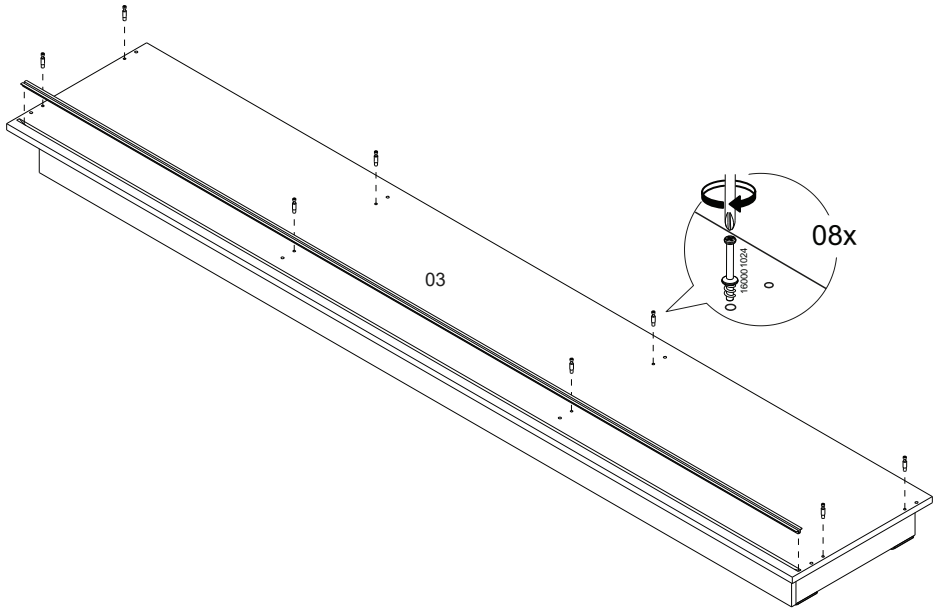
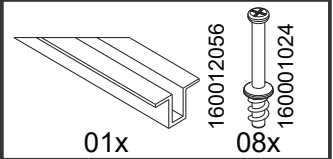

7

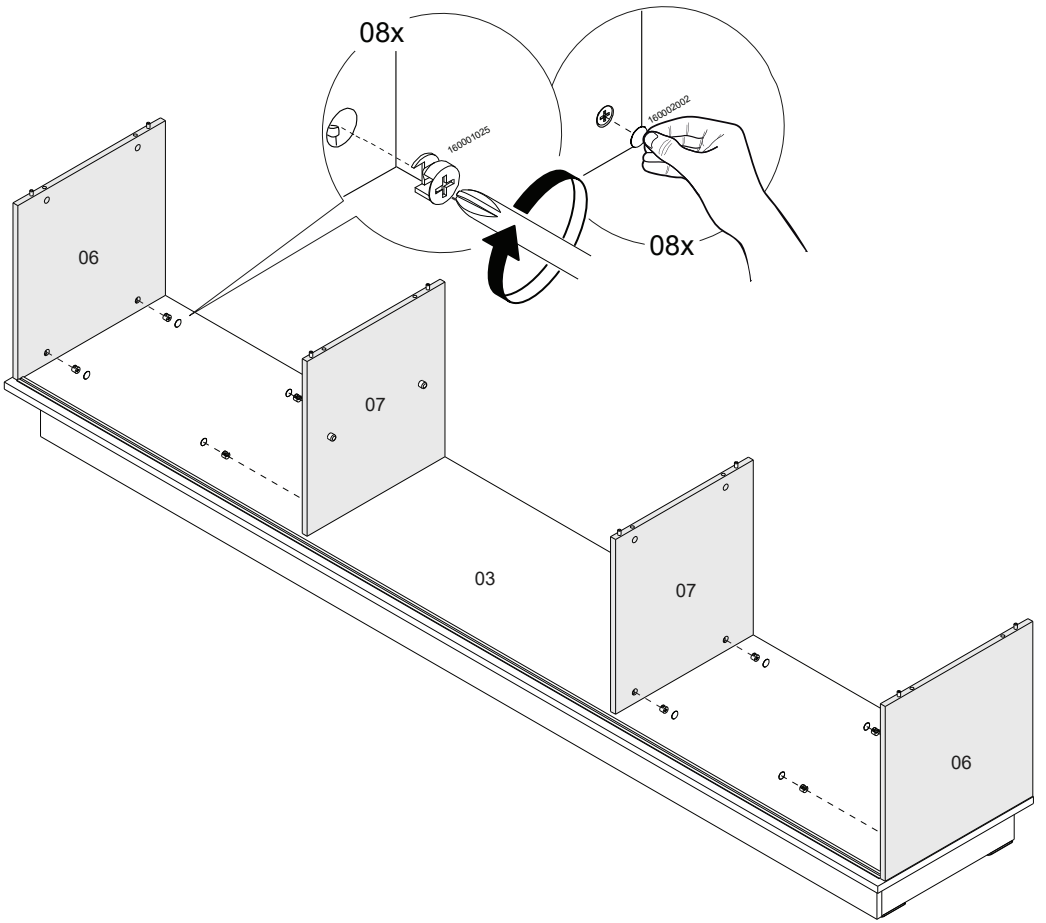
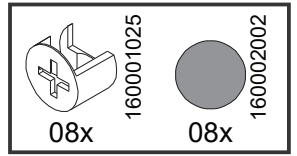
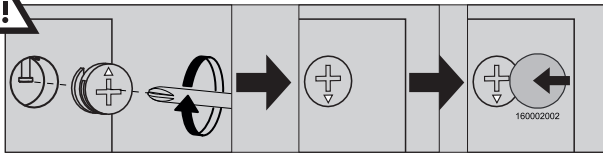

8

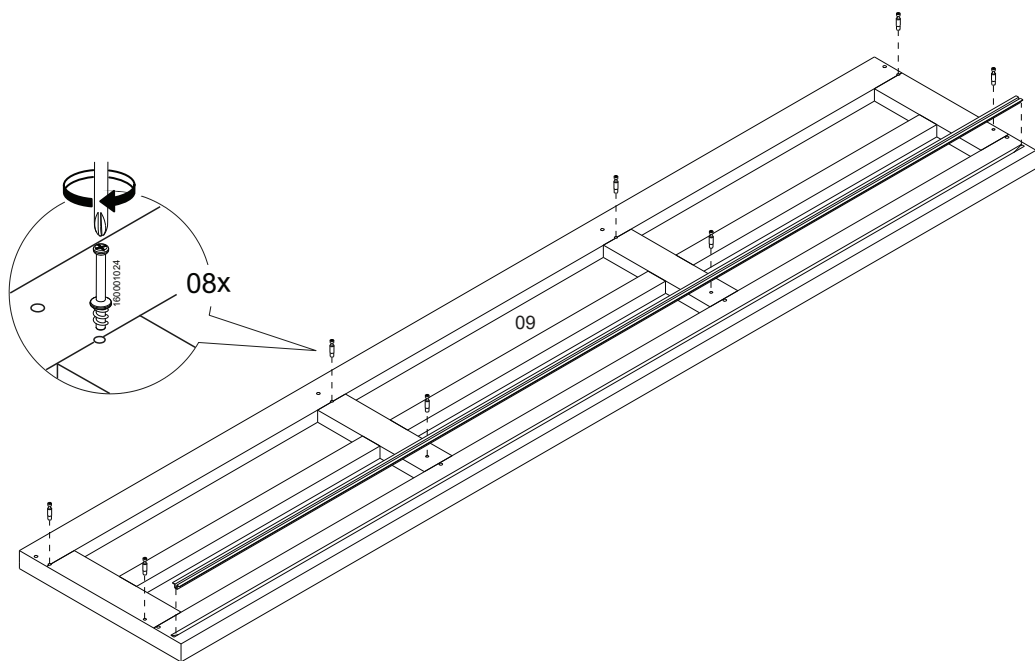
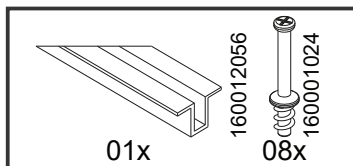

9

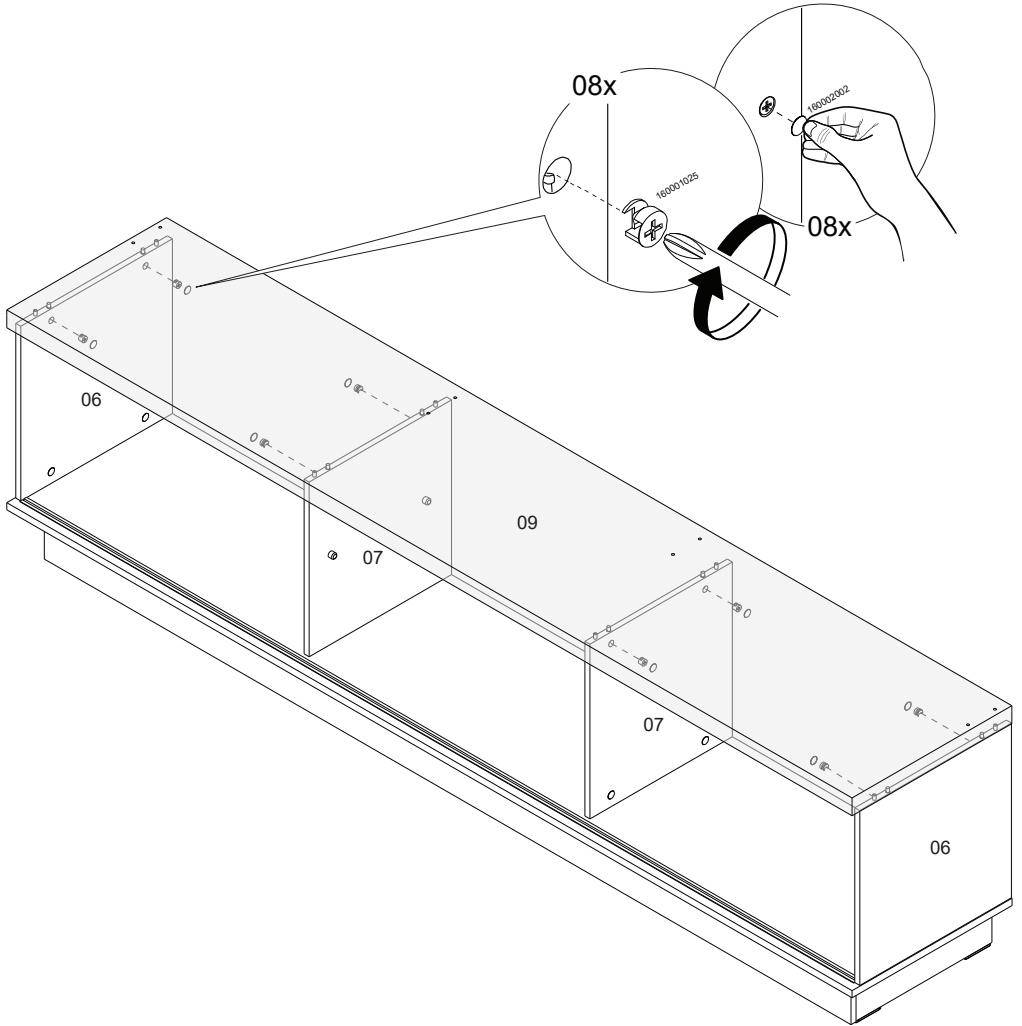
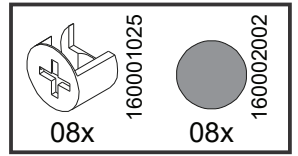
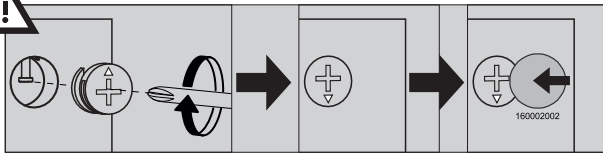

10

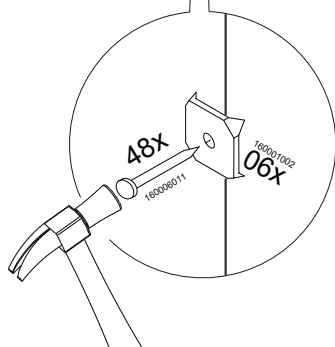
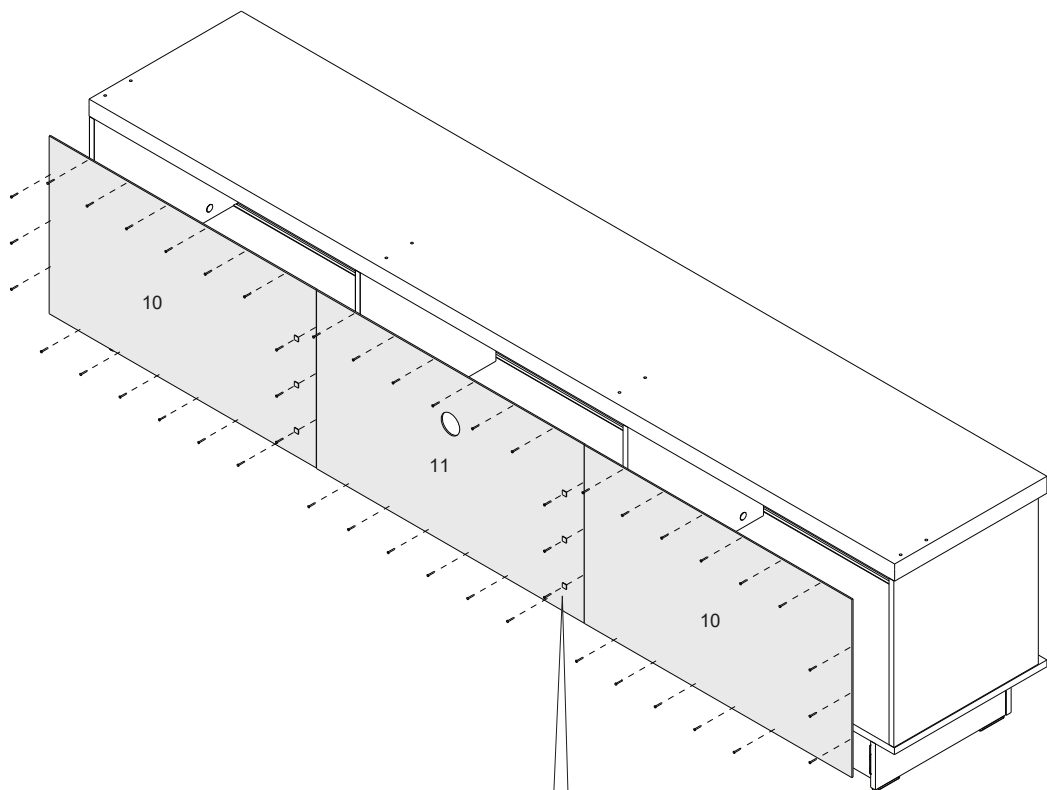
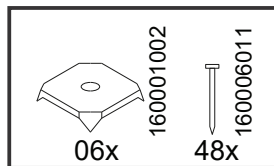

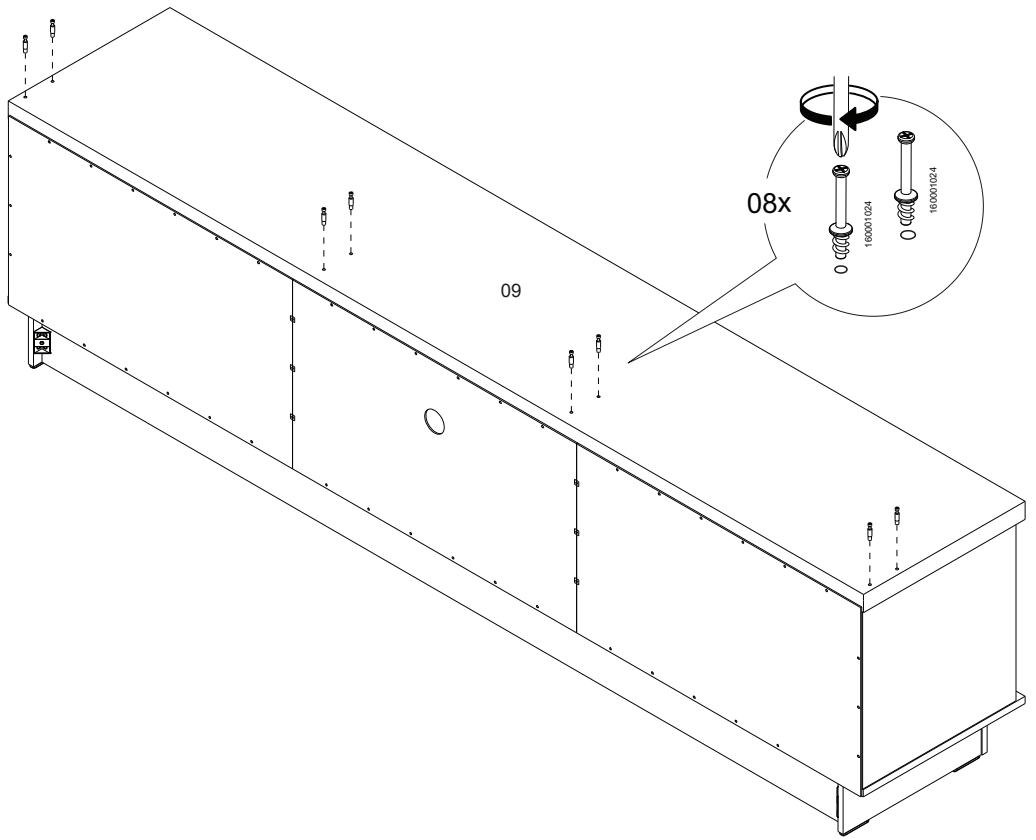
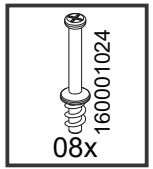

12

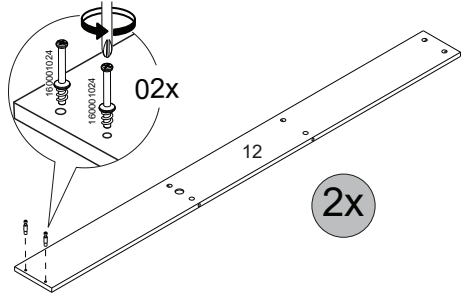
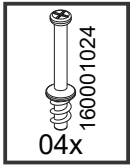

13

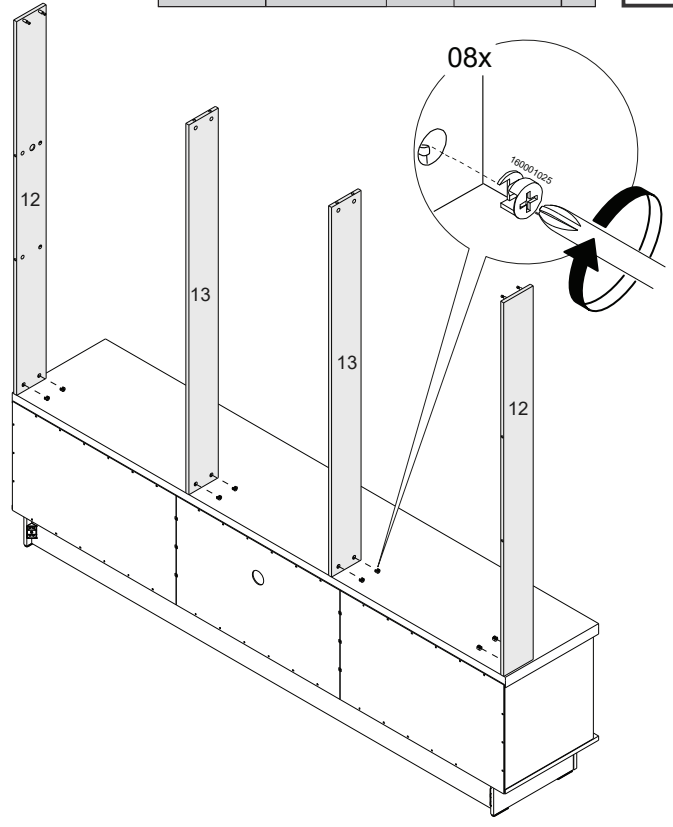
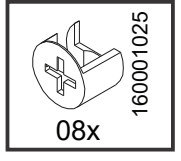
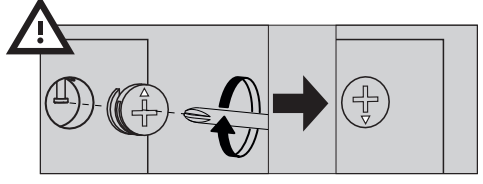

14

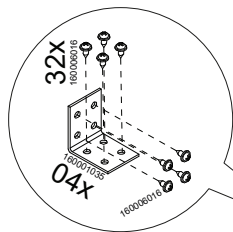
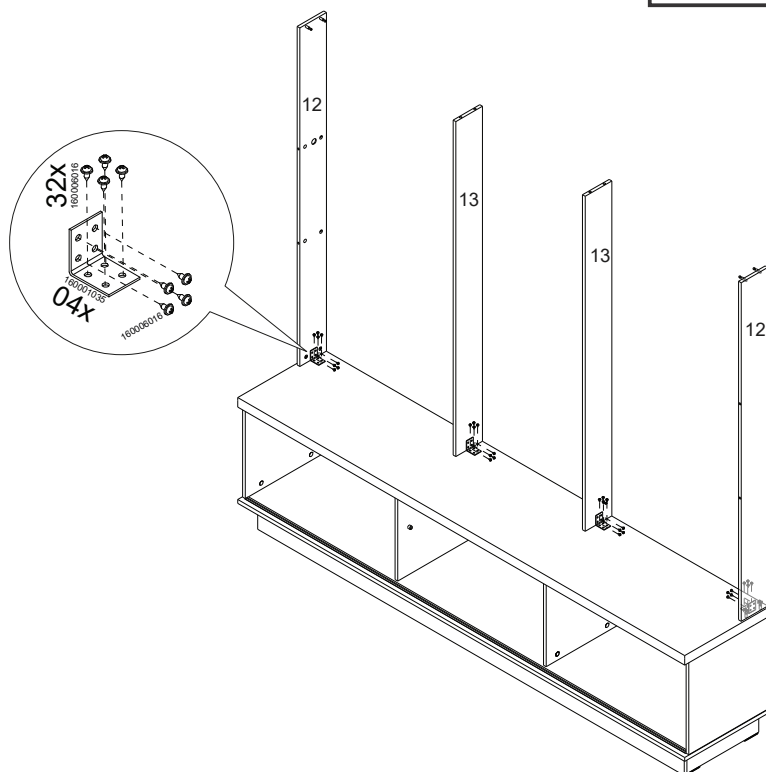
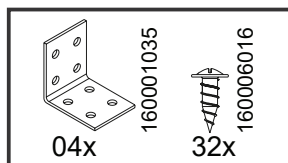

15

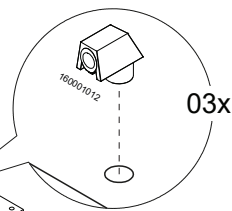
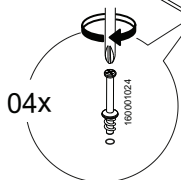
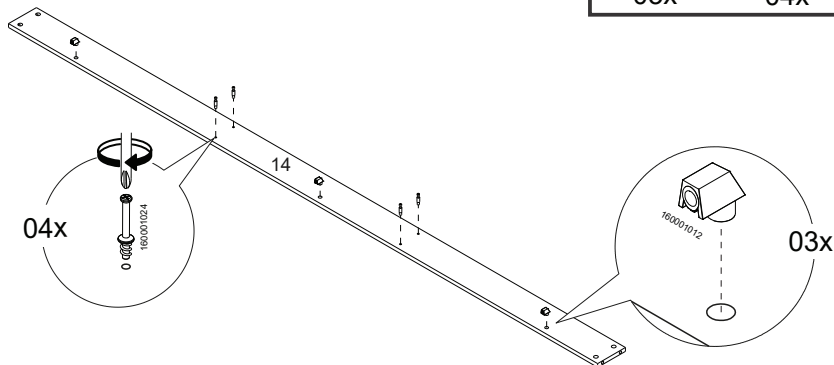
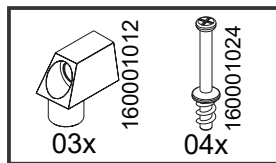

16

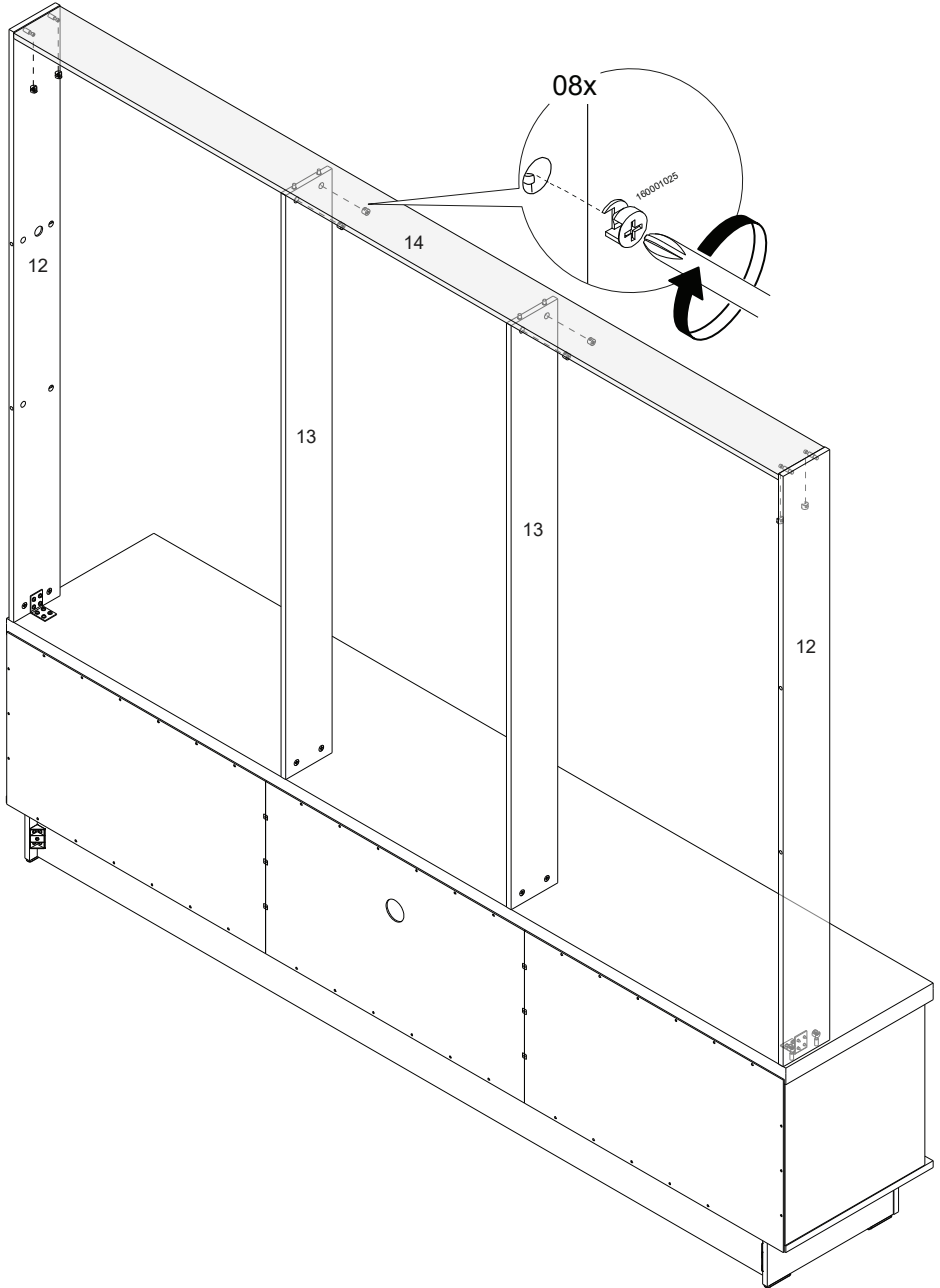
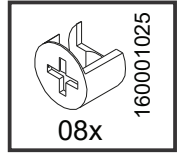
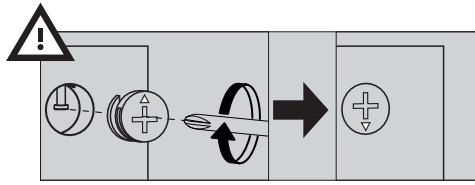

17

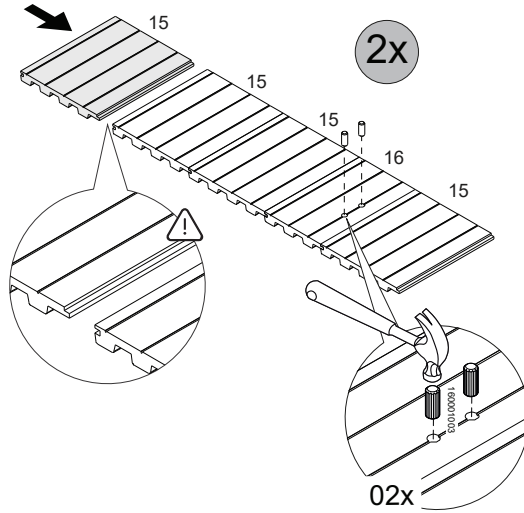
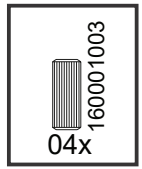
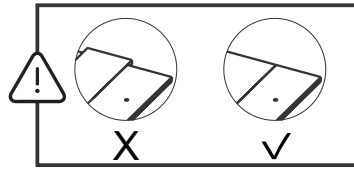

18

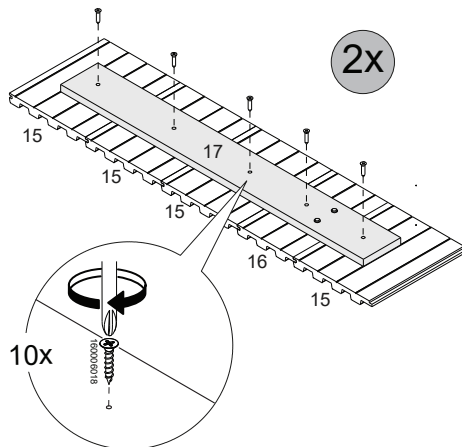
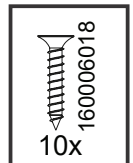

19

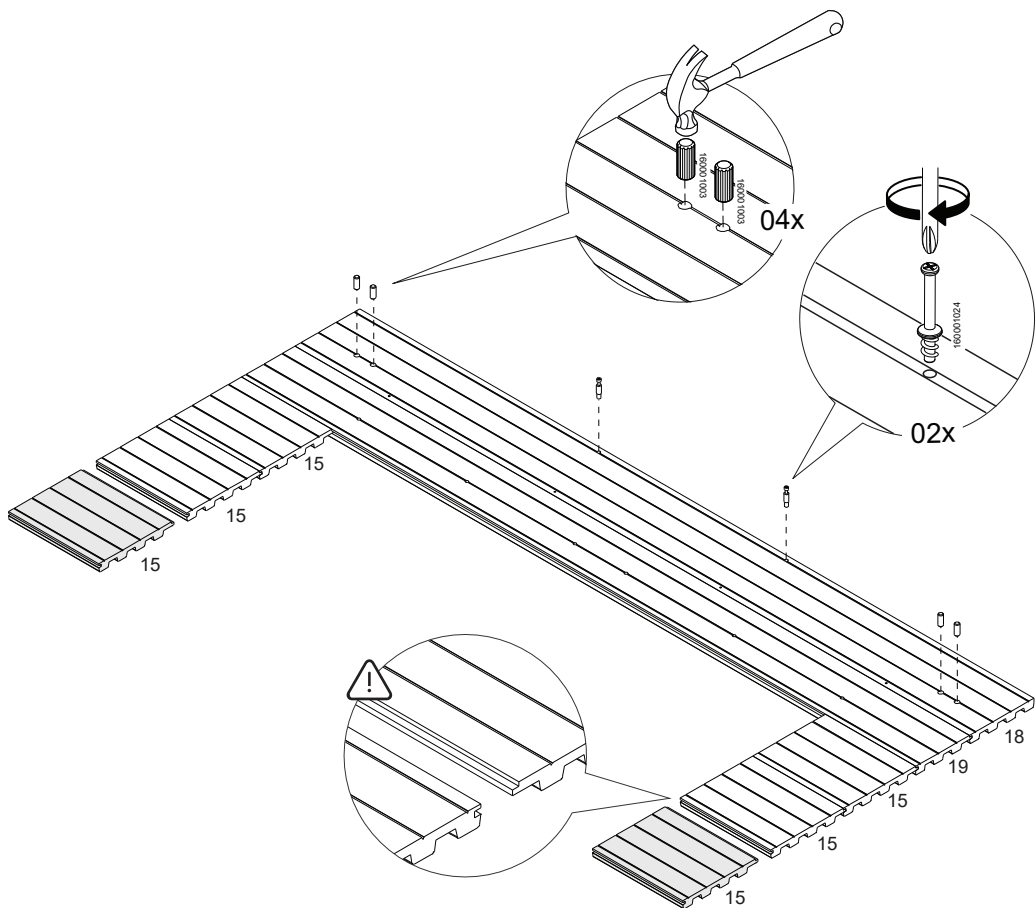
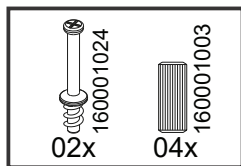

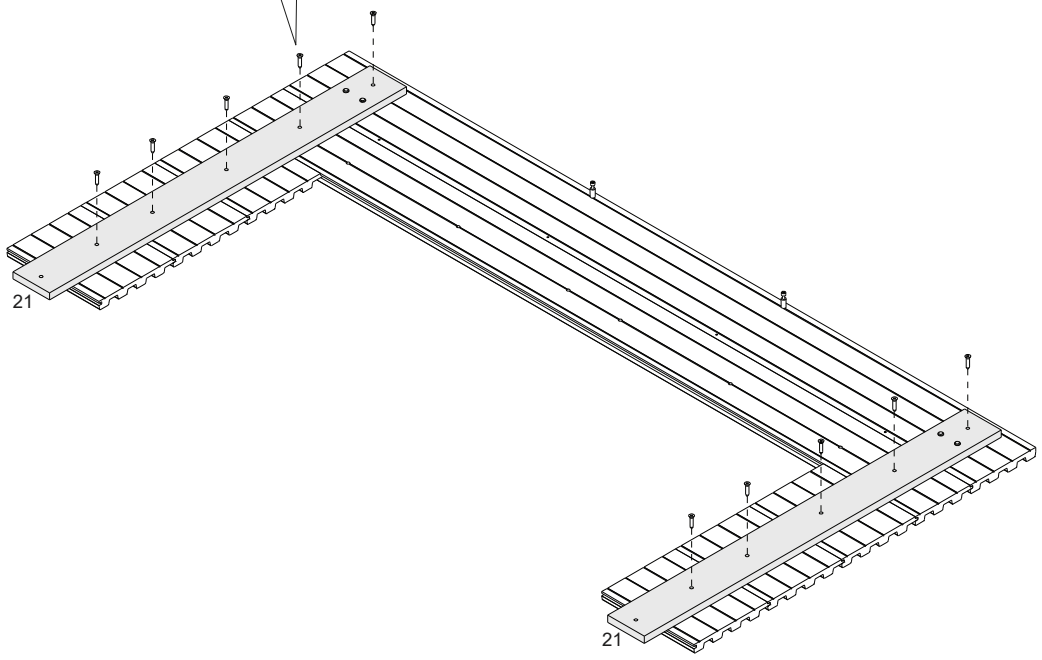
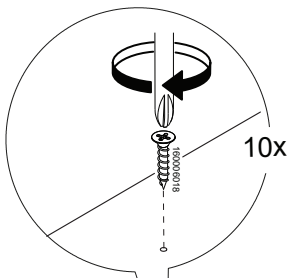
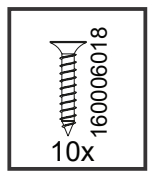

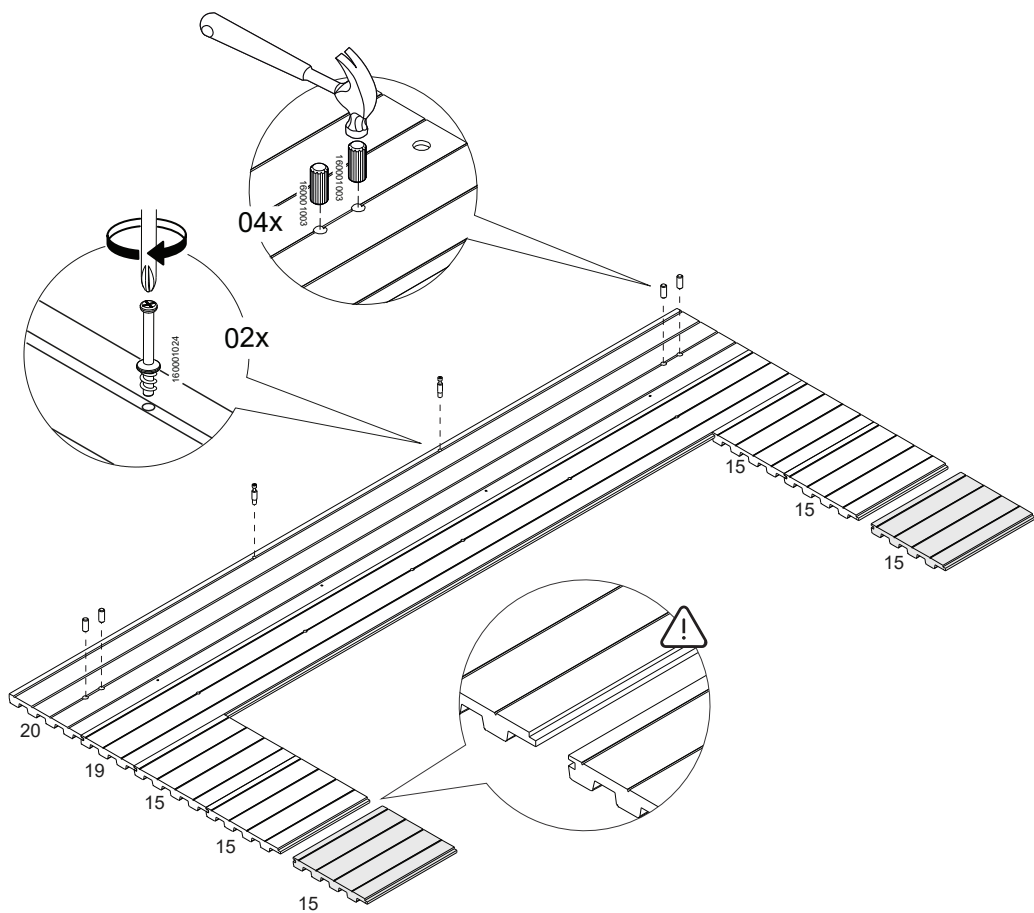
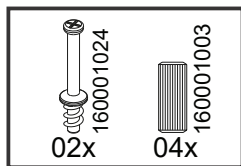

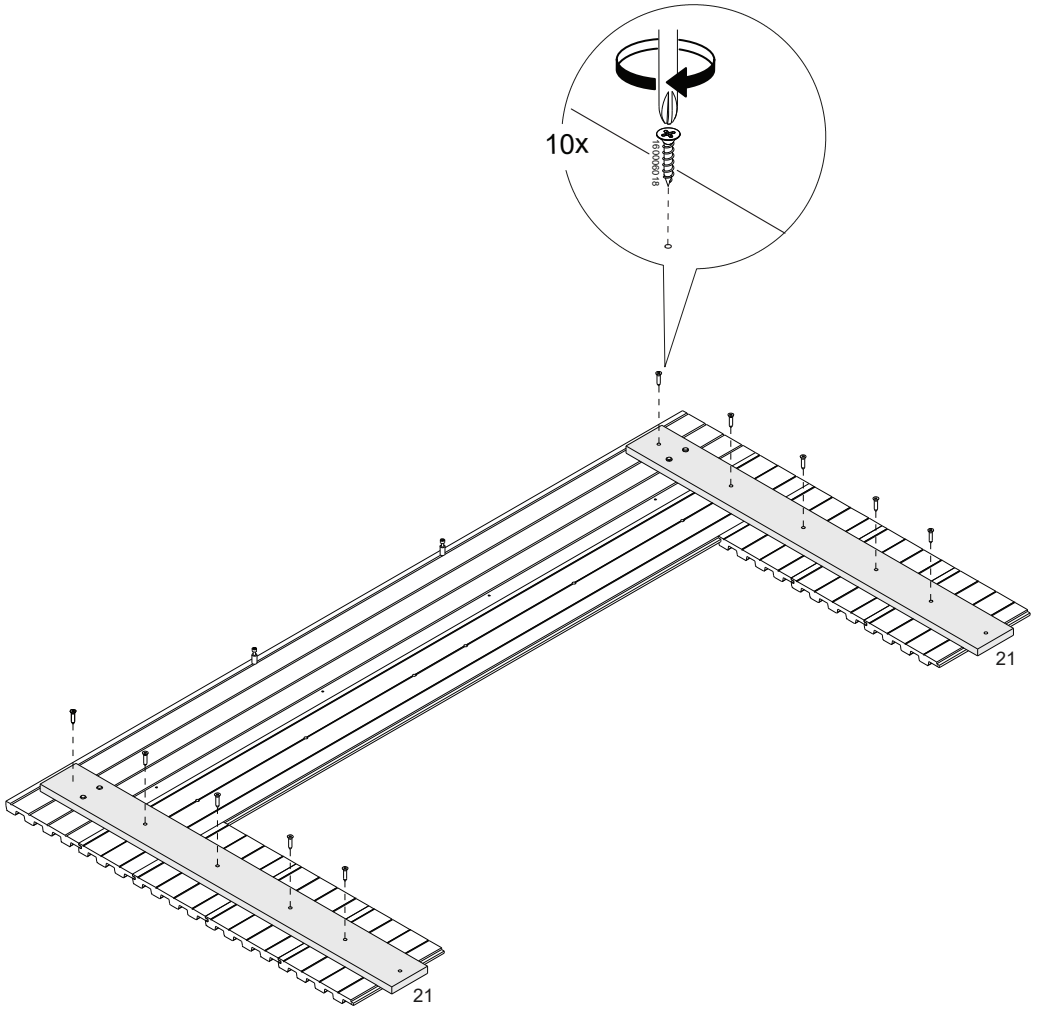
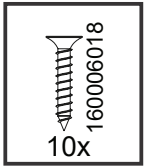

23

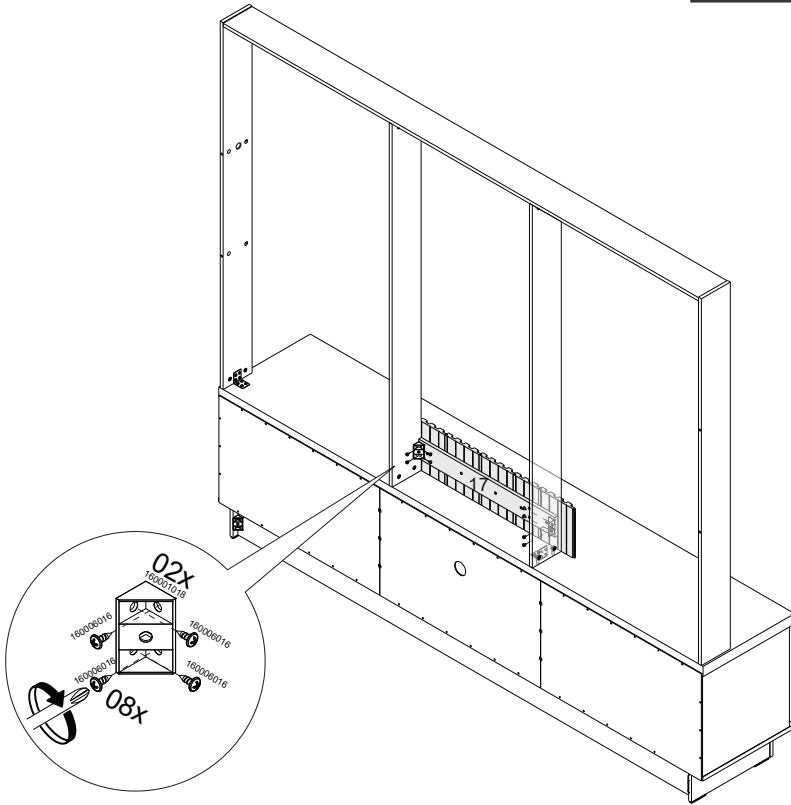
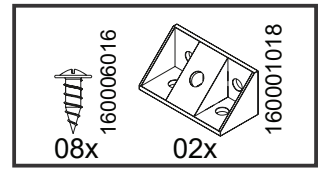

24

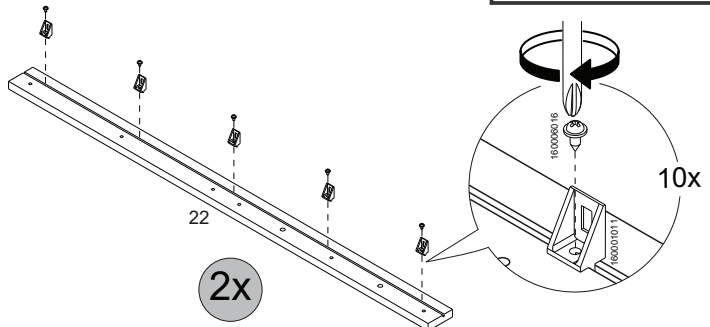
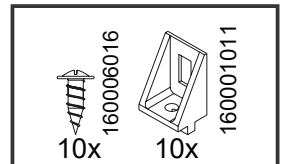

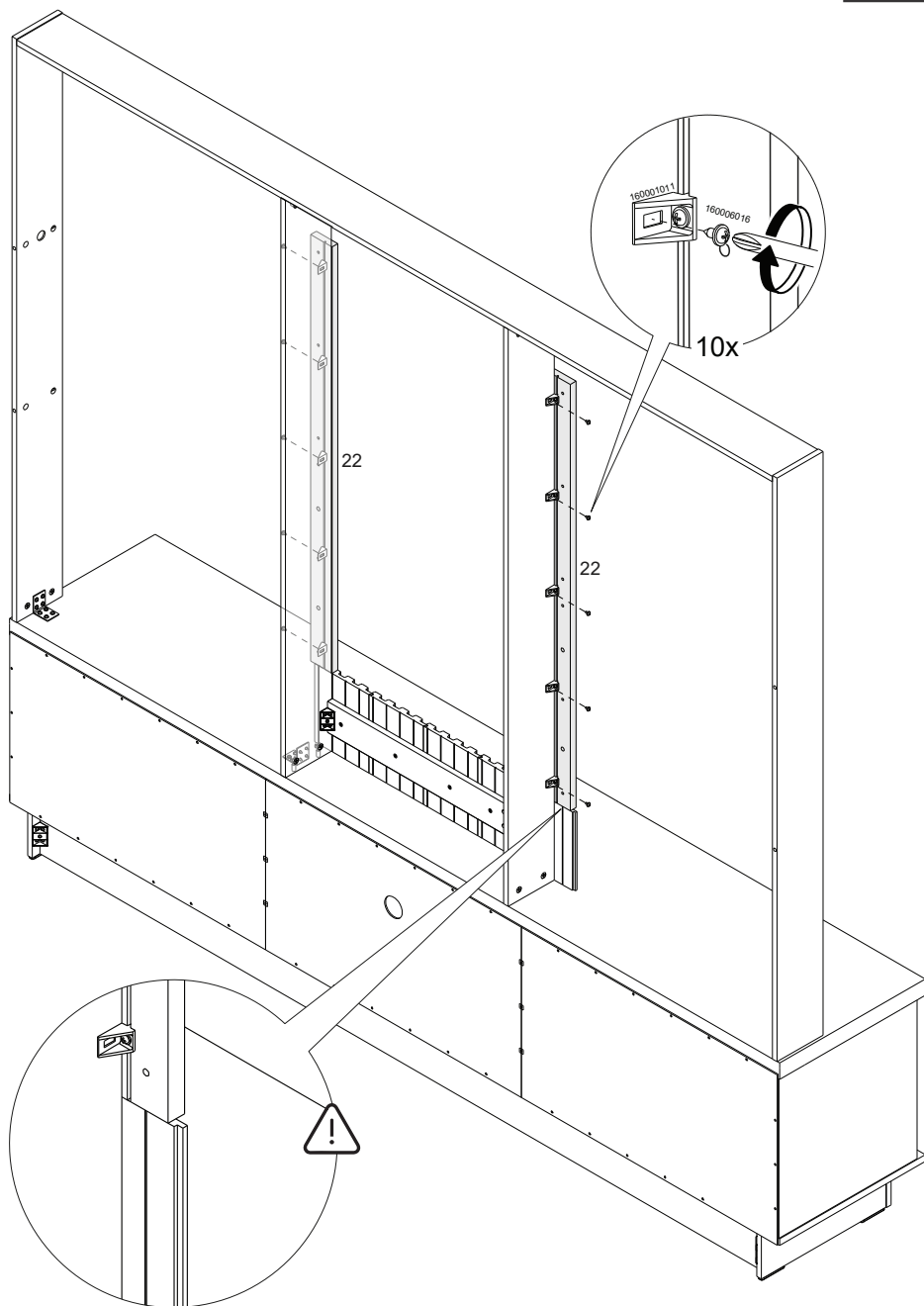
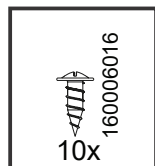



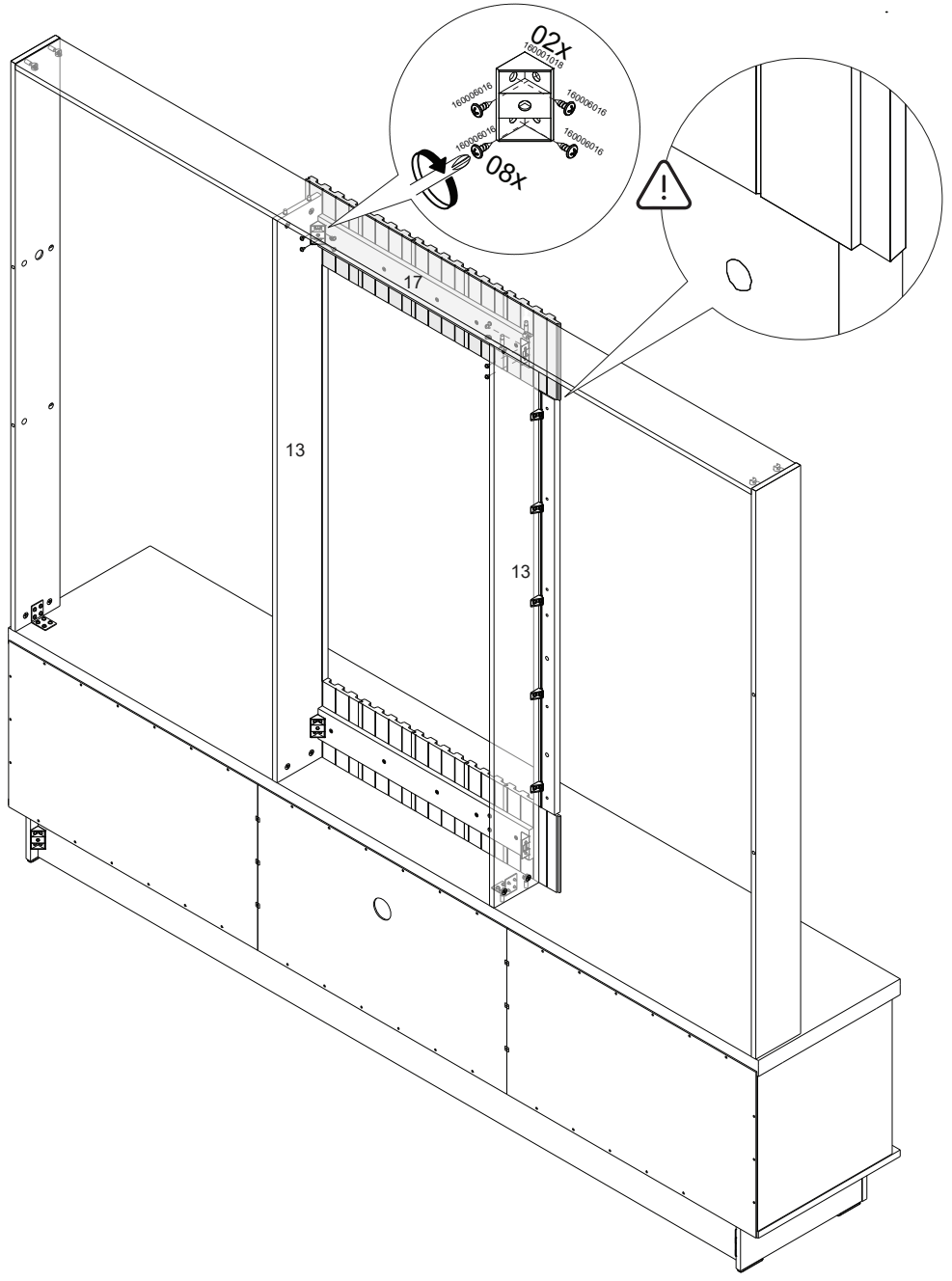
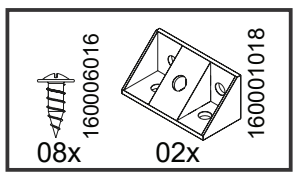

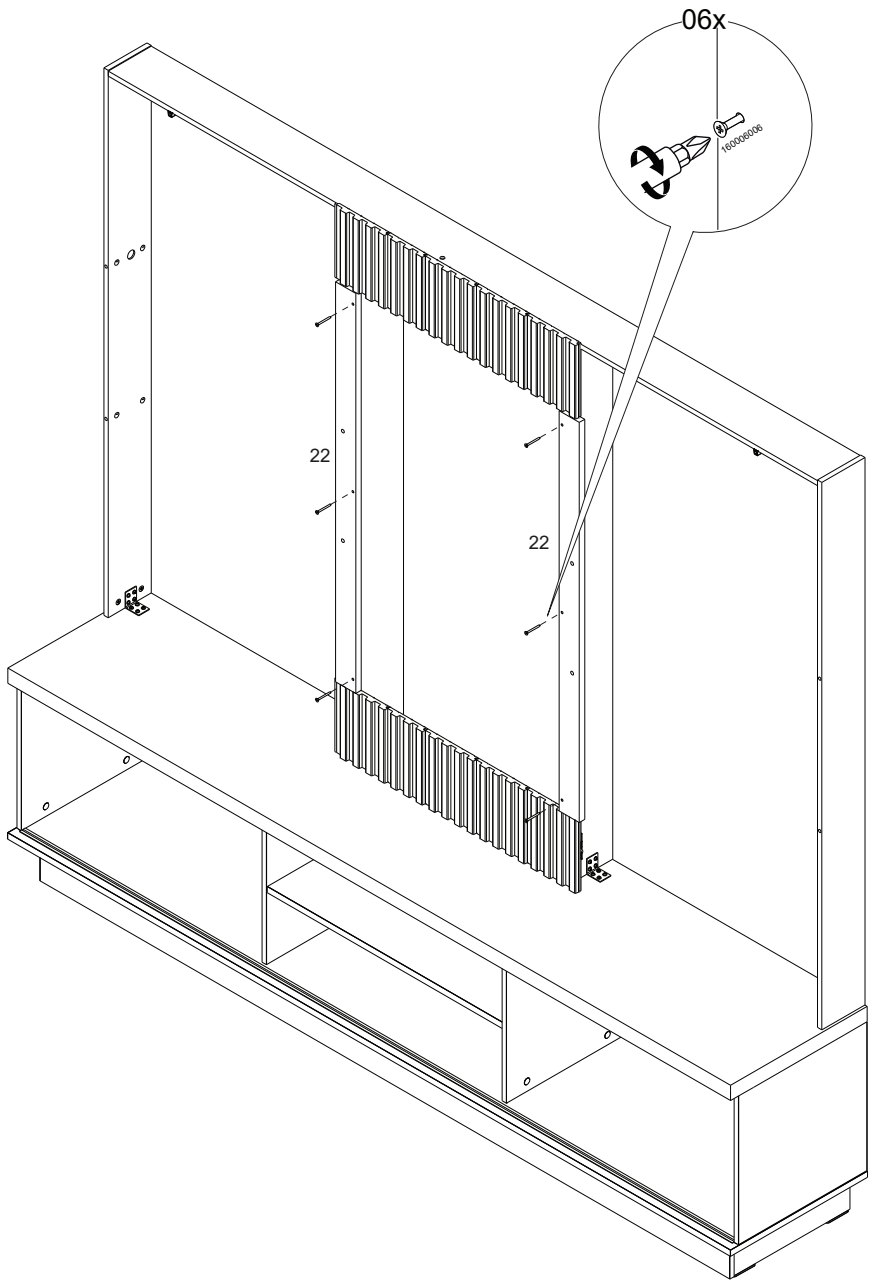
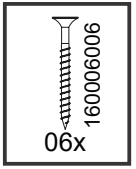

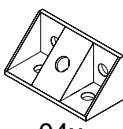

26



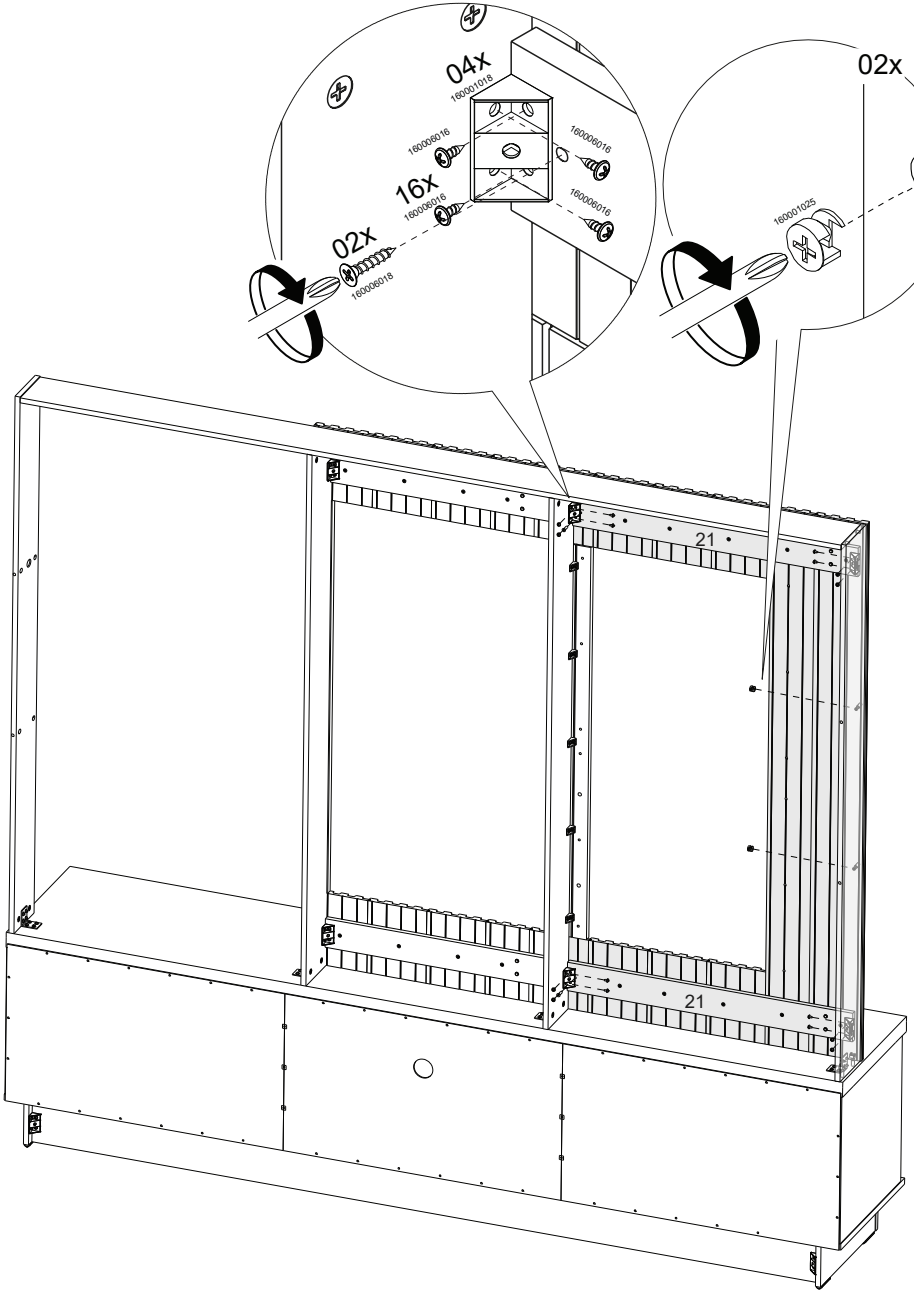

	160001025		160006016		160001018		160006018
02x		16x		04x		02x	

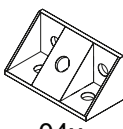

	160001025		160006016		160001018		160006018
02x		16x		04x		02x	

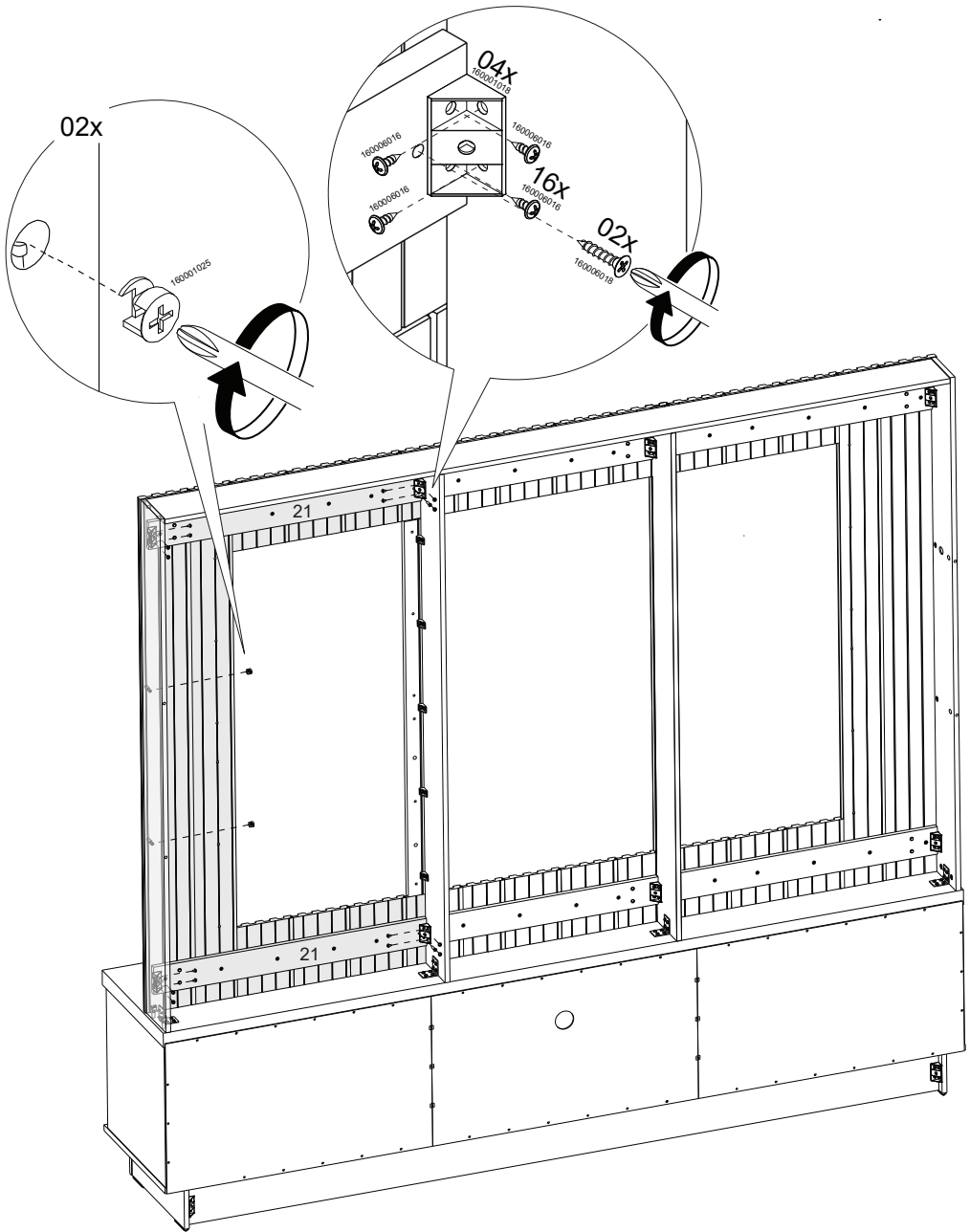

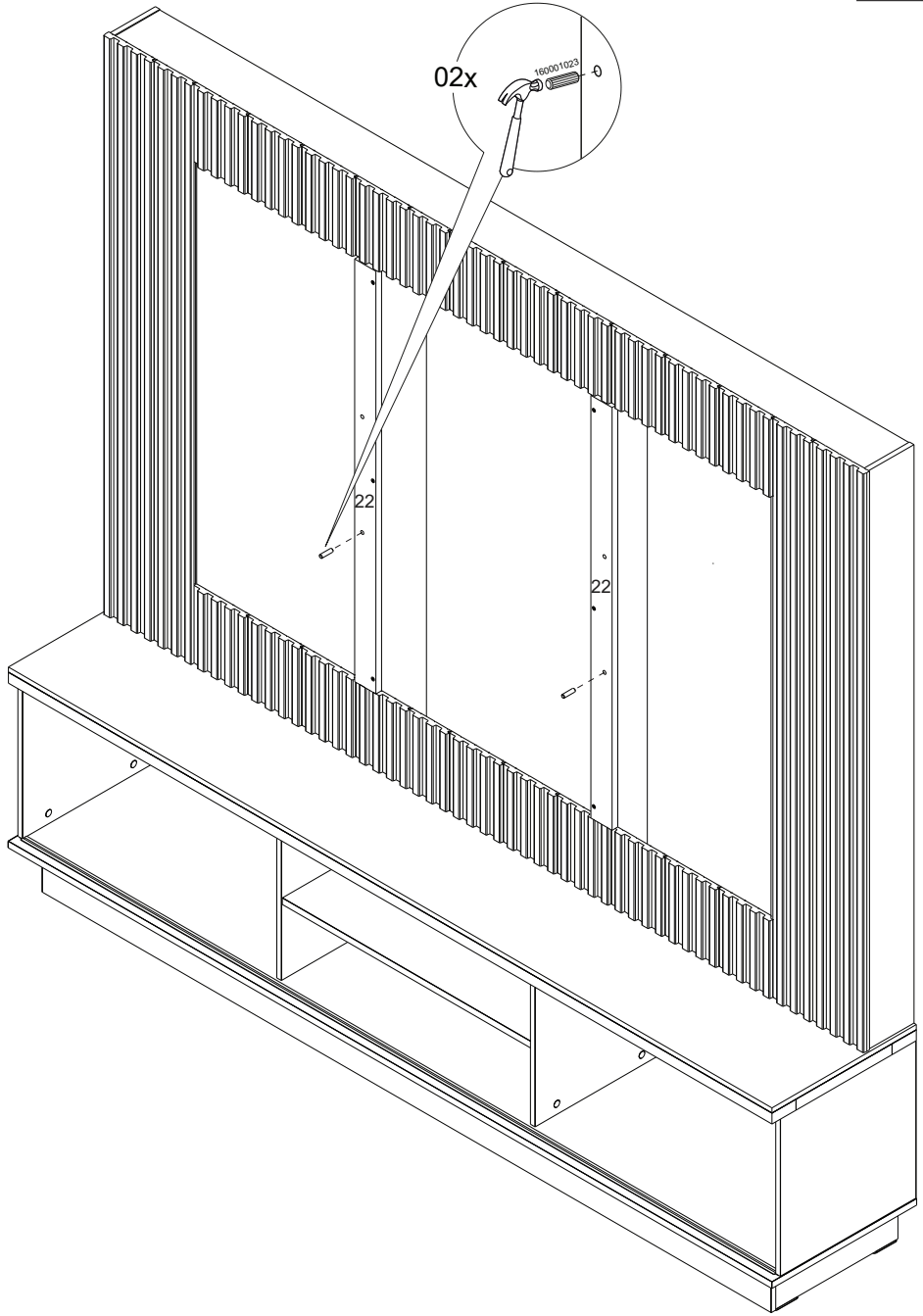
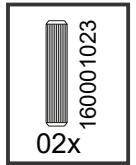

30

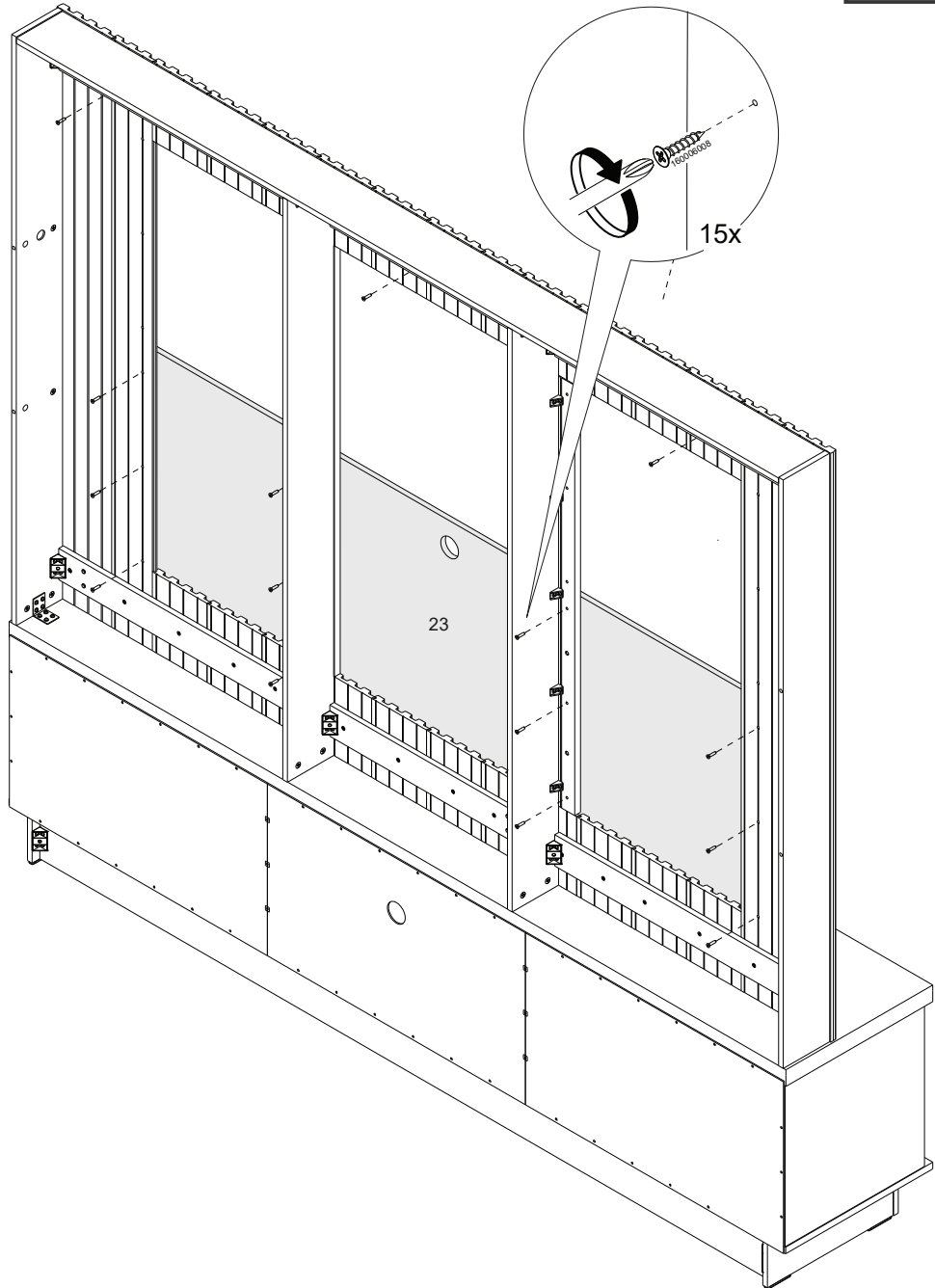
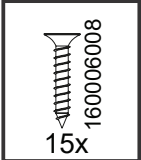

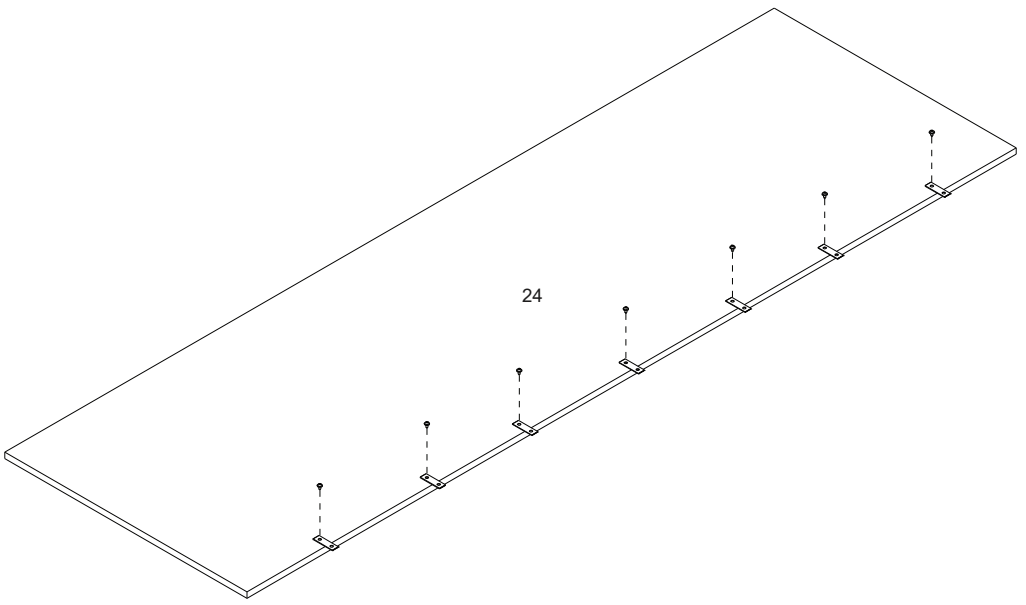
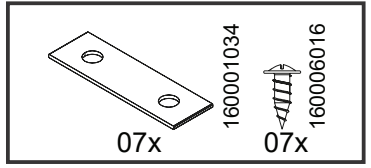

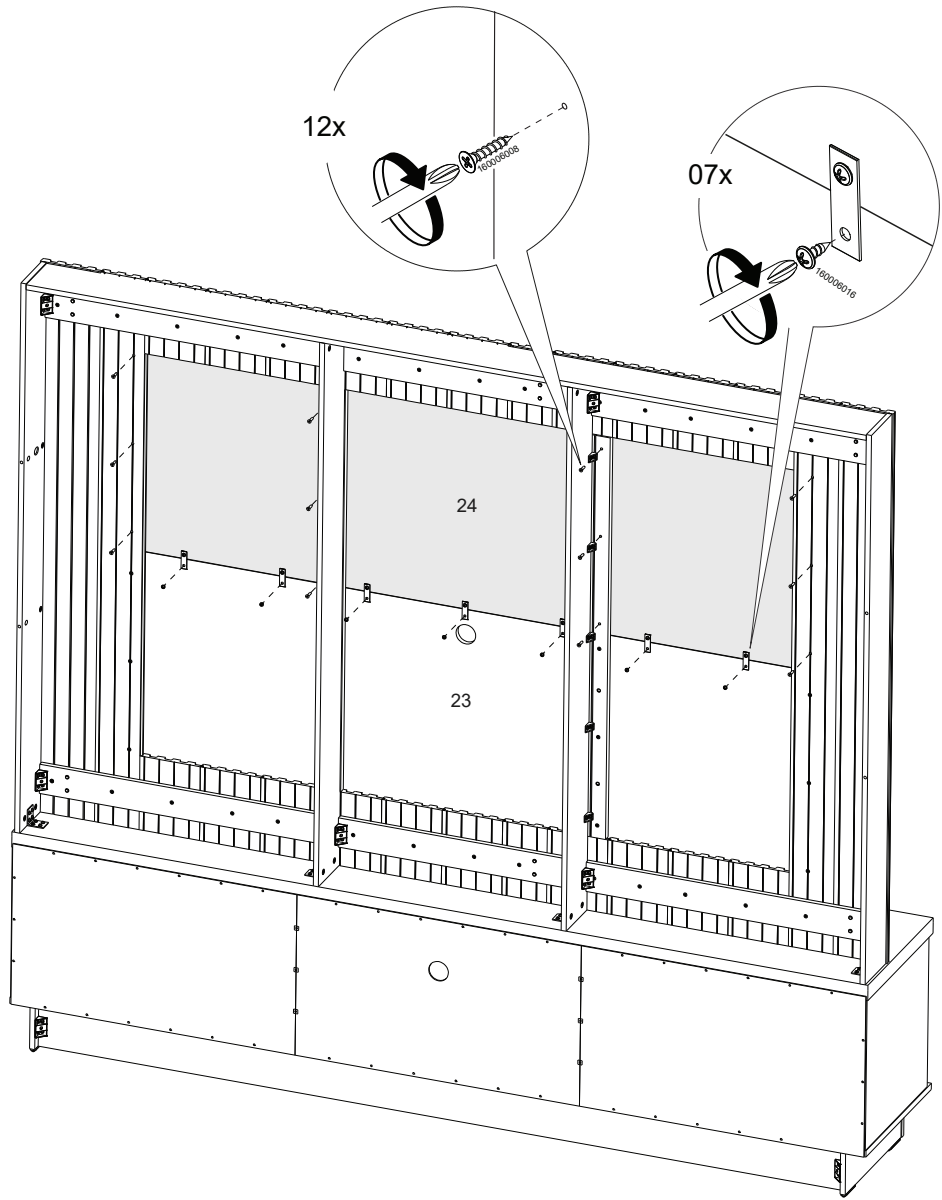
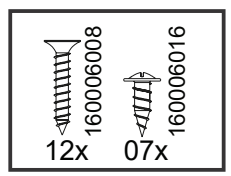



	160002005		160002002
01x		02x	

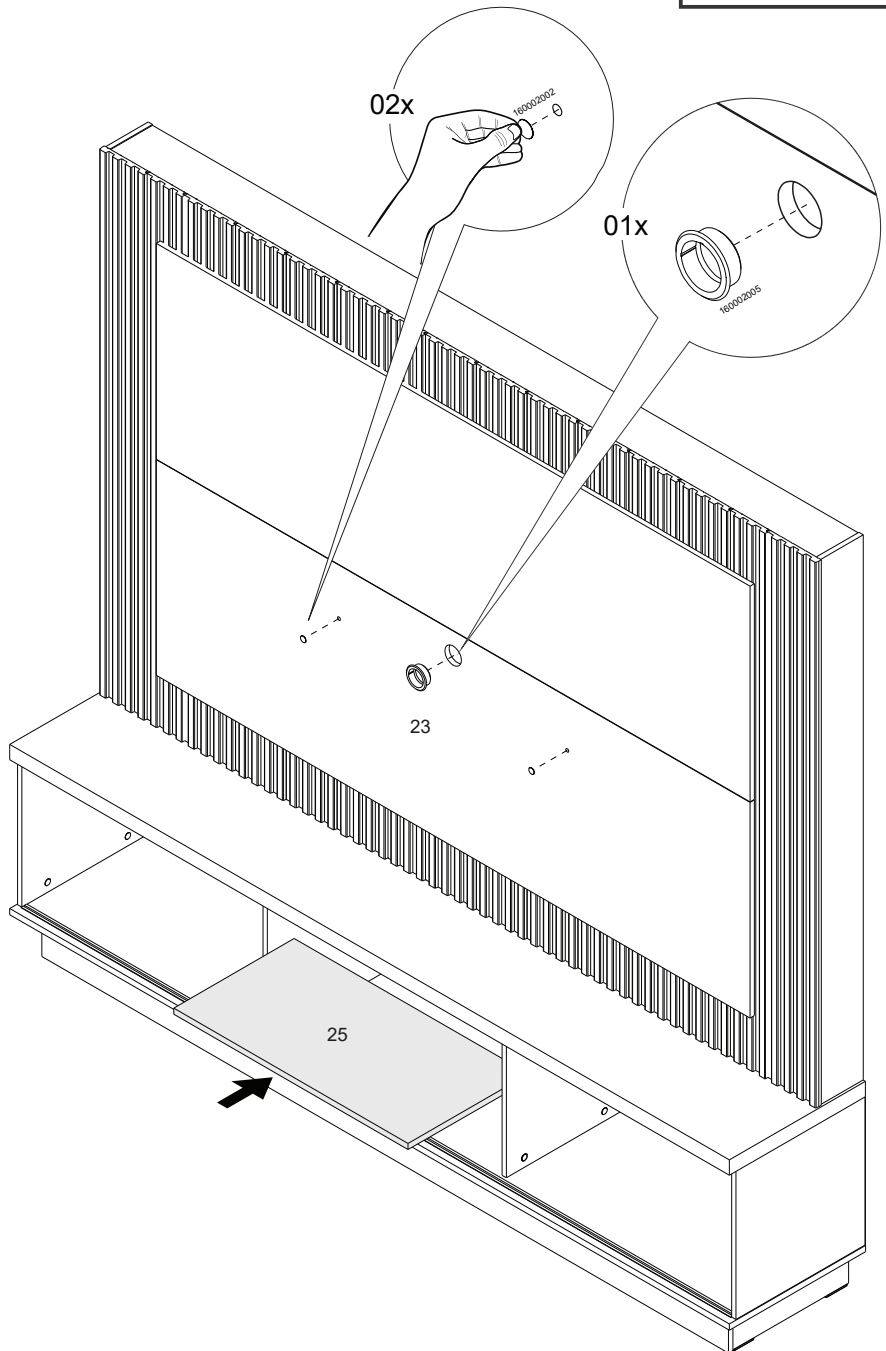

35

- 160006044 02x
- 160005067 02x
- 160002015 04x
- 160003004 04x
- 160003004 04x
- 160003004 16x
- 160003004 02x
- 160006003 02x
- 160002016 02x
- 160002016 02x

