

Linea Brasil

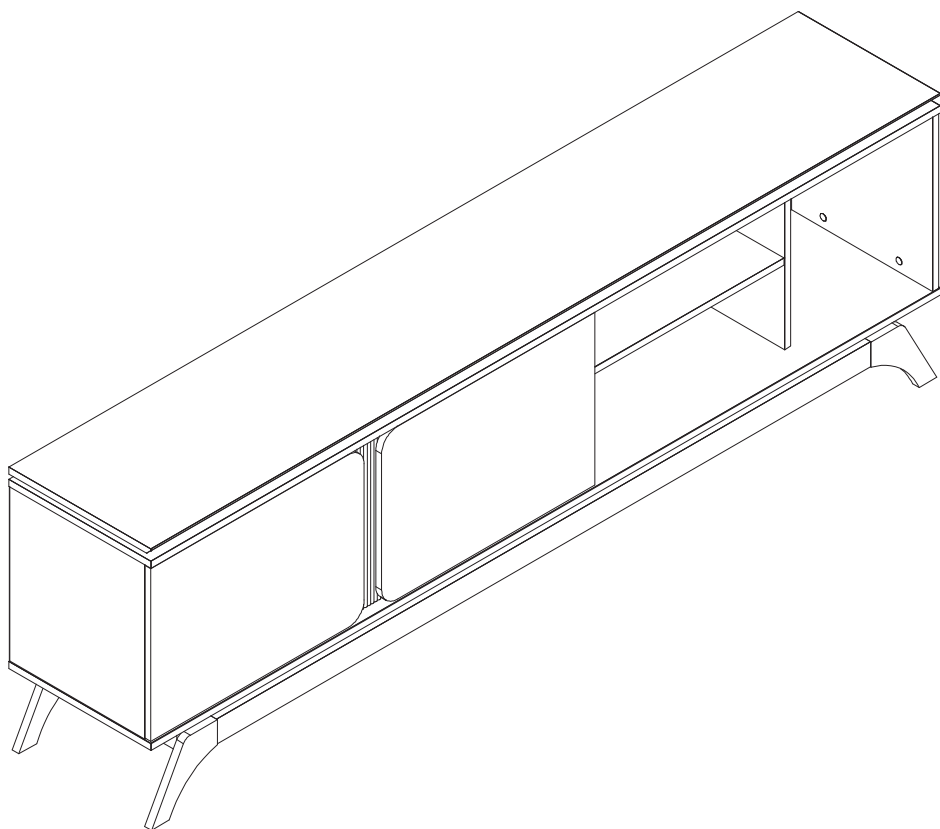

RACK ISTAMBUL

V-5 24/10/25

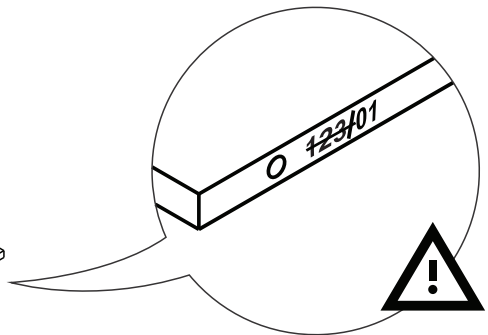
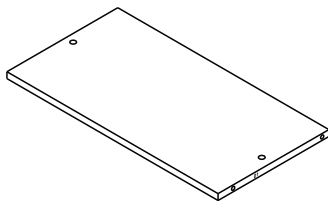
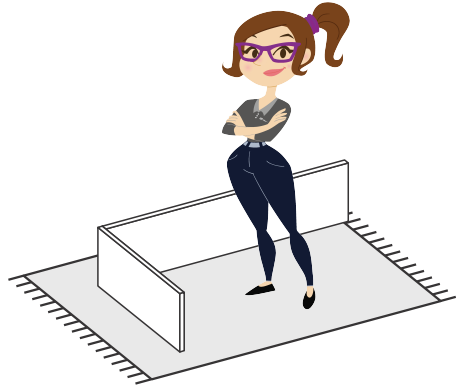
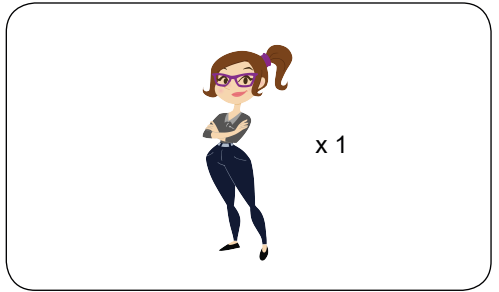
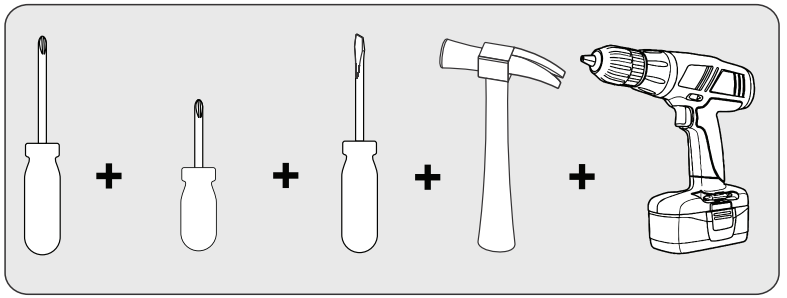
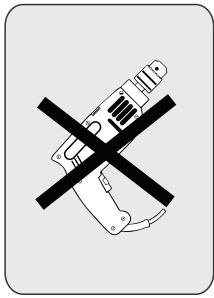

Nossos produtos são garantidos por 90 dias contra defeitos de fabricação. Ao constatar um problema coberto pela garantia, entre em contato com a loja onde o produto foi comprado. Ela estará capacitada para atendê-lo da melhor forma diante de cada caso. Reclamações de garantia somente poderão ser atendidas se o termo de garantia for apresentado no ato de reivindicação, acompanhado de sua nota fiscal de compra.

Nuestros productos están garantidos contra defectos de fabricación por 90 días, a partir de la compra. Ao constatar un problema protegido por la garantía, póngase en contacto con la tienda donde se adquirió el producto. Ella estará capacitada para atenderlo de la mejor manera de acuerdo con cada caso.

Our products are guaranteed against manufacturing defects for 90 days from the date of purchase. When you find a problem covered by the warranty, please contact the store where the product was purchased. The store be able to serve you in the best way in each case.

Exclusões

- Desgaste natural ou danos causados por água, maresia, ferrugem, incêndio, calor, cupins e pragas em geral.
- Montagem, manutenção e uso inadequado.
- Não cumprimento das recomendações técnicas do esquema.
- Montagens e desmontagens após a primeira instalação.
- Instalações elétricas e outras afins.

Exclusiones

- *Desgaste natural o daños causados por agua, mares, maresia, incendios, calor, termitas y plagas en general.*
- *Montaje, mantenimiento y uso inadecuado.*
- *No cumplimiento de las recomendaciones técnicas del esquema.*

Exclusions

- *Natural wear or damage caused by water, sea, rust, fire, heat, termites and plagues in general.*
- *Assembly, maintenance and improper use.*
- *Failure to comply with the technical recommendations of the assembly instructions.*

Importante

A Linea Brasil não autoriza nenhuma pessoa, loja ou entidade assumir em seu nome qualquer outra garantia que não conste no certificado. O fabricante reserva-se no direito de efetuar nos produtos eventuais modificações que considerar necessárias, sem prejudicar as características essenciais. Os produtos terão peças de assistência para reposição no período de 1 ano a contar de sua retirada do mercado, desde que haja matéria-prima equivalente, observando o dispositivo no Art.32 da Lei 8.078/90 (Cód. Defesa do Consumidor). O atendimento para produtos fora de linha é feito por programação especial, através da loja revendedora sob aprovação de consulta prévia ao fabricante.

Importante

Linea Brasil no autoriza a ninguna persona, tienda o entidad a asumir en su nombre cualquier otra garantía que no figure en el certificado. El fabricante se reserva el derecho de efectuar en los productos eventuales modificaciones que considere necesarias, sin perjudicar las características esenciales. Los productos tendrán piezas de asistencia para reposición en el período de 1 año a partir de su retirada del mercado. La atención para productos fuera de línea es hecha por programación especial, a través de la tienda revendedora bajo aprobación de consulta previa al fabricante.

Important

Linea Brasil does not authorize any person, store or entity to assume on its behalf any other warranty that does not appear on the certificate. The manufacturer reserves the right to make in the products any modifications that it considers necessary without prejudice to the essential characteristics. The products will have replacement parts within one year of being withdrawn from the market. The service for off-line products is done by special programming, through the store reseller under prior consultation with the manufacturer.

INSTRUÇÕES DE LIMPEZA E CONSERVAÇÃO

INSTRUCCIONES PARA LA LIMPIEZA E CONSERVACION / CLEAN AND PRESERVATION INSTRUCTURE

Para retirar o pó, utilize um pano seco, espanador ou aspirador. Se necessário, para uma limpeza mais efetiva, utilize um pano levemente umedecido com água. Finalize com uma flanela limpa e seca.

Para eliminar el polvo, utilice un paño seco, mopa o la aspiradora. Si es necesario, para una limpieza más eficaz, utilice un paño ligeramente humedecido con agua. Terminar con un paño limpio y seco.

To take dirty, use a dry cloth, duster or vacuum. If necessary to take the dust, use a wet cloth. Finish with a clean and dry flannel.

IMPORTANTE / IMPORTANTE / IMPORTANT

 Não utilize produtos abrasivos como álcool e detergentes, como também esponjas rígidas ou palha de aço na limpeza dos móveis. *No use limpiadores abrasivos como alcohol y detergentes, así como esponjas rígidas o lana de acero para limpiar los muebles. Do not use abrasives such as alcohol and detergent, tough soaker also steel wool to clean the furniture.*

 Proteja a superfície do móvel de objetos que transmitam calor ou umidade. *Proteja la superficie del mueble de objetos que transmitan calor o humedad. Protect the surface of the furniture against objects that can pass heat and humidity.*

 Evitar o contato de água e produto de limpeza com o rodapé do produto, pois poderá danificá-lo. *Evitar el contacto con agua y producto de limpieza con el rodapé del producto, pues podrá dañarlo. Avoid the contact of water and cleaning products with baseboard, cause it should damage your product.*

 Procure sempre utilizar flanela limpa e seca para a limpeza. *Busque siempre utilizar flanela limpia y seca para la limpieza. Try always to use a clean and dry flannel to cleaning.*

 Cuidado com objetos pontiagudos, eles podem arranhar a superfície das portas e tampo. *Cuidado con objetos afilados, ellos pueden rayar la superficie de las puertas e la tapa. Take care with sharp objects, they can scratch the door lid surface.*

Imagem Ilustrativa/ Illustrative Image/ Imagen Ilustrativa

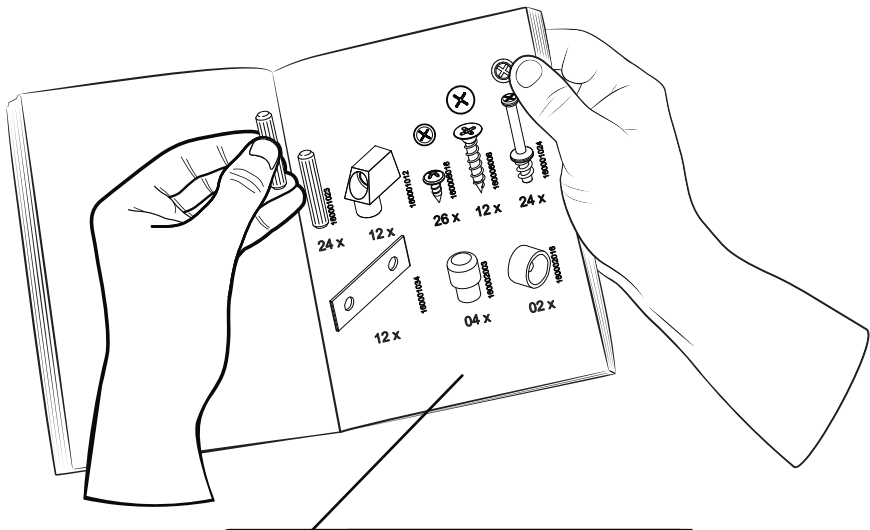

Preste Atenção! ¡Preste atención! Attention!



As ferragens dos nossos manuais são sempre apresentadas nas mesmas proporções da peça na vida real.
Caso apareça alguma dúvida no decorrer do processo de montagem, coloque a ferragem ao lado do desenho e faça a consulta :D

Los accesorios de nuestros manuales siempre se presentan en las mismas proporciones que la pieza en la vida real.
Si tiene alguna duda durante el proceso de montaje, coloque los accesorios junto al dibujo y haga una consulta :D

The accessories in our manuals are always presented in the same proportions as the spare part in real life.
If you have any questions during the assembly process, place the accessory next to the drawing and make an inquiry :D

Símbolos: Símbolos: Symbols:



- + Parafuso Phillips
- Parafuso Fenda
- ⊗ Parafuso Allen

- + Tomillo Phillips
- Tomillo Ranurado
- ⊗ Tomillo Allen

- + Phillips screw
- Slotted Screw
- ⊗ Allenscrew

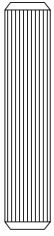

160001023

36x

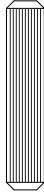

160001059

08x

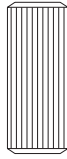

160001003

06x



160001024

22x

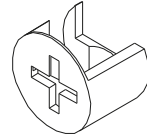

160001025

22x

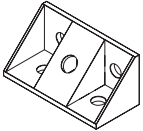

160001018

15x



160001032

05x



160001011

06x

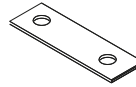

160001034

02x

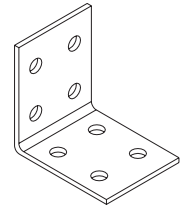

160001035

02x

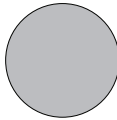

160002002

20x



160002012

02x



160002015

04x

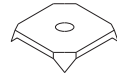

160001002

08x

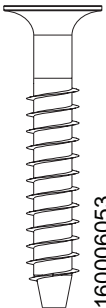

160006053

01x



160006055

26x

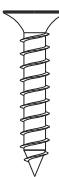

160006018

16x
1:1



160006016

130x



160006011

61x

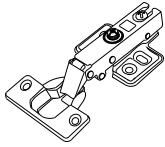

160003014

04x

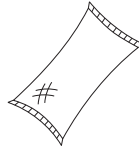

160001001

01x

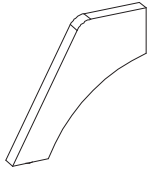

160009057

04x

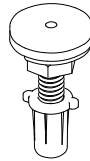

160009049

01x

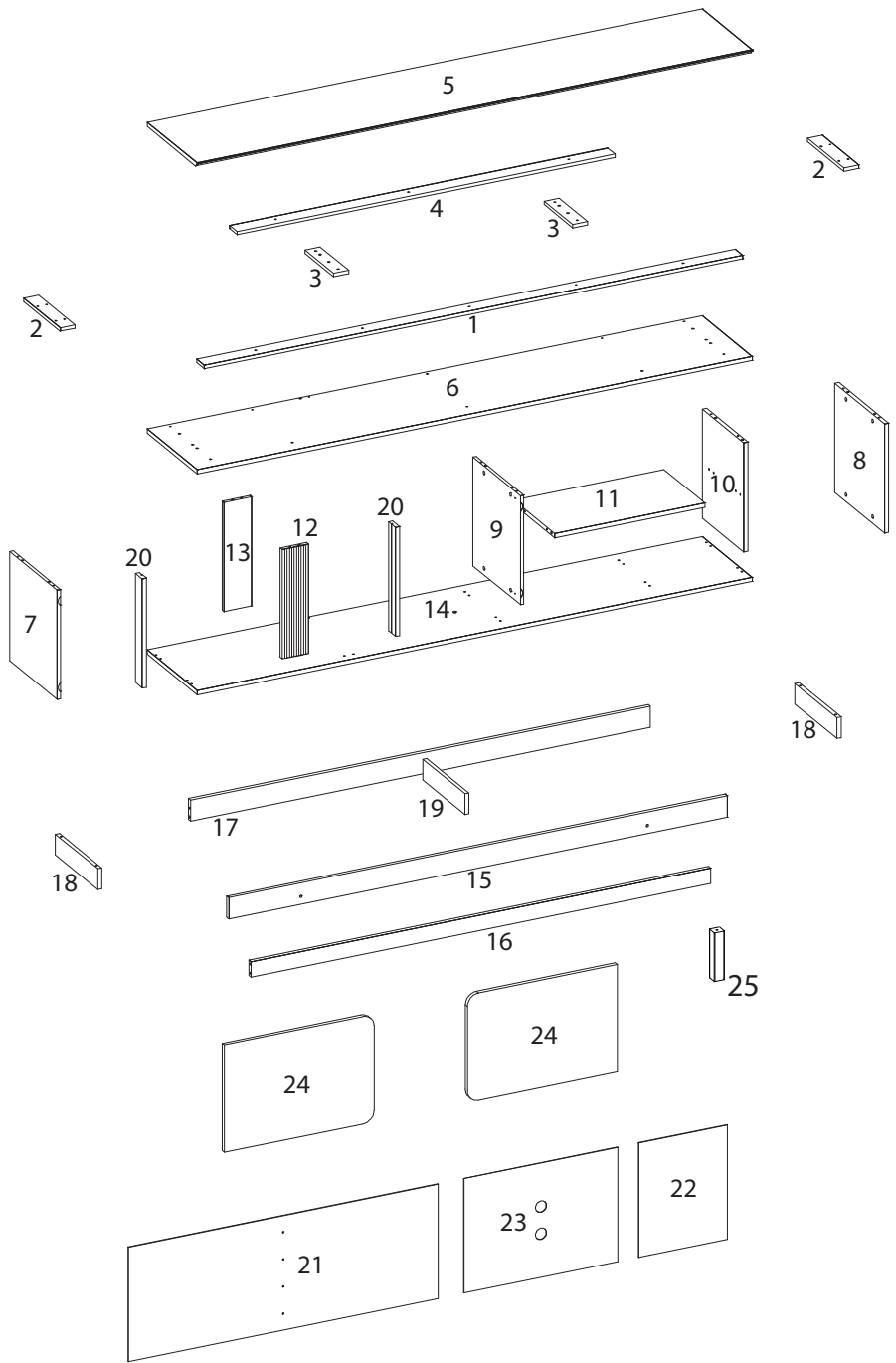

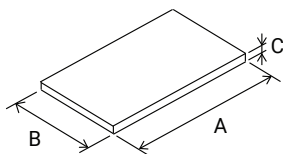

VOLUME	ITEM	PEÇA	DESCRIÇÃO	DIMENSÕES (mm)			QUANTIDADE	Material
				Dimensión/Dimension				
				A	B	C		
Caja BOX	Artículo Item	Pieza Part	Descripción Description				Cantidad Amount	
1	1	510417001	ENGROSSO FRONTAL	1940	54	12	1	MDP
1	2	510417002	ENGROSSO LATERAL	262	54	12	2	MDP
1	3	510417003	ENGROSSO CENTRAL	206	54	12	2	MDP
1	4	510417004	ENGROSSO TRASEIRO	1362	54	12	1	MDP
1	5	510417005	TAMPO SUPERIOR	2000	360	15	1	MDP
1	6	510417006	TAMPO INFERIOR	2000	360	15	1	MDP
1	7	510417007	LATERAL ESQUERDA	385	342	12	1	MDP
1	8	510417008	LATERAL DIREITA	385	358	15	1	MDP
1	9	510417009	DIVISAO ESQUERDA	385	342	12	1	MDP
1	10	510417010	DIVISAO DIREITA	385	342	15	1	MDP
1	11	510417011	PRATELEIRA	541	333	15	1	MDP
1	12	510417012	BATENTE FRONTAL	385	96	15	1	MDF
1	13	510417013	BATENTE TRASEIRO	385	100	12	1	MDF
1	14	510417014	BASE	2000	360	15	1	MDP
1	15	510417015	RODAPE FRONTAL	1796	75	15	1	MDP
1	16	160009077	ENCABECAMENTO FRONTAL	1656	55	15	1	MDF
1	17	510417017	RODAPE TRASEIRO	1656	75	15	1	MDP
1	18	510417018	RODAPE LATERAL	304	73	15	2	MDP
1	19	510417019	RODAPE CENTRAL	304	73	15	1	MDP
1	20	510417020	ENCABECAMENTO BATENTE	385	50	15	2	MDP
1	21	510417021	FUNDO ESQUERDO (COM FURO)	1116	414	2.8	1	MDF
1	22	510417022	FUNDO DIREITO	414	320	2.8	1	MDF
1	23	510417023	FUNDO CENTRAL (COM FURO)	554	414	2.8	1	MDF
1	24	510417024	PORTA	540	379	15	2	MDF
1	25	510417028	PE RETANGULAR REGULAVEL	167	40	40	1	MDF

ITEM	DESCRIPTION
1	FRONT THICKNESS
2	SIDE THICKENING
3	CENTRAL THICKNESS
4	BACK THICKNESS
5	TOP TOP
6	LOWER TOP
7	LEFT SIDE
8	RIGHT SIDE
9	LEFT DIVISION
10	RIGHT DIVISION
11	SHELF
12	FRONT STOP
13	REAR STOP
14	BASIS
15	FRONT FOOTING
16	FRONT HEADING
17	REAR FOOTER
18	SIDE FOOTING
19	CENTRAL FOOTING
20	STOP HEADING
21	LEFT BOTTOM (WITH HOLE)
22	RIGHT BACKGROUND
23	CENTRAL BOTTOM (WITH HOLE)
24	DOOR
25	ADJUSTABLE RECTANGULAR FOOT

ARTÍCULO	DESCRIPCIÓN
1	GROSOR DELANTERO
2	ESPOSOR LATERAL
3	ESPOSOR CENTRAL
4	GROSOR DE ESPALDA
5	ARRIBA ARRIBA
6	SUPERIOR INFERIOR
7	LADO IZQUIERDO
8	LADO DERECHO
9	DIVISIÓN IZQUIERDA
10	DIVISIÓN DERECHA
11	ESTANTE
12	PARADA DELANTERA
13	PARADA TRASERA
14	BASE
15	PIE DELANTERA
16	TÍTULO DELANTERO
17	PIE TRASERO
18	PIE LATERAL
19	PIE CENTRAL
20	DEJAR DE RUMBO
21	FONDO IZQUIERDO (CON AGUJERO)
22	ANTECEDENTES DERECHOS
23	FONDO CENTRAL (CON AGUJERO)
24	PUERTA
25	PIE RECTANGULAR AJUSTABLE

01

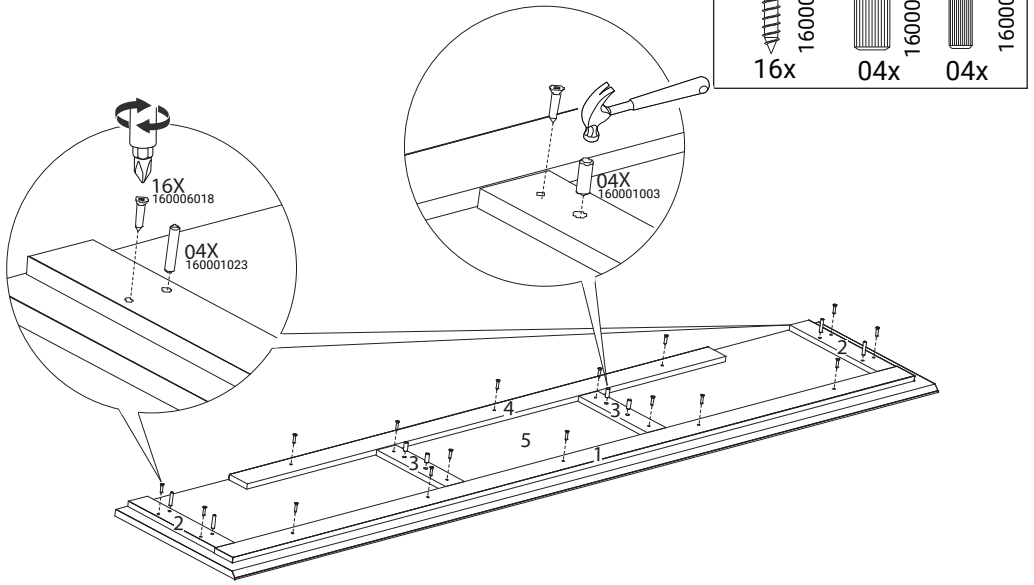

02

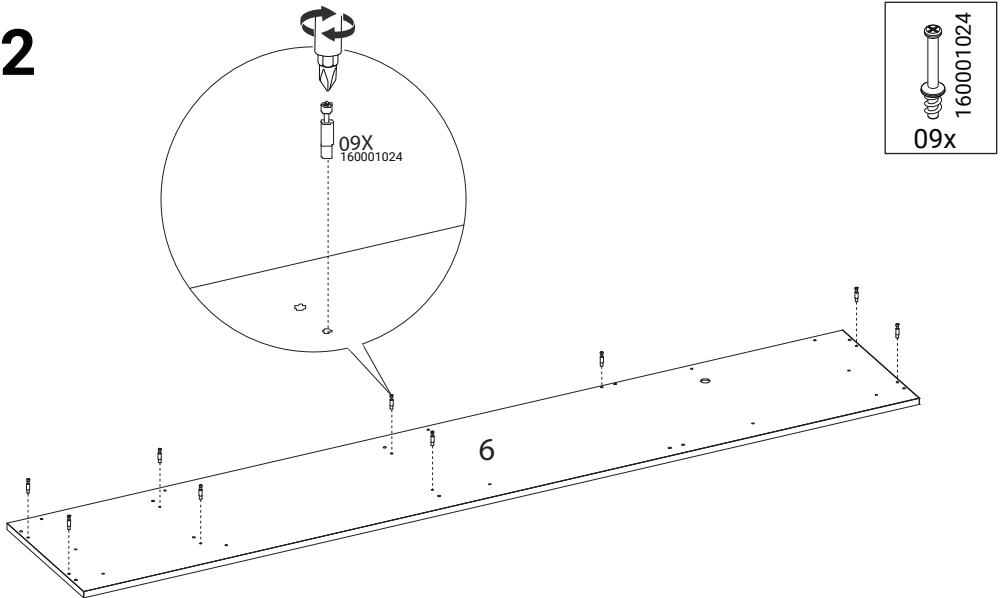

03

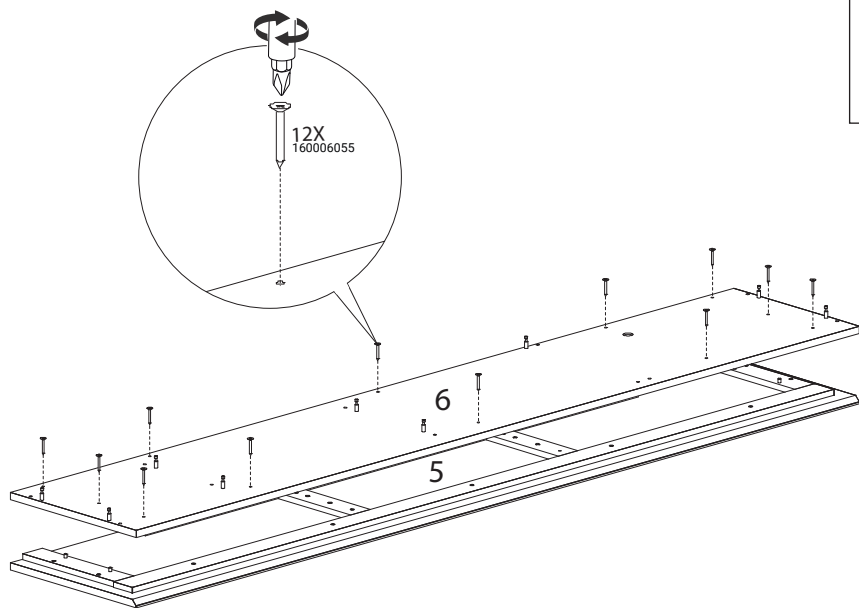

04

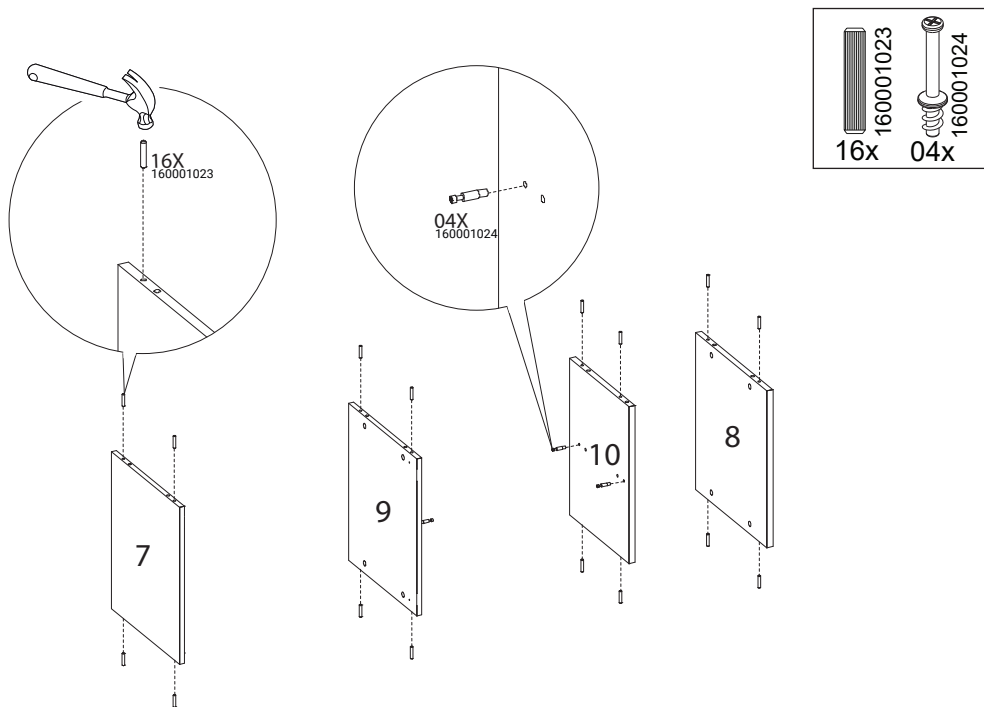

05

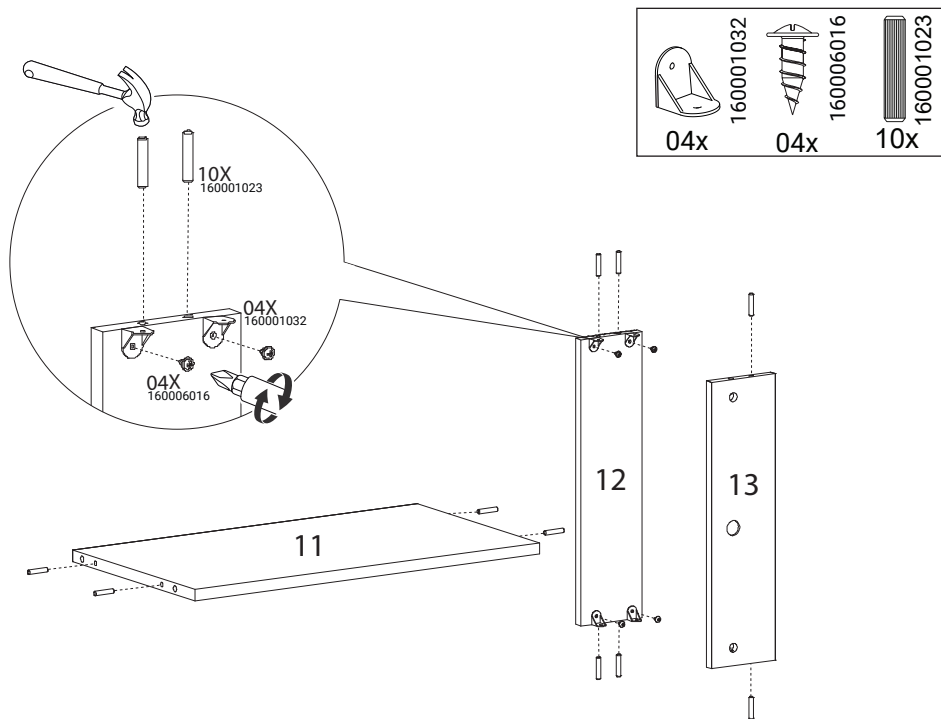

06

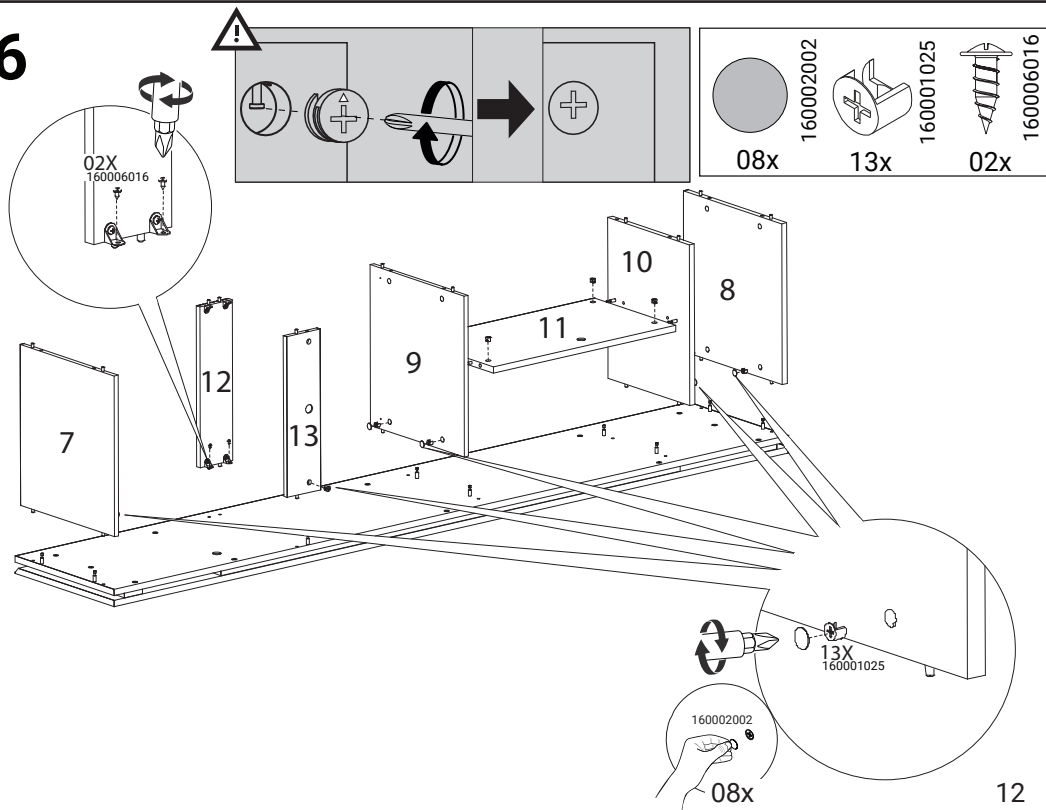

07

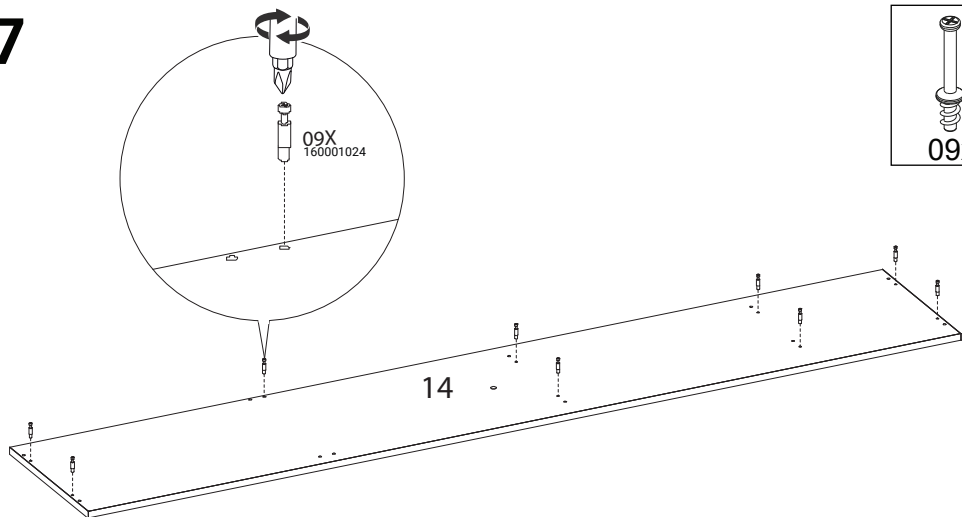

08

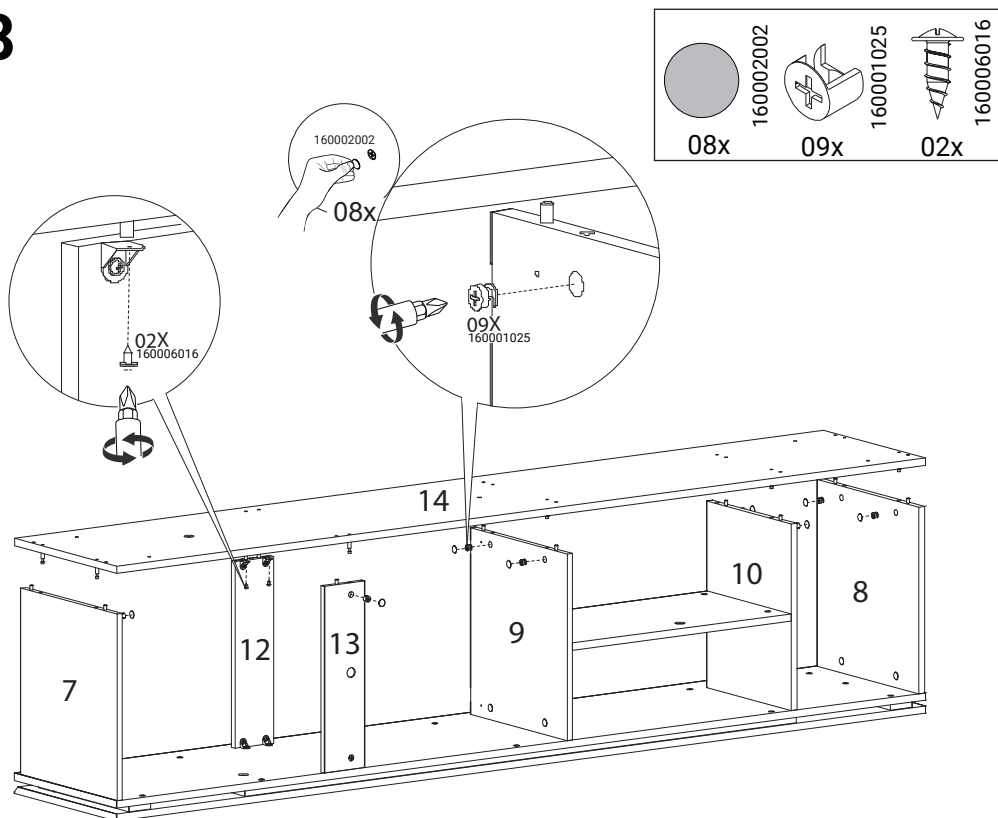



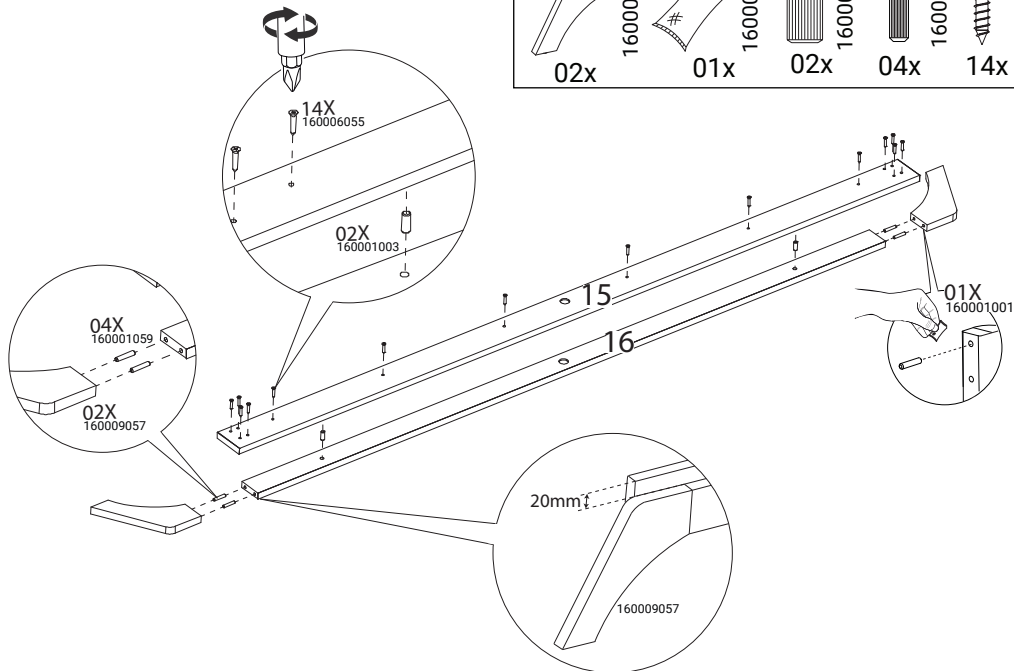
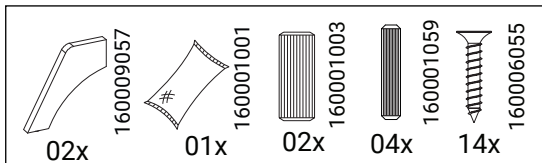



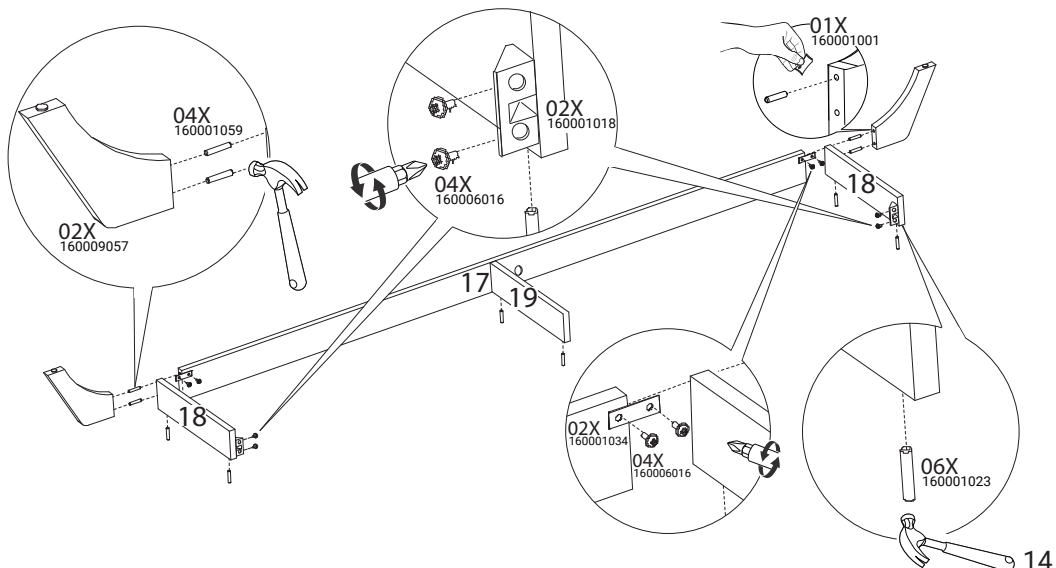
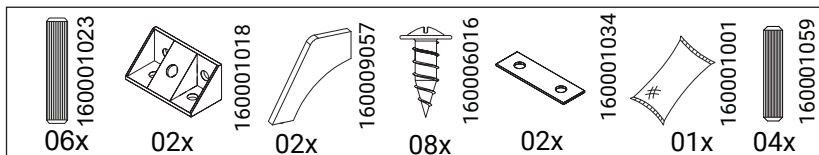

09



10



11

- 
 160009049
 01x
- 
 160001035
 02x
- 
 160002002
 01x
- 
 160006053
 01x
- 
 160001032
 01x
- 
 160001032
 74x
- 
 160006016
 13x
- 
 160001018
 13x

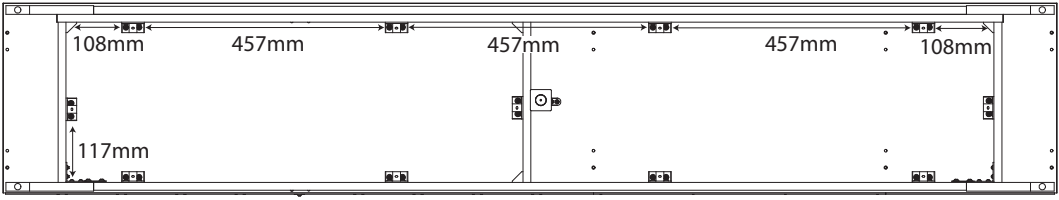
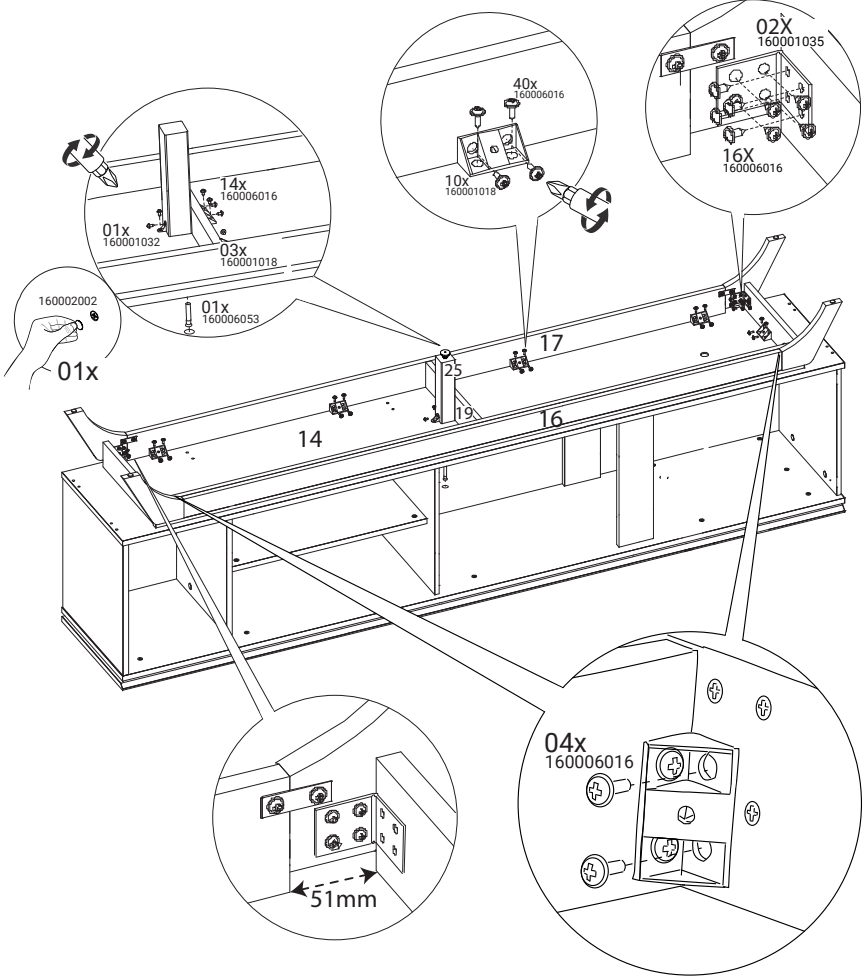
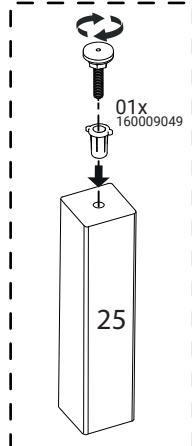

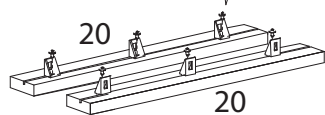
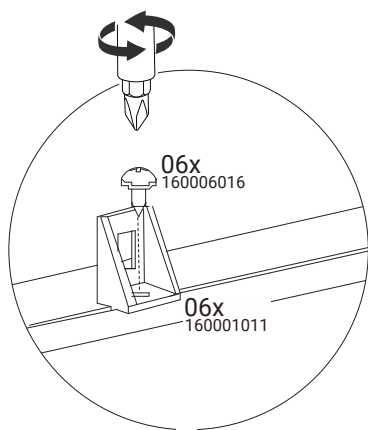
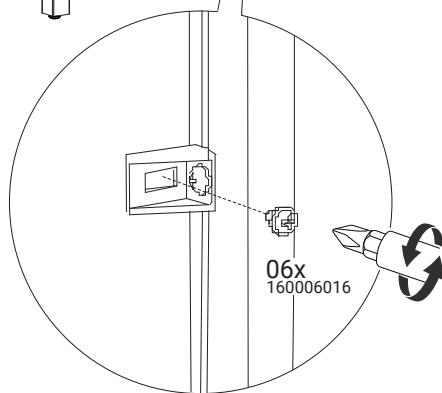
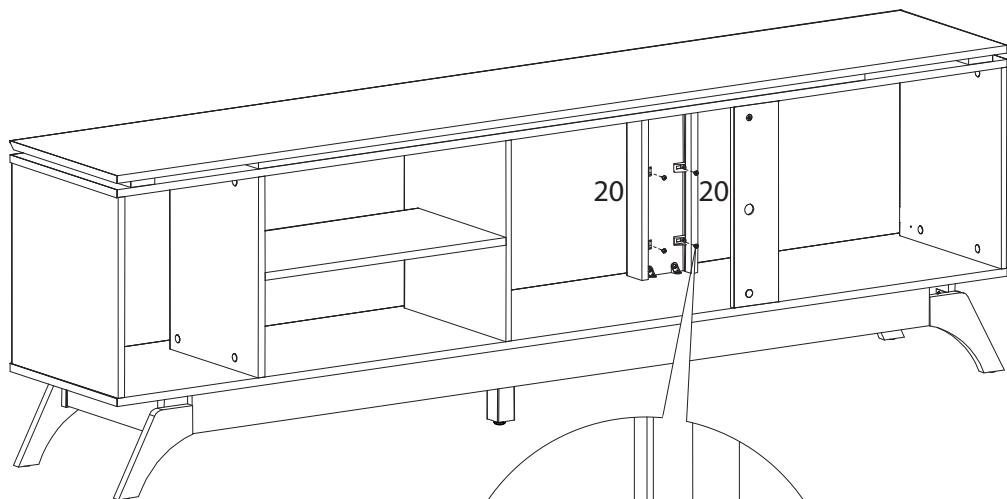
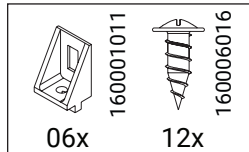

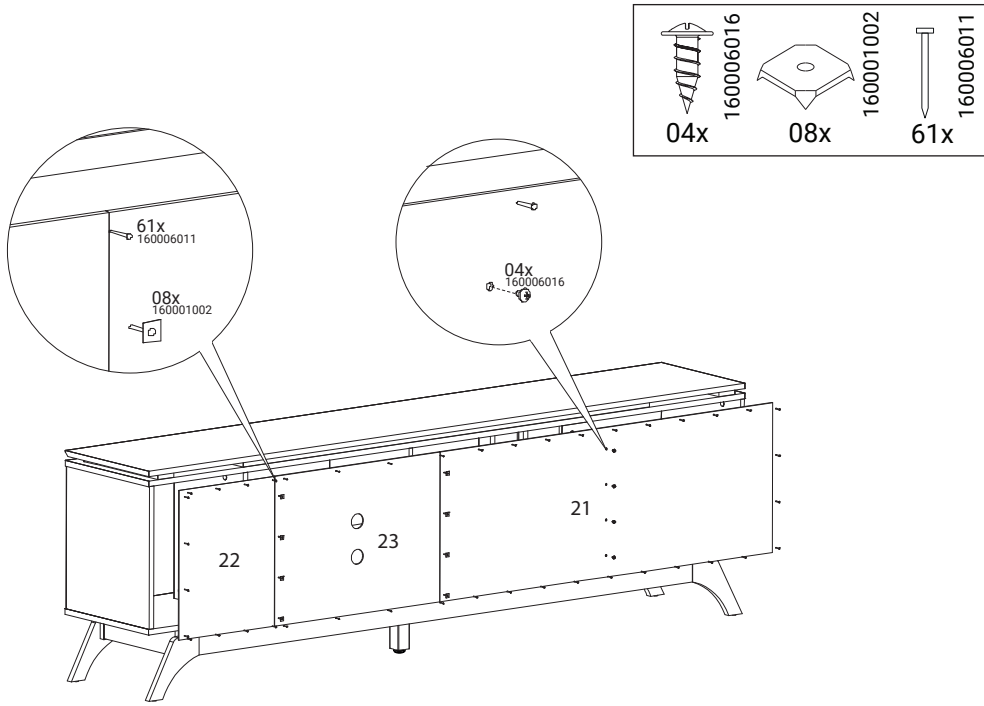

13

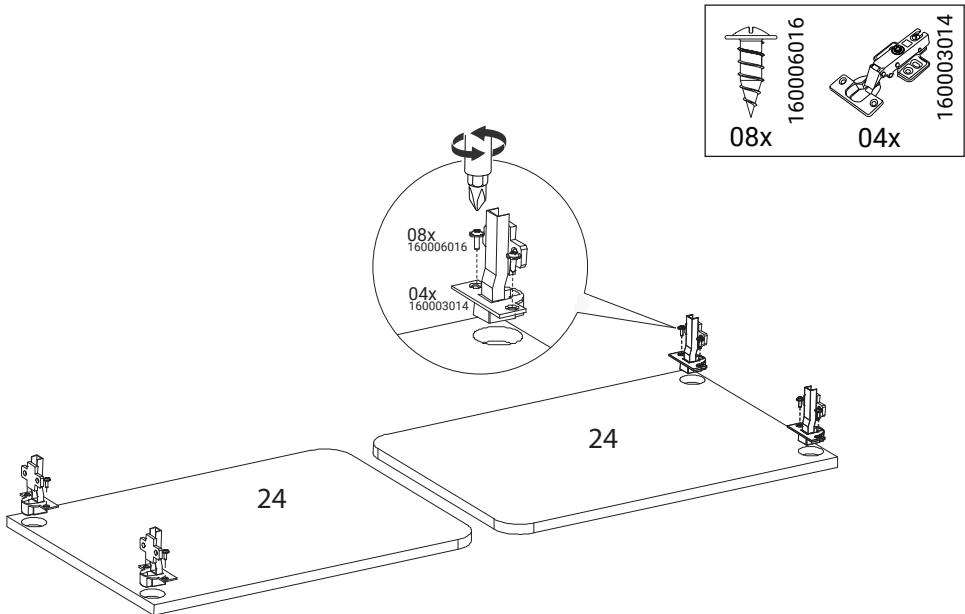

14



15

	160002015		160006016
04x		08x	

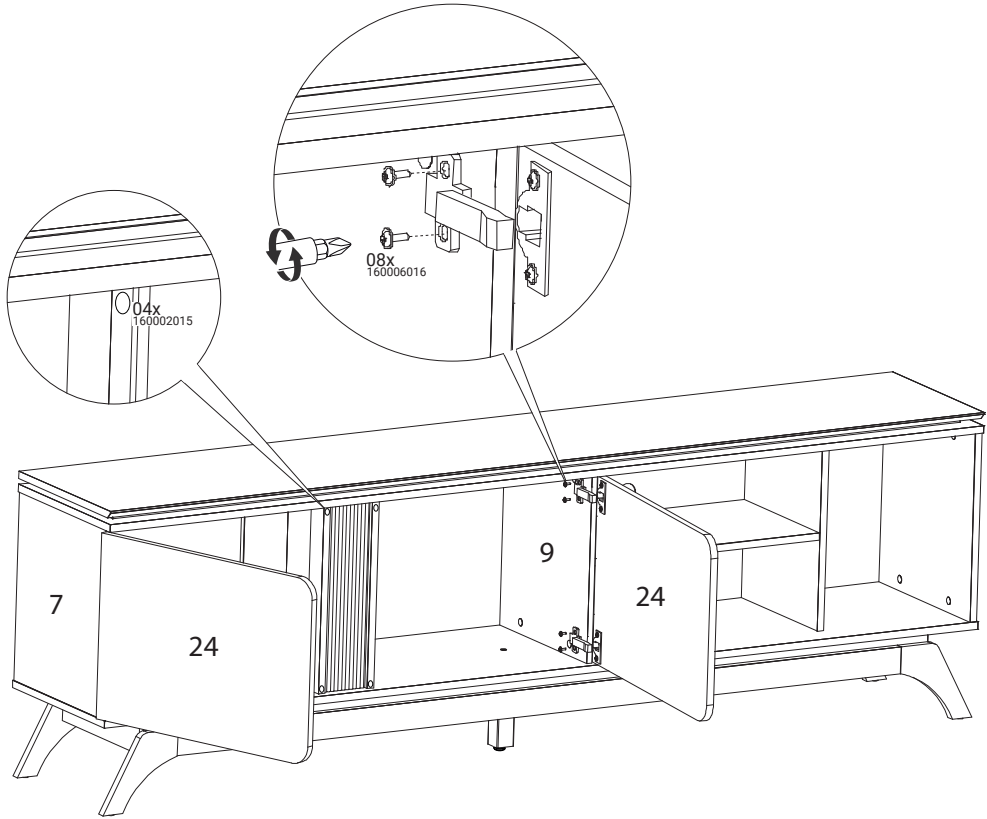

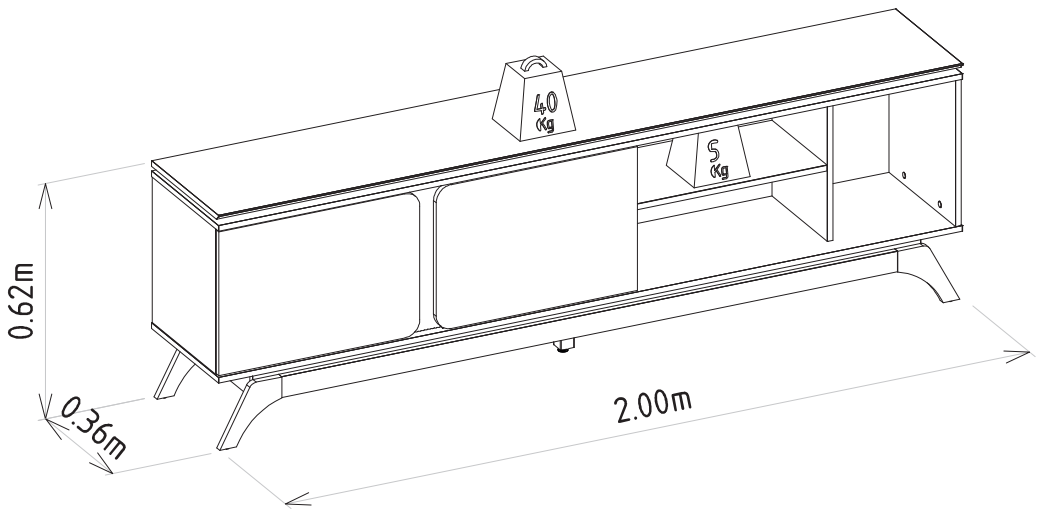

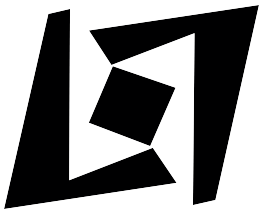

Linea Brasil