

PAINEL OURO PRETO

V-6 10/01/25

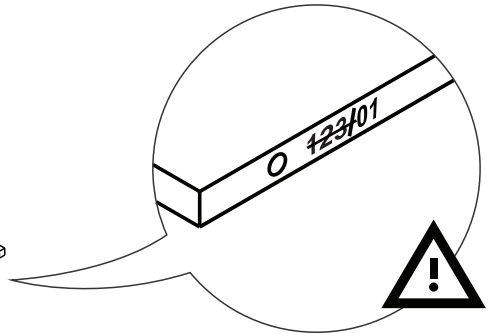
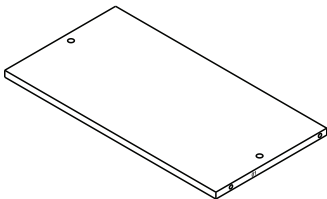
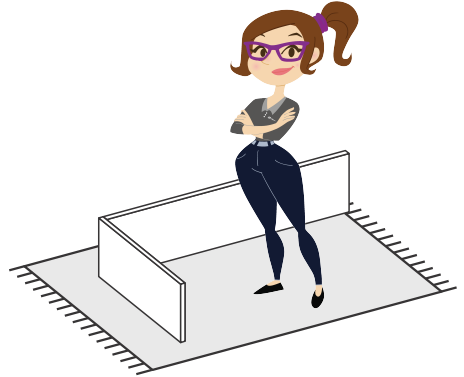
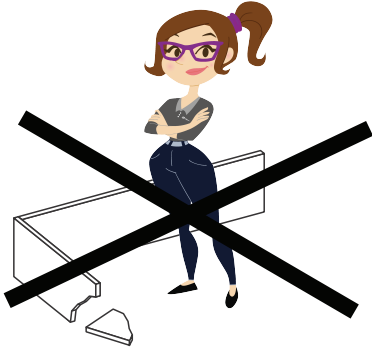
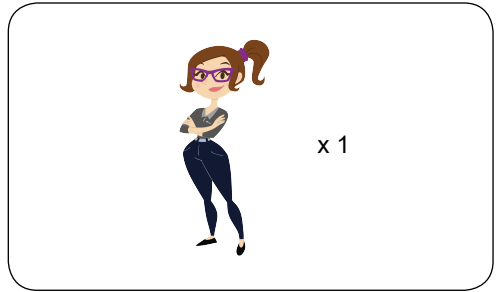
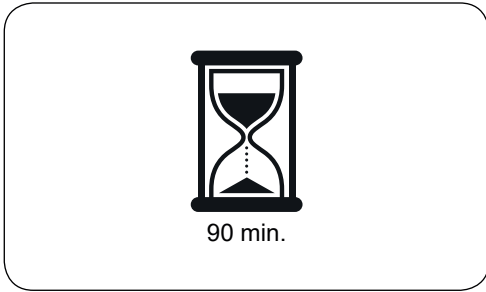
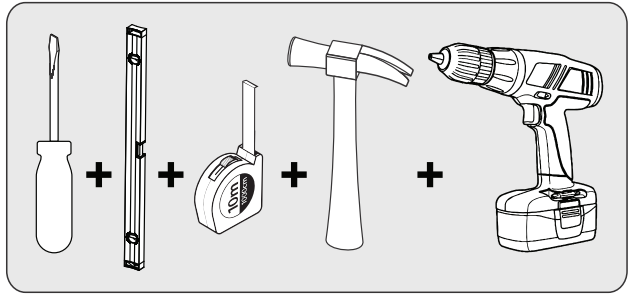
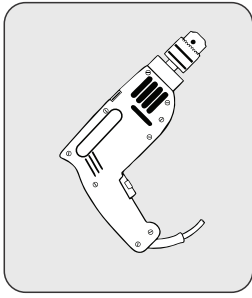

GARANTIA / GARANTIA / WARRANTY

Nossos produtos são garantidos por 90 dias contra defeitos de fabricação. Ao constatar um problema coberto pela garantia, entre em contato com a loja onde o produto foi comprado. Ela estará capacitada para atendê-lo da melhor forma diante de cada caso. Reclamações de garantia somente poderão ser atendidas se o termo de garantia for apresentado no ato de reivindicação, acompanhado de sua nota fiscal de compra.

Nuestros productos están garantidos contra defectos de fabricación por 90 días, a partir de la compra. Ao constatar un problema protegido por la garantía, póngase en contacto con la tienda donde se adquirió el producto. Ella estará capacitada para atenderlo de la mejor manera de acuerdo con cada caso.

Our products are guaranteed against manufacturing defects for 90 days from the date of purchase. When you find a problem covered by the warranty, please contact the store where the product was purchased. The store is able to serve you in the best way in each case.

Exclusões

- Desgaste natural ou danos causados por água, maresia, ferrugem, incêndio, calor, cupins e pragas em geral.
- Montagem, manutenção e uso inadequado.
- Não cumprimento das recomendações técnicas do esquema.
- Montagens e desmontagens após a primeira instalação.
- Instalações elétricas e outras afins.

Exclusiones

- Desgaste natural o daños causados por agua, mares, maresia, incendios, calor, termitas y plagas en general.
- Montaje, mantenimiento y uso inadecuado.
- No cumplimiento de las recomendaciones técnicas del esquema.
- Montaje y desmontaje después de la primera instalación.
- Instalaciones eléctricas y otras afines.

Exclusions

- Natural wear or damage caused by water, sea, rust, fire, heat, termites and plagues in general.
- Assembly, maintenance and improper use.
- Failure to comply with the technical recommendations of the assembly instructions.
- Assembly and disassembly after first installation.

Importante

A Linea Brasil não autoriza nenhuma pessoa, loja ou entidade assumir em seu nome qualquer outra garantia que não conste no certificado. A fabricante reserva-se no direito de efetuar nos produtos eventuais modificações que considerar necessárias, sem prejudicar as características essenciais. Os produtos terão peças de assistência para reposição no período de 1 ano a contar de sua retirada do mercado, desde que haja matéria-prima equivalente, observando o dispositivo no Art.32 da Lei 8.078/90 (Cód. Defesa do Consumidor). O atendimento para produtos fora de linha é feito por programação especial, através da loja revendedora sob aprovação de consulta prévia ao fabricante.

Importante

Linea Brasil no autoriza a ninguna persona, tienda o entidad a asumir en su nombre cualquier otra garantía que no figure en el certificado. El fabricante se reserva el derecho de efectuar en los productos eventuales modificaciones que considere necesarias, sin perjudicar las características esenciales. Los productos tendrán piezas de asistencia para reposición en el período de 1 año a partir de su retirada del mercado. La atención para productos fuera de línea es hecha por programación especial, a través de la tienda revendedora bajo aprobación de consulta previa al fabricante.

Important

Linea Brasil does not authorize any person, store or entity to assume on its behalf any other warranty that does not appear on the certificate. The manufacturer reserves the right to make in the products any modifications that it considers necessary without prejudice to the essential characteristics. The products will have replacement parts within one year of being withdrawn from the market. The service for off-line products is done by special programming, through the store reseller under prior consultation with the manufacturer.

INSTRUÇÕES DE LIMPEZA E CONSERVAÇÃO

INSTRUCCIONES PARA LA LIMPIEZA E CONSERVACION / CLEAN AND PRESERVATION INSTRUCTURE

Para retirar o pó, utilize um pano seco, espanador ou aspirador. Se necessário, para uma limpeza mais efetiva, utilize um pano levemente umedecido com água. Finalize com uma flanela limpa e seca.

Para eliminar el polvo, utilice un paño seco, mopa o la aspiradora. Si es necesario, para una limpieza más eficaz, utilice un paño ligeramente humedecido con agua. Terminar con un paño limpio y seco.

To take dirty, use a dry cloth, duster or vacuum. If necessary to take the dust, use a wet cloth. Finish with a clean and dry flannel.

IMPORTANTE / IMPORTANTE / IMPORTANT



Não utilize produtos abrasivos como álcool e detergentes, como também esponjas rígidas ou palha de aço na limpeza dos móveis.
No use limpadores abrasivos como alcohol e detergentes, así como esponjas rígidas o lana de acero para limpiar los muebles.
Do not use abrasives such as alcohol and detergent, taugh soaker also steel wool to clean the furniture.



Proteja a superfície do móvel de objetos que transmitam calor ou umidade.
Proteja la superficie del mueble de objetos que transmitan calor o humedad.
Protect the surface of the furniture against objects that can pass heat and humidity.



Evitar o contato de água e produto de limpeza com o rodapé do produto, pois poderá danificá-lo.
Evitar el contacto con agua y producto de limpieza con el rodapé del producto, pues poderá dañarlo.
Avoid the contact of water and cleaning products with baseboard, cause it should damage your product.



Procure sempre utilizar flanela limpa e seca para a limpeza.
Busque siempre utilizar franela limpia y seca para la limpieza.
Try always to use a clean and dry flannel to cleaning.



Cuidado com objetos pontiagudos, eles podem arranhar a superfície das portas e tampo.
Cuidado con objetos afilados, ellos pueden rayar la superficie de las puertas e la tapa.
Take care with sharp objects, they can scratch the door lid surface.

INSTRUÇÃO DE INSTALAÇÃO DE TELEVISORES

INSTRUCCIÓN DE INSTALACIÓN DE TELEVISIÓN / TELEVISION INSTALLATION INSTRUCTION

Para o uso do maior televisor indicado recomendamos a instalação da TV no painel do produto.
Para utilizar el televisor más grande indicado, recomendamos la instalación del televisor en el panel del producto.
To use the largest television indicated, we recommend installing the TV on the product panel.

TAMANHO DE TV SUGERIDO

TAMANO DE TELEVISOR SUGERIDO
SUGGESTED TV SIZE

75"

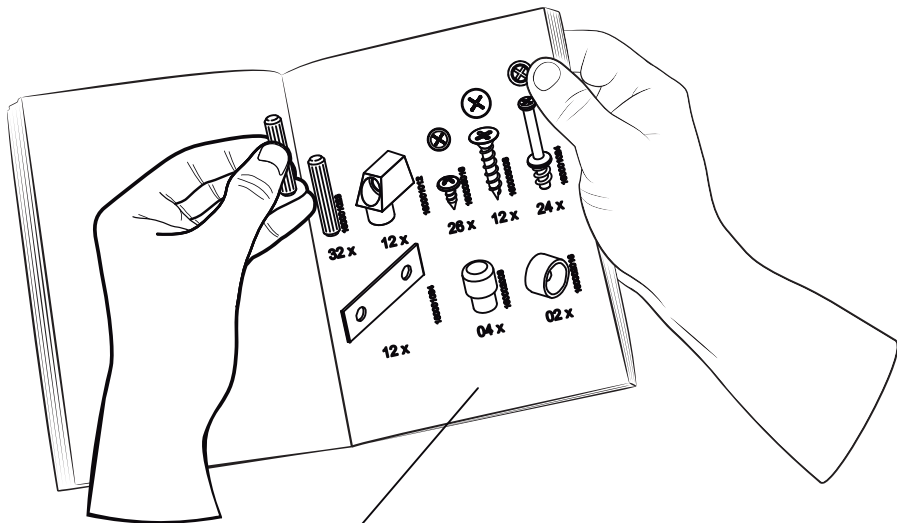

Preste Atenção! ¡Preste atención! Attention!



As ferragens dos nossos manuais são sempre apresentadas nas mesmas proporções de peça na vida real.
Caso apareça alguma dúvida no decorrer do processo de montagem, coloque a ferragem ao lado do desenho e faça a consulta :D

Los accesorios de nuestros manuales siempre se presentan en las mismas proporciones que la pieza en la vida real. Si tiene alguna duda durante el proceso de montaje, coloque los accesorios junto al dibujo y haga una consulta :D

The accessories in our manuals are always presented in the same proportions as the spare part in real life. If you have any questions during the assembly process, place the accessory next to the drawing and make an inquiry :D

Símbolos: Simbolos: Symbols:



+ Parafuso Phillips
- Parafuso Fenda
⬡ Parafuso Allen

+ Tornillo Phillips
- Tornillo Ranurado
⬡ Tornillo Allen

+ Phillips screw
- Slotted Screw
⬡ Allen screw

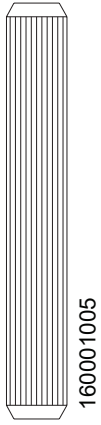

160001005

02 x

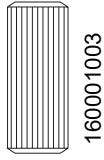

160001003

11 x

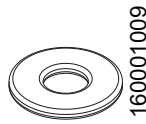

160001009

05 x

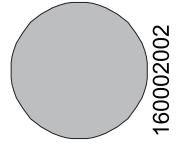

160002002

01x

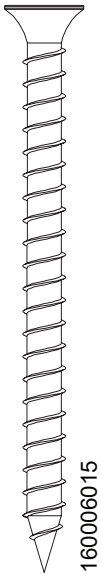

160006015

05 x

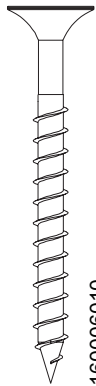

160006010

07 x

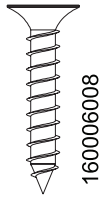

160006008

81 x

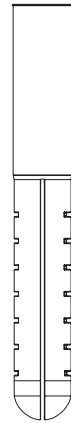

160002006

05 x

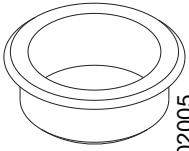

01 x

16002005

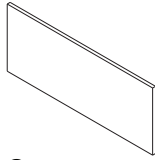

08 x

16001055



01 x

160010022

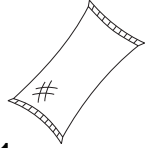

01 x

160001001

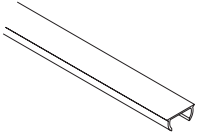

01 x

160011077

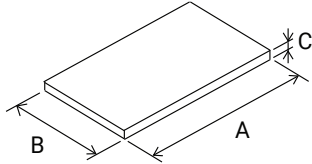

VOLUME Caja Box	ITEM Artículo Item	PEÇA Pieza Part	DESCRIÇÃO Descripción Description	DIMENSÕES (mm) Dimensión/Dimension			QUANTIDADE Cantidad Amount	MATERIAL
				A	B	C		
1	1	510273001	MOLDURA LATERAL ESQUERDA	1484	126	15	1	MDF
1	2	510273002	MOLDURA CENTRAL	1484	147	15	10	MDF
1	3	510273003	MOLDURA CENTRAL (COM FURO)	1484	110	15	1	MDF
1	4	510273004	MOLDURA LATERAL DIREITA	1484	147	15	1	MDF
1	5	510273005	TRAVESSA CENTRAL	1665	70	15	1	MDP
1	6	510273006	TRAVESSA INFERIOR	830	70	15	2	MDP
1	7	510273007	TRAVESSA LATERAL	1480	54	15	2	MDP
1	8	510273008	PRATELEIRA SUPERIOR	1700	145	25	1	MDP
1	9	510273009	TRAVESSA SUPERIOR	1665	70	15	1	MDP
1	10	510273010	TRAVESSA PAREDE	1360	70	15	1	MDP

ARTÍCULO	DESCRIPCIÓN
1	MARCO LATERAL IZQUIERDO
2	MARCO CENTRAL
3	MARCO CENTRAL (CON AGUJERO)
4	MARCO LATERAL DERECHO
5	TRAVESAÑO CENTRAL
6	TRAVESAÑO INFERIOR
7	TRAVESAÑO LATERAL
8	REPISA SUPERIOR
9	TRAVESAÑO SUPERIOR
10	TRAVESAÑO DE PARED

ITEM	DESCRIPTION
1	LEFT SIDE FRAME
2	CENTER FRAME
3	CENTER FRAME (WHITH ROLE)
4	RIGHT SIDE FRAME
5	CENTER CROSSBAR
6	LOWER CROSSBAR
7	SIDE CROSSBAR
8	UPPER SHELF
9	TOP CROSSBAR
10	WALL CROSSBAR

1

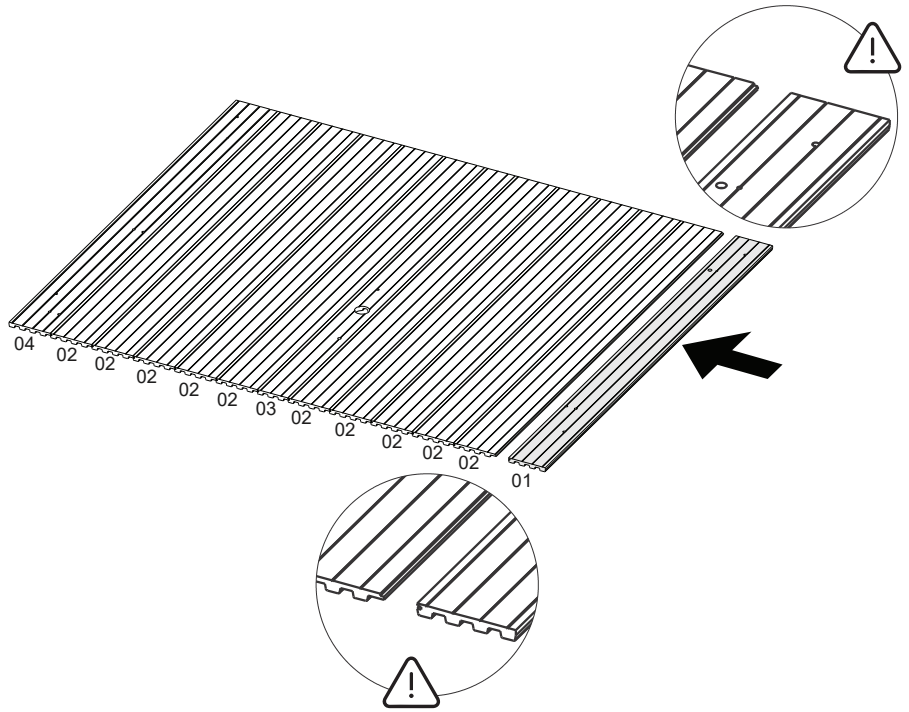

2

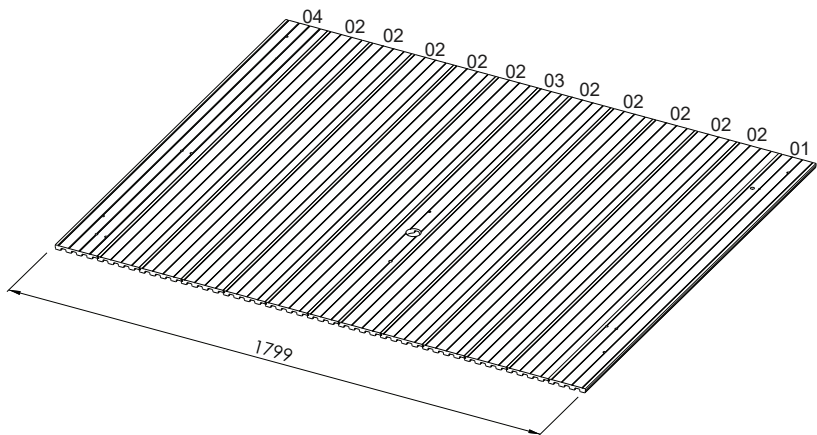
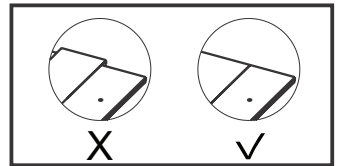

5

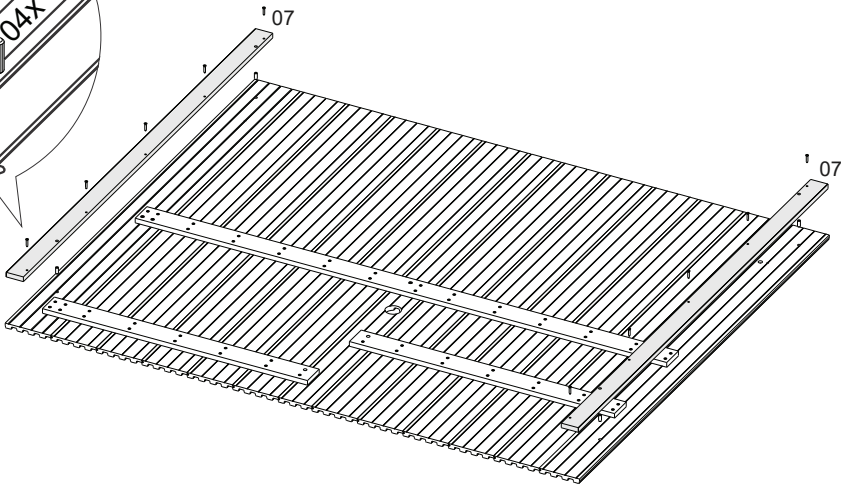
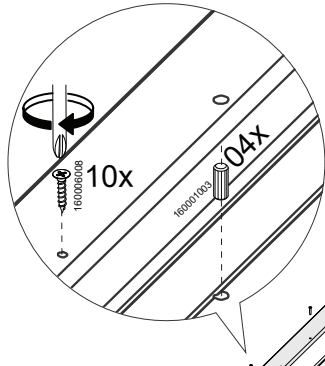
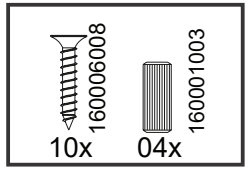

6

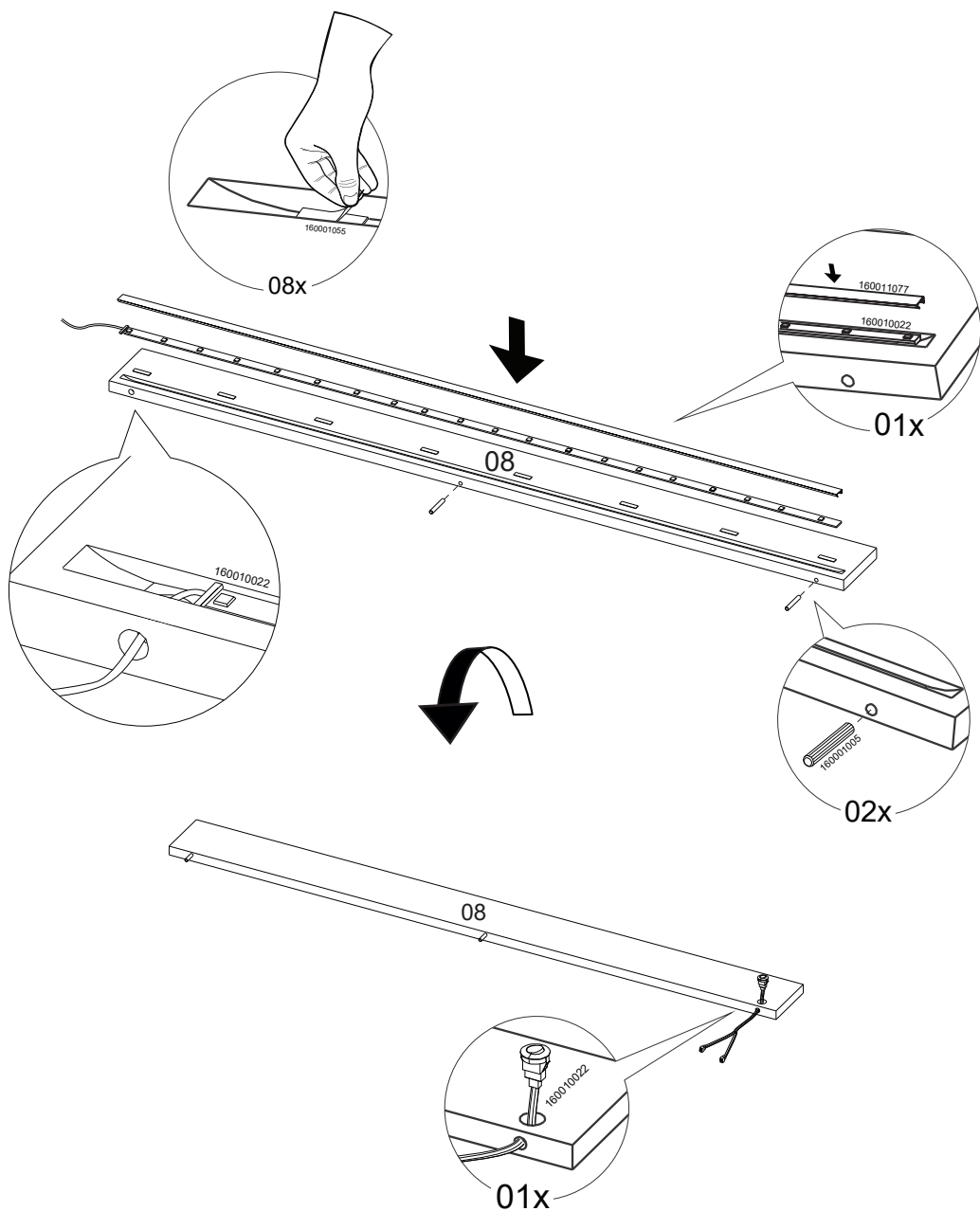
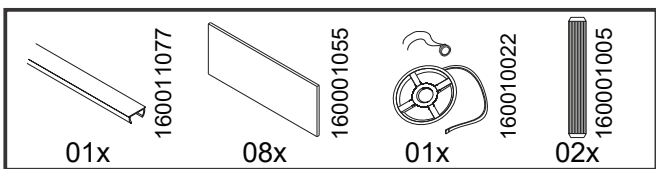

7

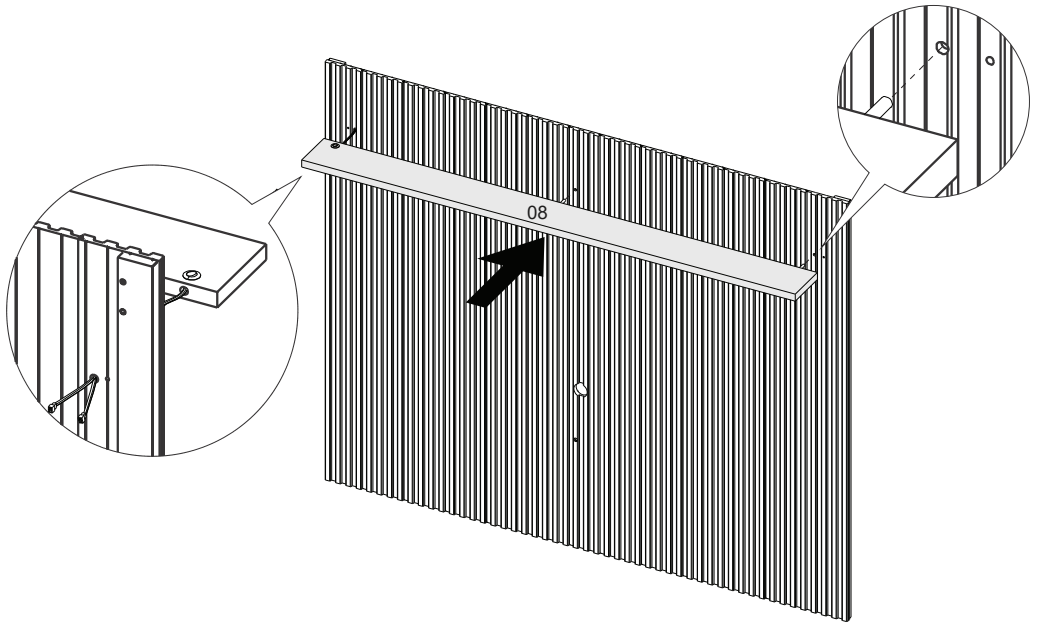

8

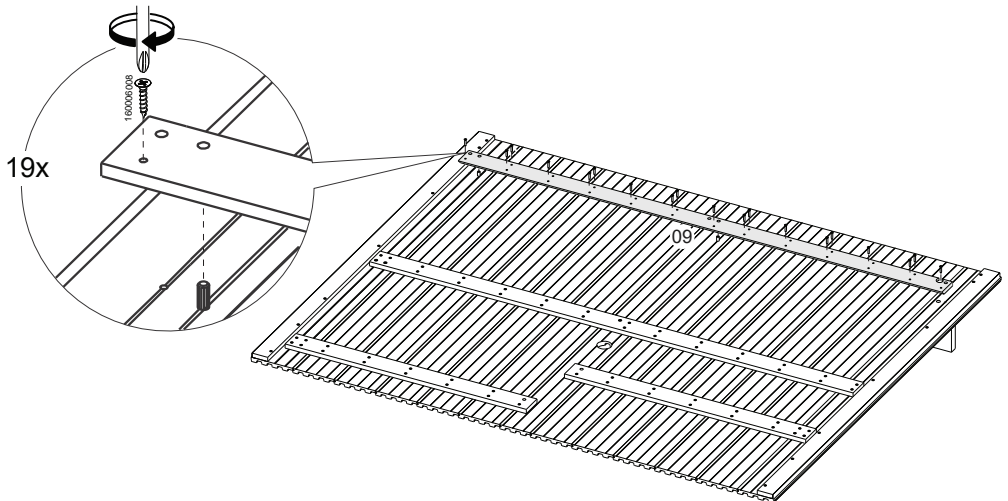
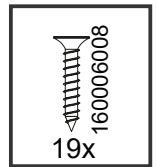

9

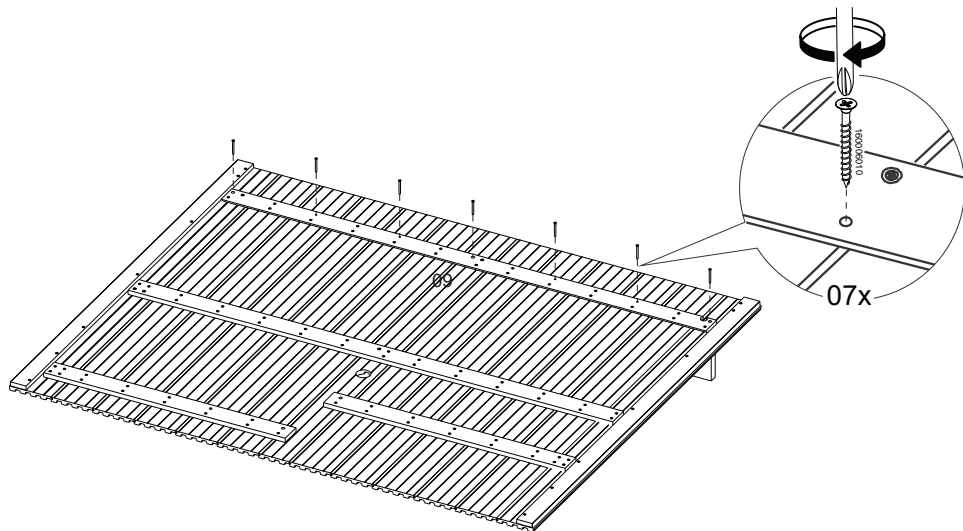
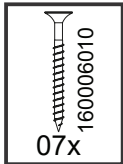

10

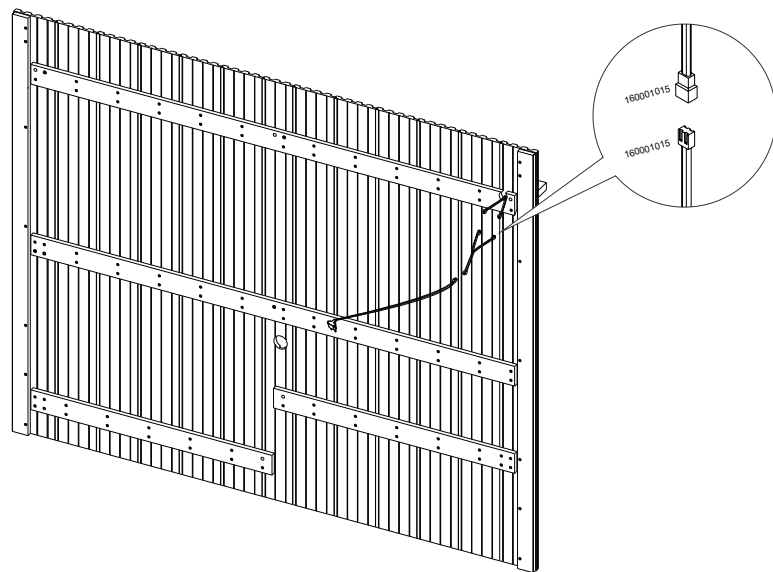
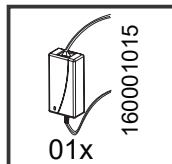

11

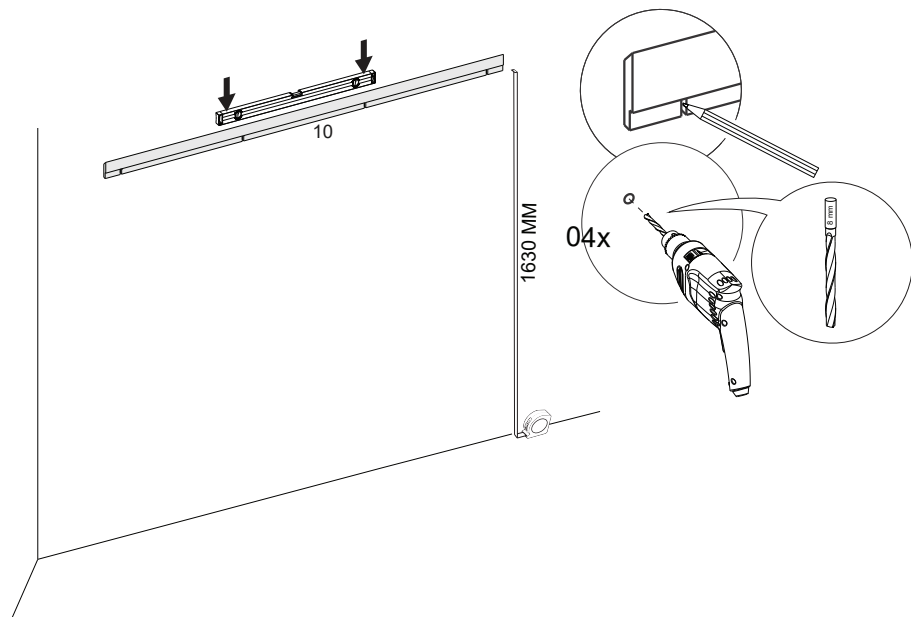

12

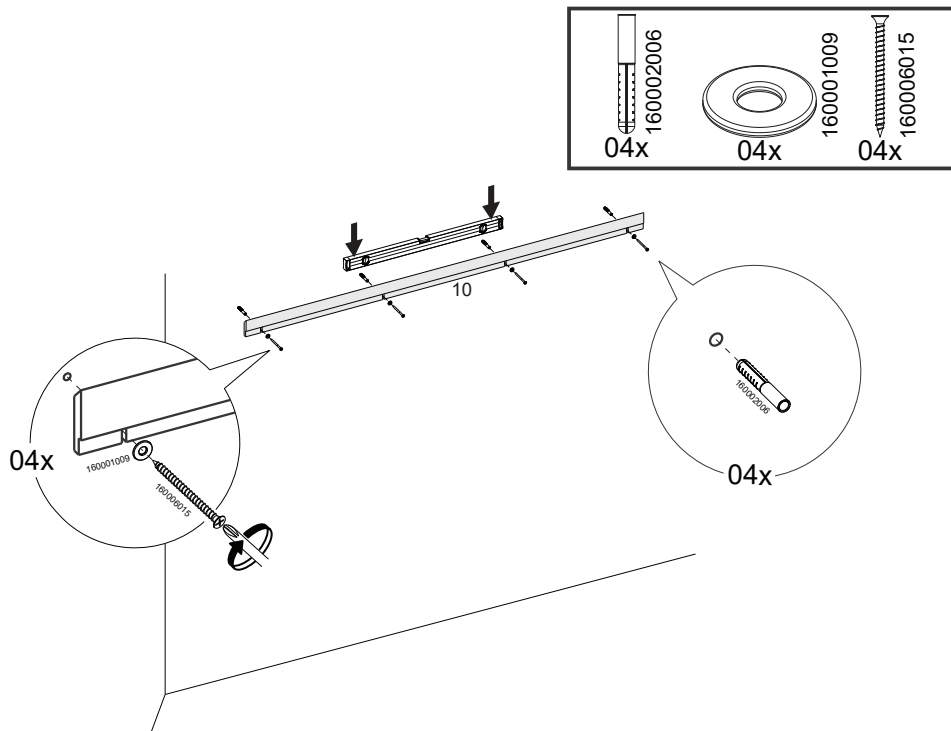

13A

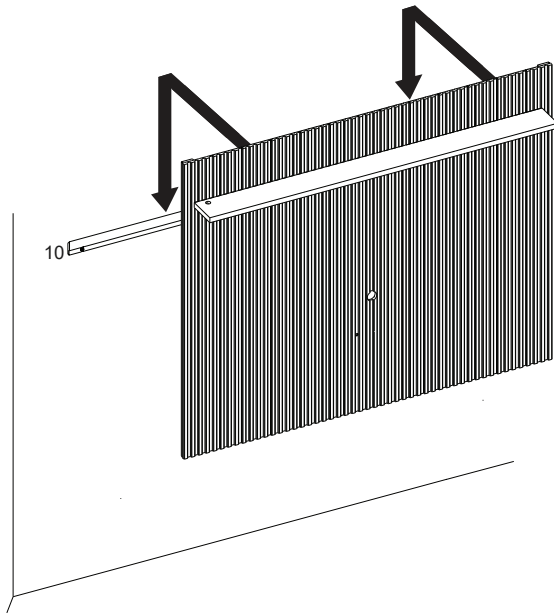

13B

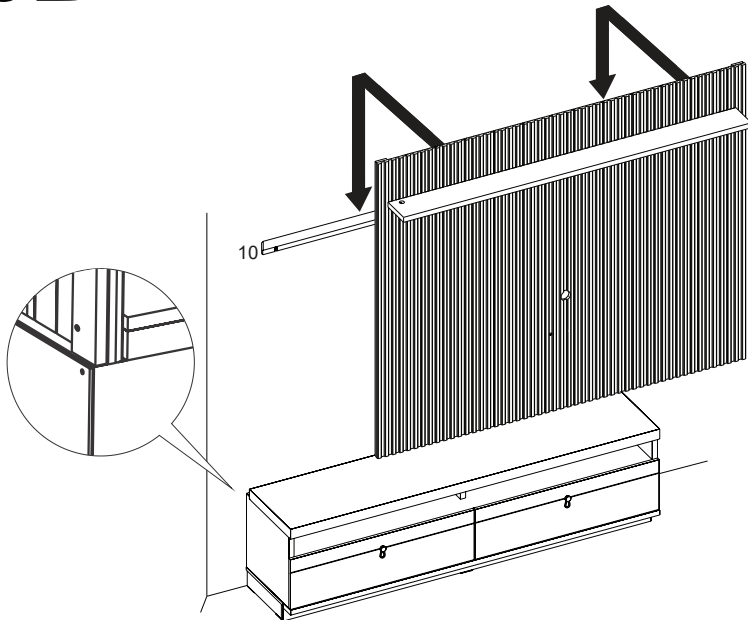

14

