

HOME ALAGOAS

V-6 30/06/25

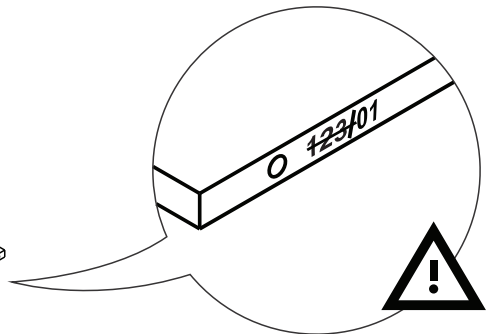
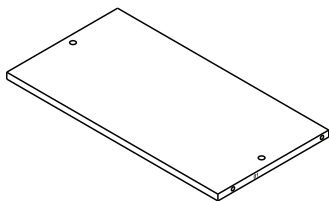
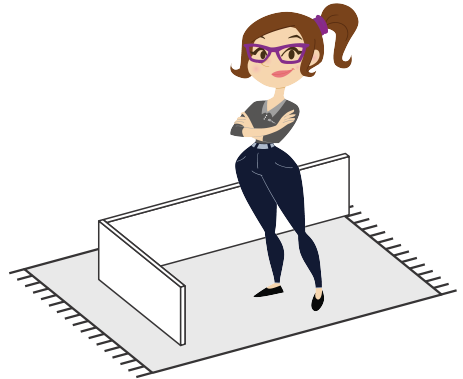
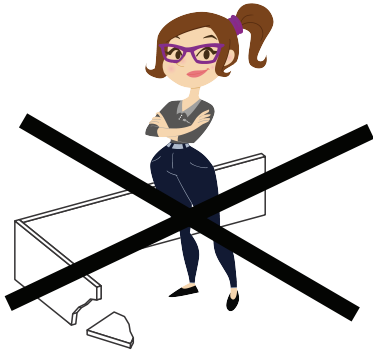
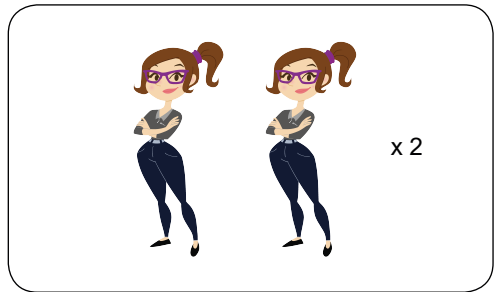
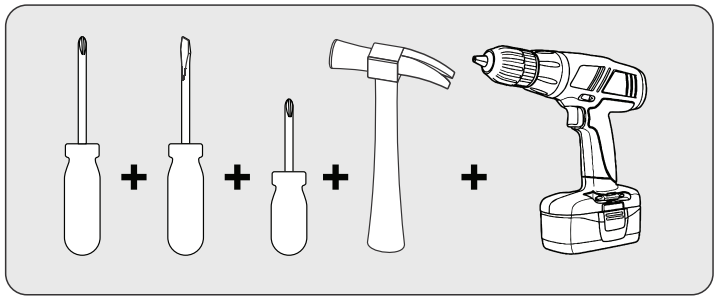
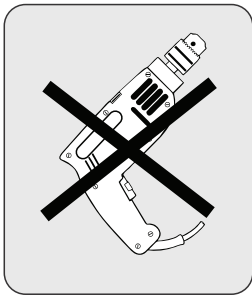

GARANTIA / GARANTIA / WARRANTY

Nossos produtos são garantidos por 90 dias contra defeitos de fabricação. Ao constatar um problema coberto pela garantia, entre em contato com a loja onde o produto foi comprado. Ela estará capacitada para atendê-lo da melhor forma diante de cada caso. Reclamações de garantia somente poderão ser atendidas se o termo de garantia for apresentado no ato de reivindicação, acompanhado de sua nota fiscal de compra.

Nuestros productos están garantidos contra defectos de fabricación por 90 días, a partir de la compra. Ao constatar un problema protegido por la garantía, póngase en contacto con la tienda donde se adquirió el producto. Ella estará capacitada para atenderlo de la mejor manera de acuerdo con cada caso.

Our products are guaranteed against manufacturing defects for 90 days from the date of purchase. When you find a problem covered by the warranty, please contact the store where the product was purchased. The store is able to serve you in the best way in each case.

Exclusões

- Desgaste natural ou danos causados por água, maresia, ferrugem, incêndio, calor, cupins e pragas em geral.
- Montagem, manutenção e uso inadequado.
- Não cumprimento das recomendações técnicas do esquema.
- Montagens e desmontagens após a primeira instalação.
- Instalações elétricas e outras afins.

Exclusiones

- Desgaste natural o daños causados por agua, maresia, incendios, calor, termitas y plagas en general.
- Montaje, mantenimiento y uso inadecuado.
- No cumplimiento de las recomendaciones técnicas del esquema.
- Montaje y desmontaje después de la primera instalación.
- Instalaciones eléctricas y otras afines.

Exclusions

- Natural wear or damage caused by water, sea, rust, fire, heat, termites and plagues in general.
- Assembly, maintenance and improper use.
- Failure to comply with the technical recommendations of the assembly instructions.
- Assembly and disassembly after first installation.

Importante

A Linea Brasil não autoriza nenhuma pessoa, loja ou entidade assumir em seu nome qualquer outra garantia que não conste no certificado. A fabricante reserva-se no direito de efetuar nos produtos eventuais modificações que considerar necessárias, sem prejudicar as características essenciais. Os produtos terão peças de assistência para reposição no período de 1 ano a contar de sua retirada do mercado, desde que haja matéria-prima equivalente, observando o dispositivo no Art.32 da Lei 8.078/90 (Cód. Defesa do Consumidor). O atendimento para produtos fora de linha é feito por programação especial, através da loja revendedora sob aprovação de consulta prévia ao fabricante.

Importante

Linea Brasil no autoriza a ninguna persona, tienda o entidad a asumir en su nombre cualquier otra garantía que no figure en el certificado. El fabricante se reserva el derecho de efectuar en los productos eventuales modificaciones que considere necesarias, sin perjudicar las características esenciales. Los productos tendrán piezas de asistencia para reposición en el período de 1 año a partir de su retirada del mercado. La atención para productos fuera de línea es hecha por programación especial, a través de la tienda revendedora bajo aprobación de consulta previa al fabricante.

Important

Linea Brasil does not authorize any person, store or entity to assume on its behalf any other warranty that does not appear on the certificate. The manufacturer reserves the right to make in the products any modifications that it considers necessary without prejudice to the essential characteristics. The products will have replacement parts within one year of being withdrawn from the market. The service for off-line products is done by special programming, through the store reseller under prior consultation with the manufacture.

INSTRUÇÕES DE LIMPEZA E CONSERVAÇÃO

INSTRUCCIONES PARA LA LIMPIEZA E CONSERVACION / CLEAN AND PRESERVATION INSTRUCTURE

Para retirar o pó, utilize um pano seco, espanador ou aspirador. Se necessário, para uma limpeza mais efetiva, utilize um pano levemente umedecido com água. Finalize com uma flanela limpa e seca.

Para eliminar el polvo, utilice un paño seco, mopa o la aspiradora. Si es necesario, para una limpieza más eficaz, utilice un paño ligeramente humedecido con agua. Terminar con un paño limpio y seco.

To take dirty, use a dry cloth, duster or vacuum. If necessary to take the dust, use a wet cloth. Finish with a clean and dry flannel.

IMPORTANTE / IMPORTANTE / IMPORTANT



Não utilize produtos abrasivos como álcool e detergentes, como também esponjas rígidas ou palha de aço na limpeza dos móveis.
No use limpiadores abrasivos como alcohol y detergentes, así como esponjas rígidas o lana de acero para limpiar los muebles.
Do not use abrasives such as alcohol and detergent, tough soaker also steel wool to clean the furniture.



Proteja a superfície do móvel de objetos que transmitam calor ou umidade.
Proteja la superficie del mueble de objetos que transmitan calor o humedad.
Protect the surface of the furniture against objects that can pass heat and humidity.



Evitar o contato de água e produto de limpeza com o rodapé do produto, pois poderá danificá-lo.
Evitar el contacto con agua y producto de limpieza con el rodapé del producto, pues podrá dañarlo.
Avoid the contact of water and cleaning products with baseboard, cause it should damage your product.



Procure sempre utilizar flanela limpa e seca para a limpeza.
Busque siempre utilizar flanela limpia y seca para la limpieza.
Try always to use a clean and dry flannel to cleaning.



Cuidado com objetos pontiagudos, eles podem arranhar a superfície das portas e tampo.
Cuidado con objetos afilados, ellos pueden rayar la superficie de las puertas e la tapa.
Take care with sharp objects, they can scratch the door/lid surface.

INSTRUÇÃO DE INSTALAÇÃO DE TELEVISORES

INSTRUCCIÓN DE INSTALACIÓN DE TELEVISIÓN / TELEVISION INSTALLATION INSTRUCTION

Para o uso do maior televisor indicado recomendamos a instalação da TV no painel do produto.
Para utilizar el televisor más grande indicado, recomendamos la instalación del televisor en el panel del producto.
To use the largest television indicated, we recommend installing the TV on the product panel.

TAMANHO DE TV SUGERIDO
TAMANO DE TELEVISOR SUGERIDO
SUGGESTED TV SIZE

50"

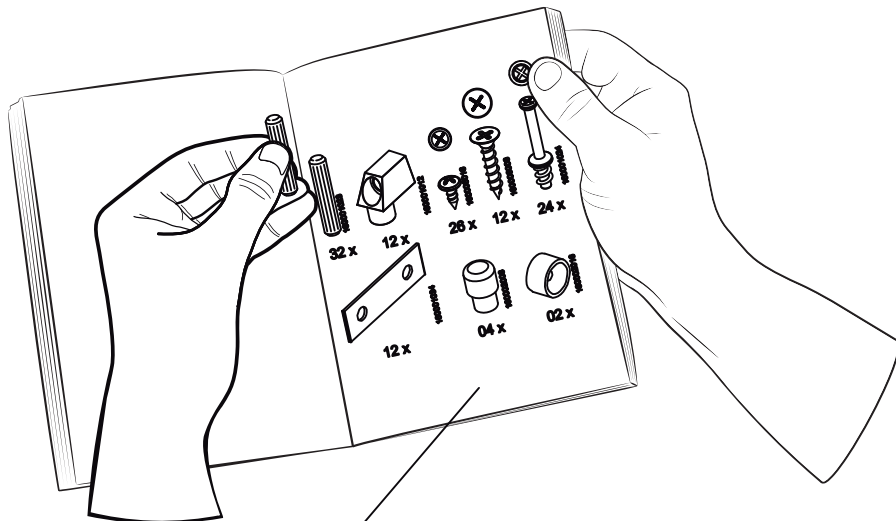

Preste Atenção! ¡Preste atención! Attention!



As ferragens dos nossos manuais são sempre apresentadas nas mesmas proporções da peça na vida real. Caso apareça alguma dúvida no decorrer do processo de montagem, coloque a ferragem ao lado do desenho e faça a consulta :D

Los accesorios de nuestros manuales siempre se presentan en las mismas proporciones que la pieza en la vida real. Si tiene alguna duda durante el proceso de montaje, coloque los accesorios junto al dibujo y haga una consulta :D

The accessories in our manuals are always presented in the same proportions as the spare part in real life. If you have any questions during the assembly process, place the accessory next to the drawing and make an inquiry :D

Símbolos: Símbolos: Symbols:



- + Parafuso Phillips
- Parafuso Fenda
- ⬡ Parafuso Allen

- + Tornillo Philips
- Tornillo Ranurado
- ⬡ Tornillo Allen

- + Phillips screw
- Slotted Screw
- ⬡ Allenscrew

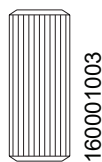

02 x

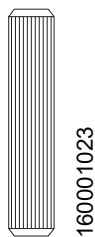

42 x

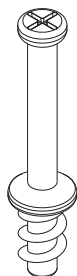

32 x



194 x

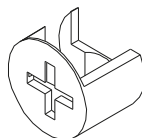

32 x

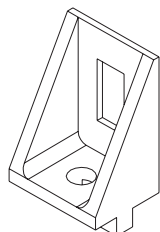

08 x

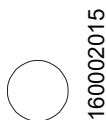

04 x

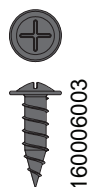

04 x

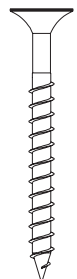

21 x

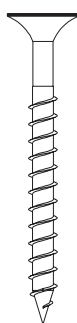

04 x

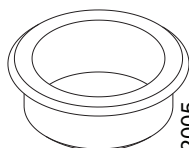

01 x

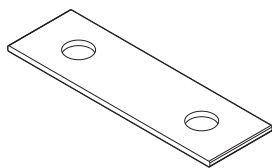

20 x



07 x



49 x

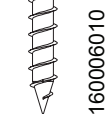

13 x



04 x

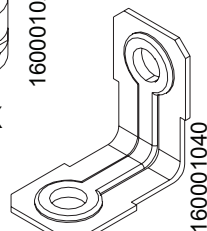

02 x

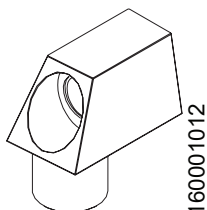

02 x

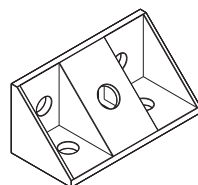

25 x

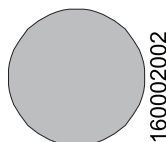

16 x



160003003

A

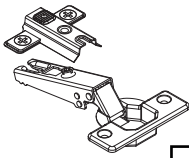

04x

B

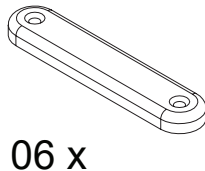
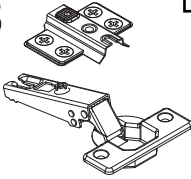

06 x

160002004

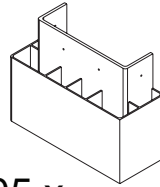

05 x

160009010
160009060
160009075

Usar este puxador para montagem do produto na derivação DOURADO/OFF WHITE FOSCO:

Use this handle for product assembly in the color GOLD/OFF WHITE:

Utilice este tirador para el montaje del producto en el color DORADO/OFF WHITE MATE:



02 x

160005085



02 x

160006044

Usar este puxador para montagem nas demais derivações:

Use this handle for assembling in the other color options:

Utilice este tirador para el montaje en los demás colores:

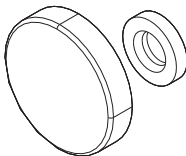

02 x

160005056



02 x

160006020



02 x

160006022



02 x

160005055

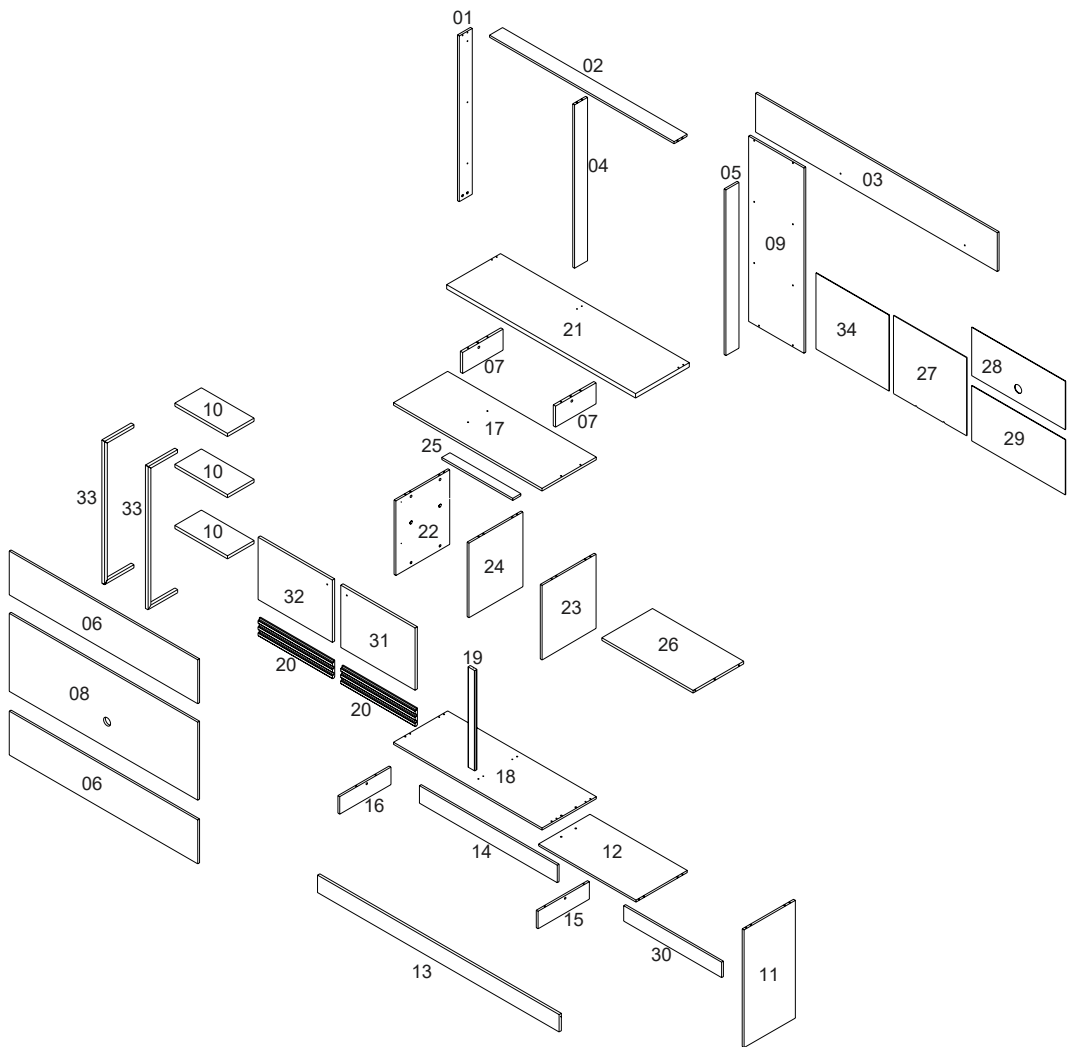

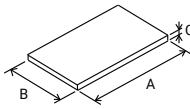

VOLUME Caja Box	ITEM Artículo Item	PEÇA Pieza Part	DESCRIPCIÓN Descripción Description	DIMENSÕES (mm) Dimensión/Dimension			QUANTIDADE La Cantidad The Amount	MATERIAL
				A	B	C		
1	1	510258001	TRAVESSA ESQUERDA	949	86	12	1	MDP
1	2	510258002	TRAVESSA SUPERIOR	1220	86	12	1	MDP
1	3	510258003	PAINEL SUPERIOR	1598	223	12	1	MDP
1	4	510258004	TRAVESSA CENTRAL SUPERIOR	935	86	12	1	MDP
2	5	510258005	TRAVESSA DIREITA	949	86	12	1	MDP
2	6	510258006	PAINEL INFERIOR SUPERIOR	1247	252	12	2	MDP
1	7	510258007	DIVISAO DVD	268	120	15	2	MDP
1	8	510258008	PAINEL CENTRAL TV	1247	447	12	1	MDP
1	9	510258009	PAINEL ESQUERDO	1060	366	12	1	MDP
1	10	510258010	PRATELEIRA SUPERIOR ESQUERDA	349	176	18	3	MDF
1	11	510258011	LATERAL DIREITA	674	339	12	1	MDP
1	12	510258012	BASE	643	339	12	1	MDP
1	13	510258013	ENCABECAMENTO BASE	1598	100	15	1	MDP
2	14	510258014	RODAPE TRASEIRO ESQUERDO	911	100	12	1	MDP
2	15	510258015	RODAPE CENTRAL	339	100	12	1	MDP
2	16	510258016	RODAPE LATERAL	339	100	12	1	MDP
2	17	510258017	TAMPO PORTA	983	359	15	1	MDP
2	18	510258018	BASE PORTA	983	359	12	1	MDP
1	19	510258019	ENCABECAMENTO LATERAL DIREITO	574	44	15	1	MDF
1	20	510258020	MOLDURA PORTA	492	101	15	2	MDF
2	21	510258021	TAMPO TV	1249	356	25	1	MDP
1	22	510258022	LATERAL PORTA ESQUERDA	427	357	12	1	MDP
1	23	510258023	LATERAL PORTA DIREITA	427	357	12	1	MDP
2	24	510258024	DIVISAO PORTA	427	357	12	1	MDP
1	25	510258025	SUPORTE TAMPO ESQUERDO	469	54	12	1	MDP
2	26	510258026	PRATELEIRA DIREITA	603	335	15	1	MDP
1	27	510258027	FUNDO TRASEIRO PORTA DIR. (COM FURO)	483	447	2,8	1	MDF
1	28	510258028	FUNDO TRASEIRO DIR. SUP. (COM FURO)	619	277	2,8	1	MDF
2	29	510258029	FUNDO TRASEIRO DIREITO INFERIOR	619	316	2,8	1	MDF
1	30	510258030	RODAPE TRASEIRO DIREITO	647	88	12	1	MDP
2	31	510258031	PAINEL PORTA DIREITA	492	357	15	1	MDP
2	32	510258032	PAINEL PORTA ESQUERDA	492	357	15	1	MDP
1	33	510258033	HASTE	820	194	18	2	MDF
1	34	510258034	FUNDO TRASEIRO PORTA ESQUERDA	486	435	2,8	1	MDF
1	19	510258040	ENCABECAMENTO LATERAL DIREITO	574	70	15	1	MDP



Para montagem do produto na derivação DOURADO/OFF WHITE FOSCO, utilizar peça 19 (510258040).

For assembling the product in the GOLD/OFF WHITE color, use piece 19 (510258040).

Para el montaje del producto en el color DORADO/OFF WHITE, utilice la pieza 19 (510258040).

ARTÍCULO	DESCRIPCIÓN
1	PLATO IZQUIERDO
2	PLATO ARRIBA
3	PANEL SUPERIOR
4	PLATO CENTRAL SUPERIOR
5	PLATO DERECHO
6	PANEL INFERIOR SUPERIOR
7	DIVISIÓN DVD
8	PANEL CENTRAL TV
9	PANEL IZQUIERDO
10	ESTANTE ARRIBA IZQUIERDA
11	LATERAL DERECHA
12	BASE
13	ENCABECAMENTO BASE
14	ZÓCALO TRASERO IZQUIERDO
15	ZÓCALO CENTRAL
16	ZÓCALO LATERAL
17	BASE PUERTA
18	BASE PUERTA
19	ENCABECAMENTO LADO IZQUIERDO
20	MARCO PUERTA
21	BASE TV
22	LATERAL PUERTA IZQUIERDA
23	LATERAL PUERTA DERECHA
24	DIVISIÓN PUERTA
25	APOYO BASE IZQUIERDA
26	ESTANTE DERECHA
27	FONDO TRASERO PUERTA DERECHA
28	FONDO TRASERO DERECHO ARRIBA
29	FONDO TRASERO DERECHO ABAJO
30	ZÓCALO TRASERO DERECHO
31	PANEL PUERTA DERECHA
32	PANEL PUERTA IZQUIERDA
33	PROVENIR
34	FONDO TRASERO PUERTA IZQUIERDA

ITEM	DESCRIPTION
1	LEFT PLATTER
2	UPPER PLATTER
3	UPPER PANEL
4	CENTER UPPER PLATTER
5	RIGHT PLATTER
6	BOTTOM UPPER PLATTER
7	DIVISION DVD
8	CENTRAL PANEL TV
9	LEFT PANEL
10	UPPER LEFT SHELF
11	RIGHT SIDE
12	BASE
13	BASE HEADING
14	BOTTOM LEFT BASEBOARD
15	CENTER BASEBOARD
16	SIDE BASEBOARD
17	BASE DOOR
18	BASE DOOR
19	RIGHT SIDE HEADING
20	FRAME DOOR
21	BASE TV
22	LEFT SIDE DOOR
23	RIGHT SIDE DOOR
24	DOOR DIVISION
25	SUPPORT LEFT BASE
26	RIGHT SHELF
27	BOTTOM RIGHT DOOR
28	UPPER BOTTON RIGHT
29	LOW BOTTON RIGHT
30	RIGHT BOTTON BASEBOARD
31	RIGHT PANEL DOOR
32	LEFT PANEL DOOR
33	STEM
34	BOTTOM LEFT DOOR

1

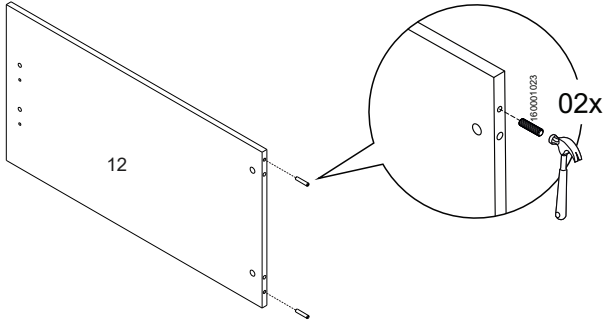
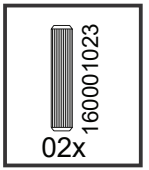

2

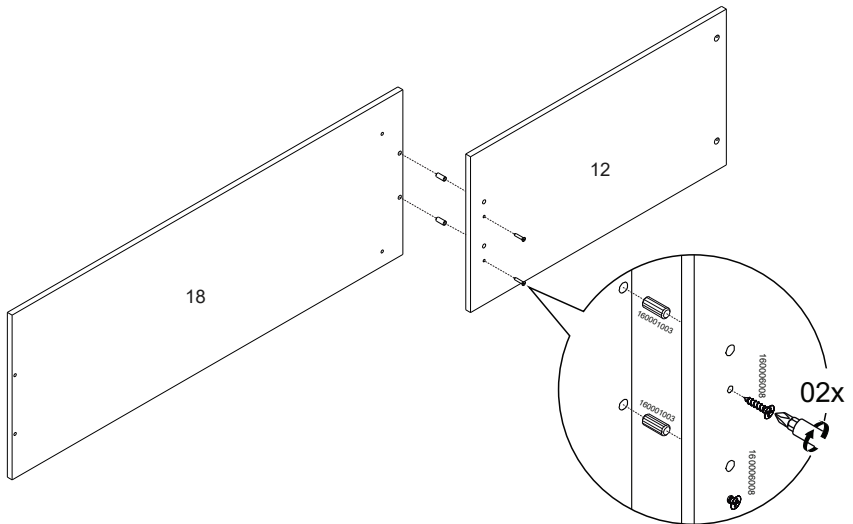
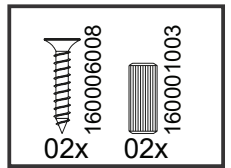

3

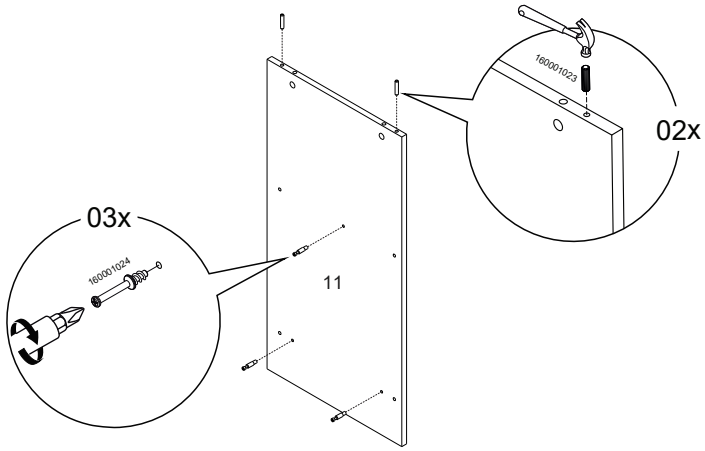
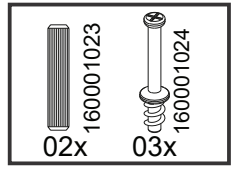

4

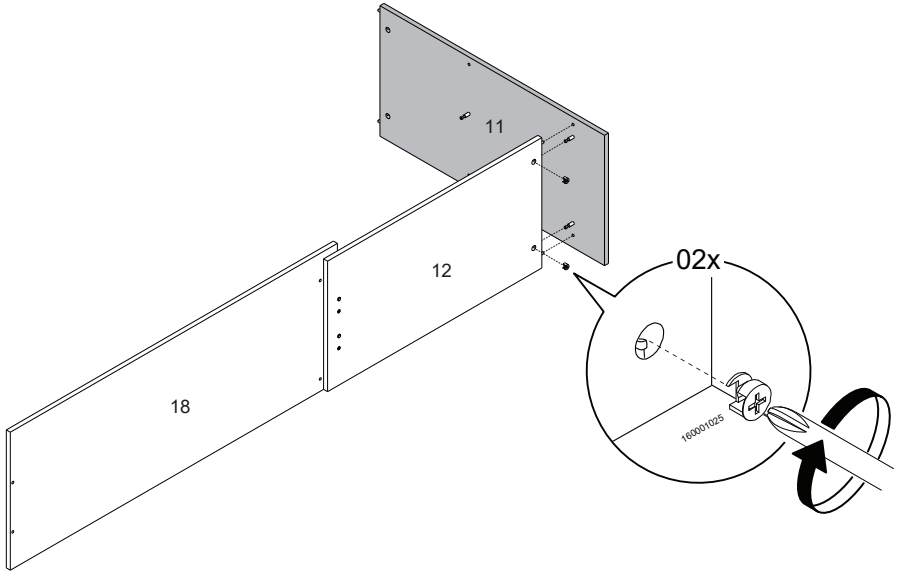
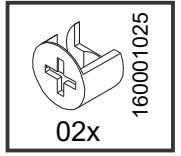
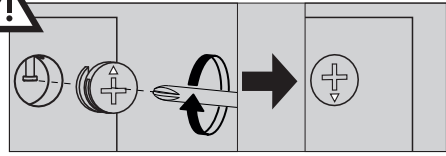

5

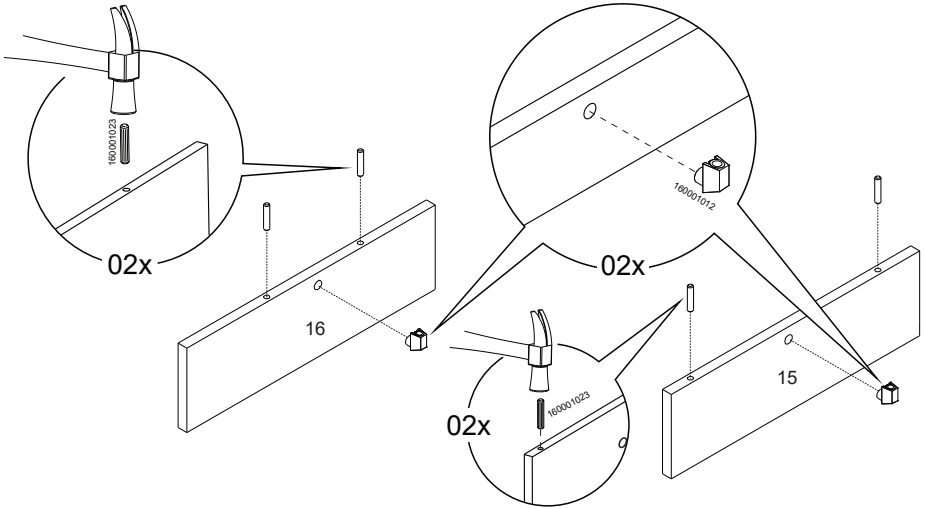
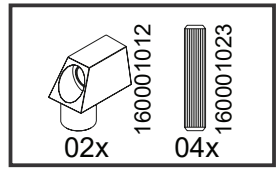

6

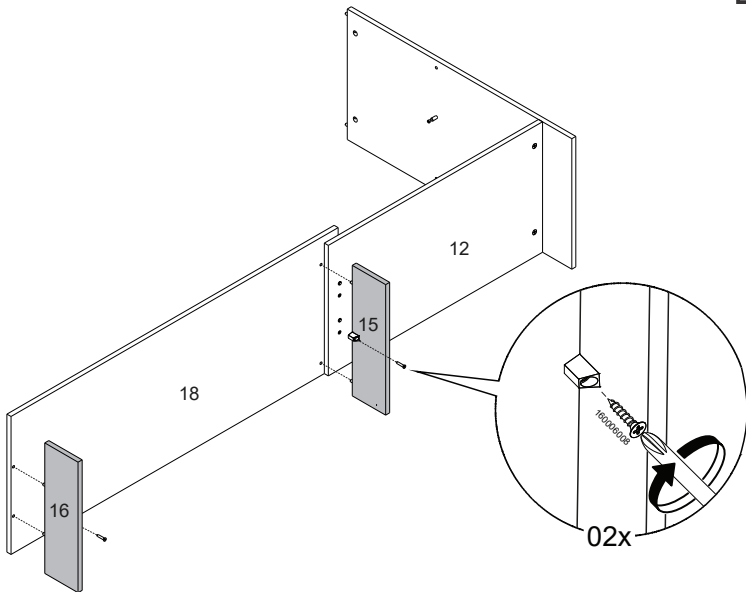
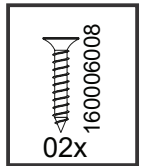

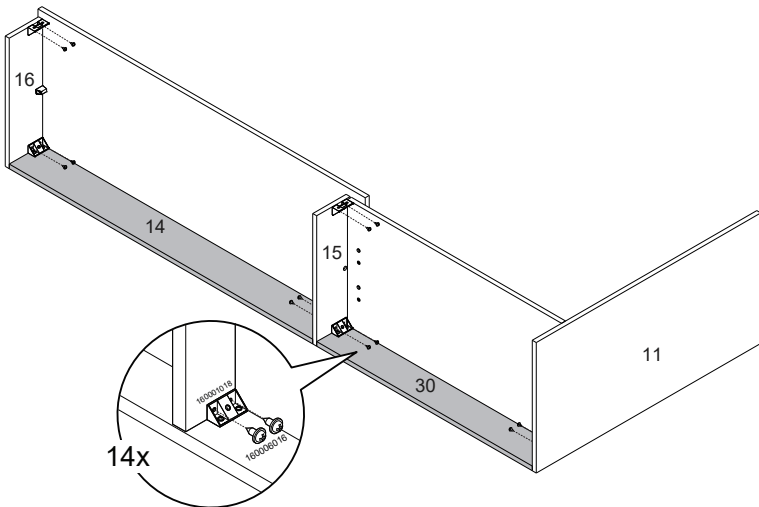
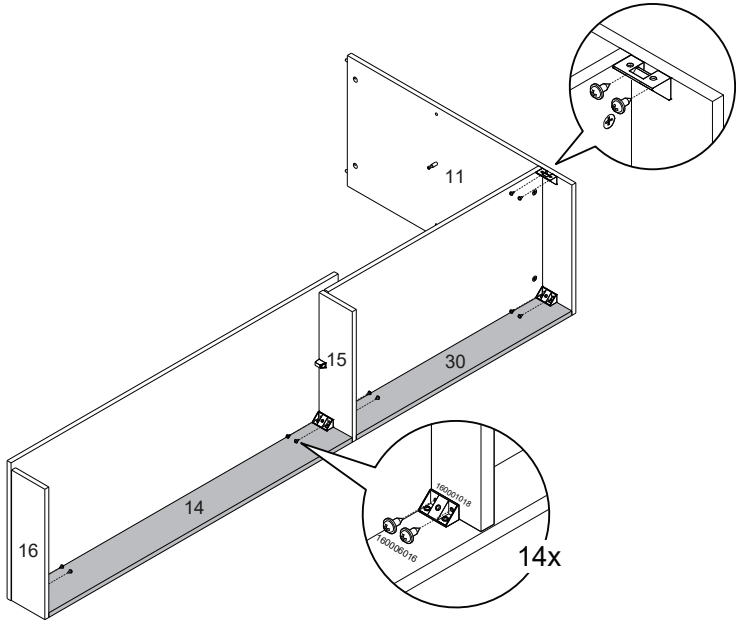
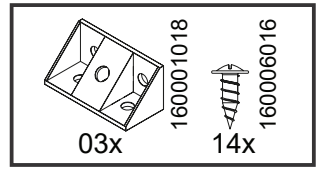

9

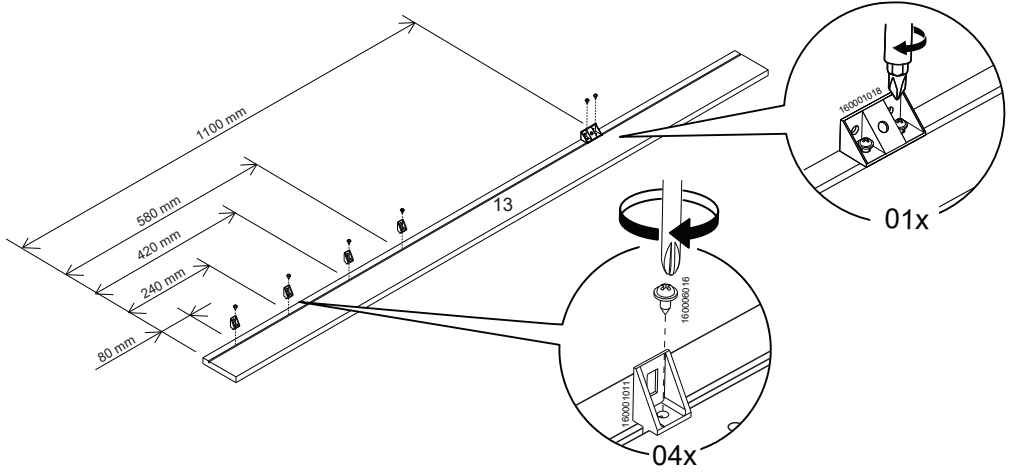
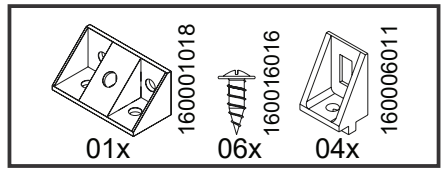

10

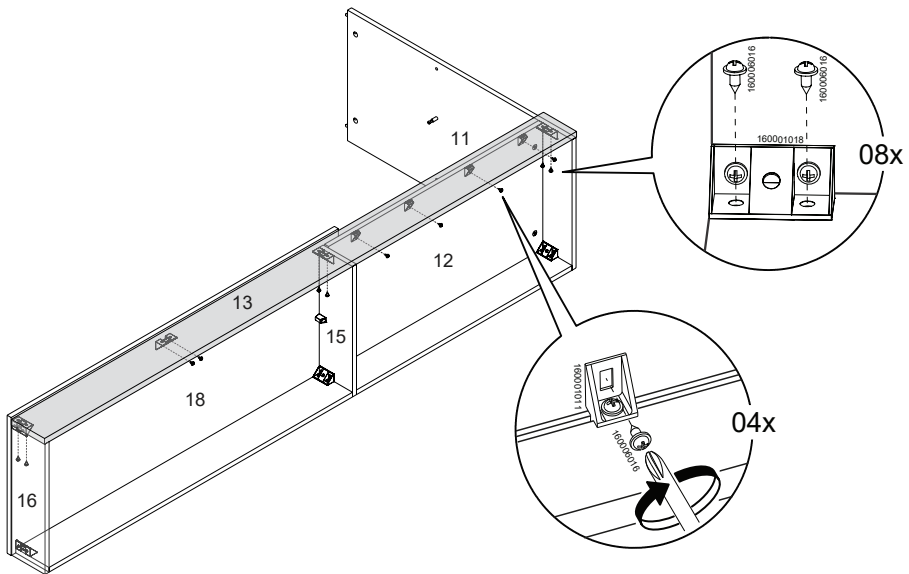
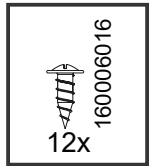

11



Pés opcionais
Optional feet
Pies opcionales

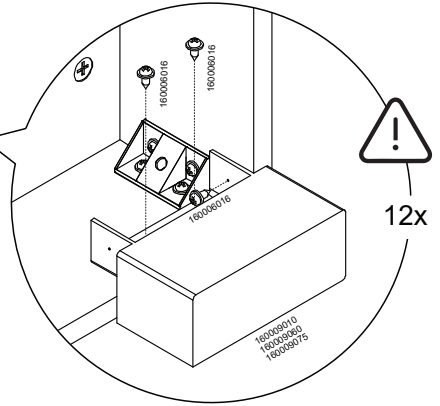
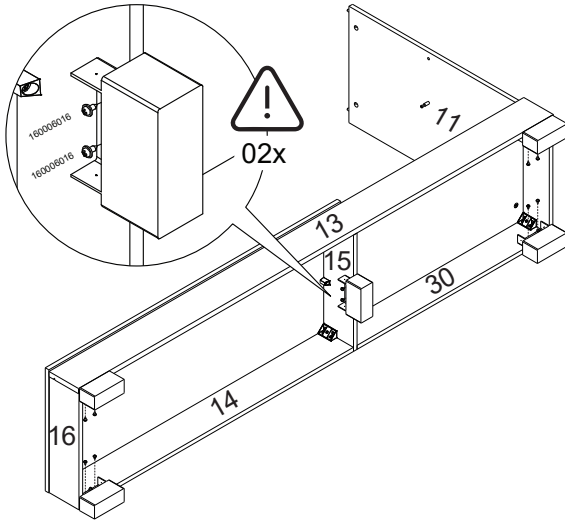
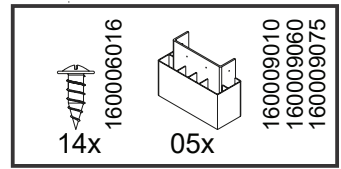

12

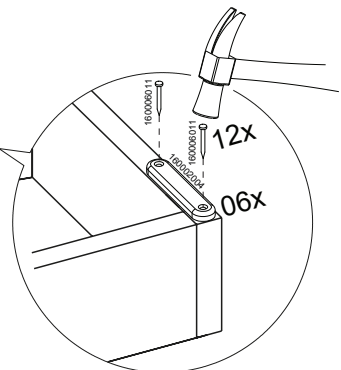
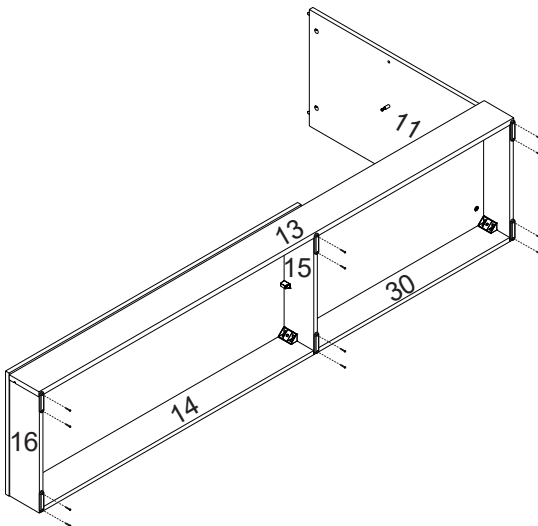
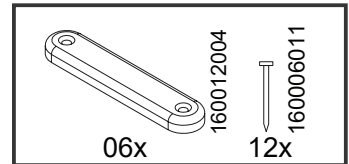

13

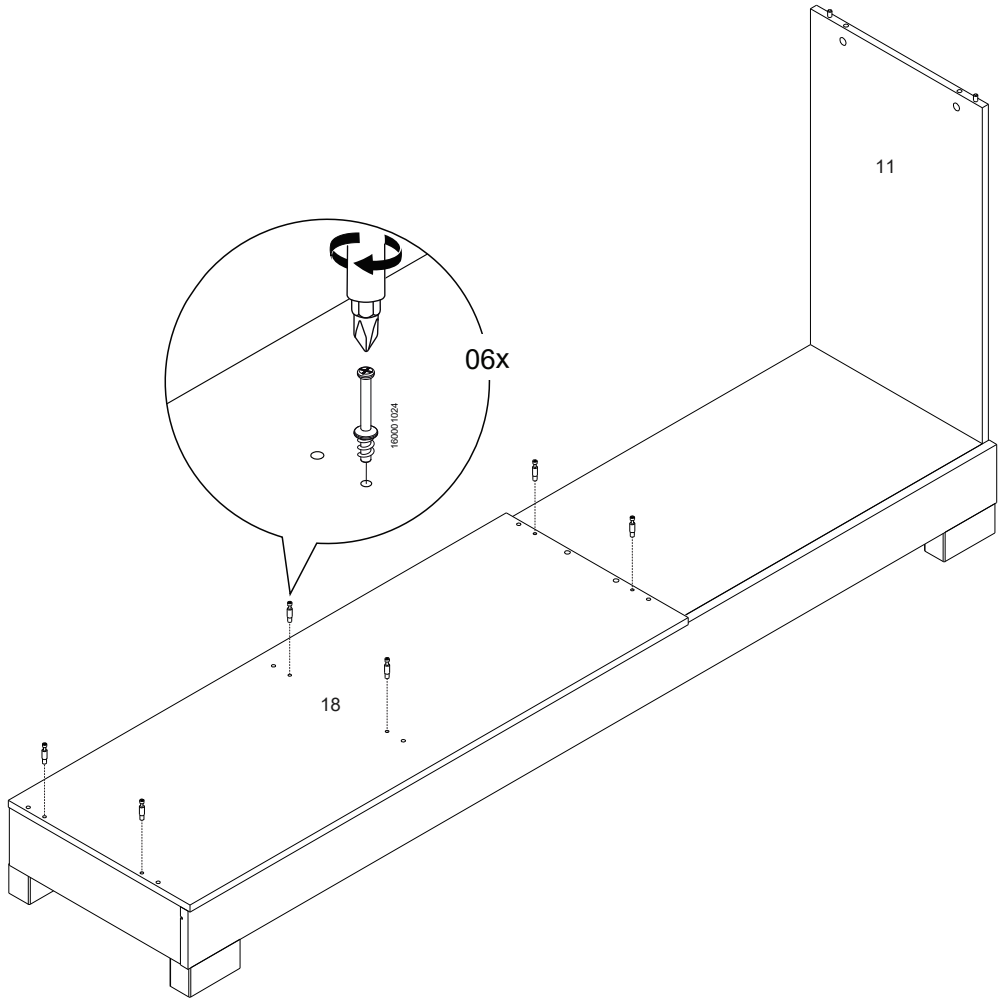
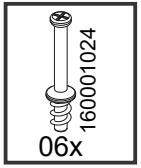

14

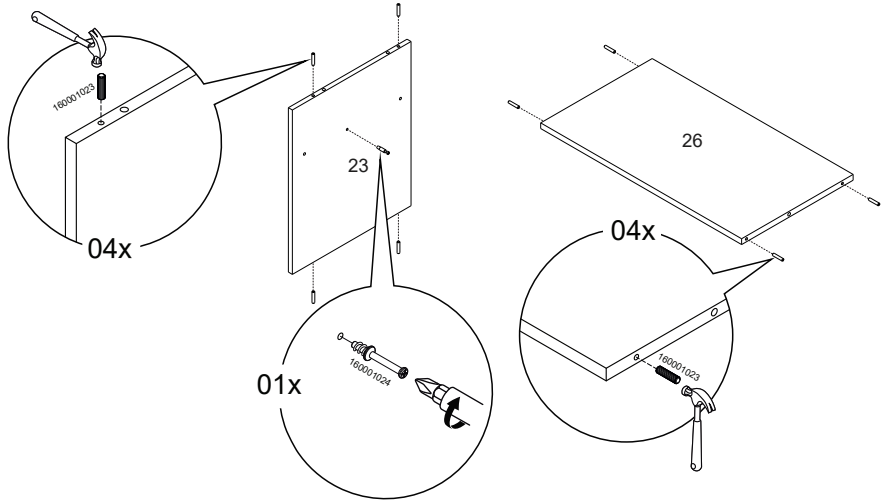
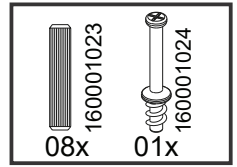

15

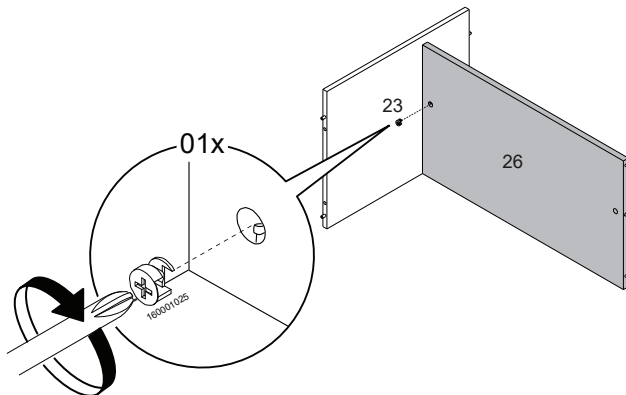
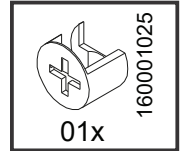
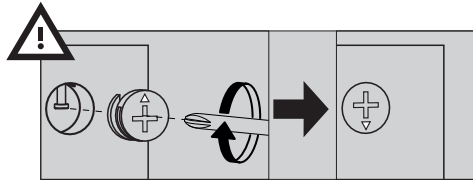

16

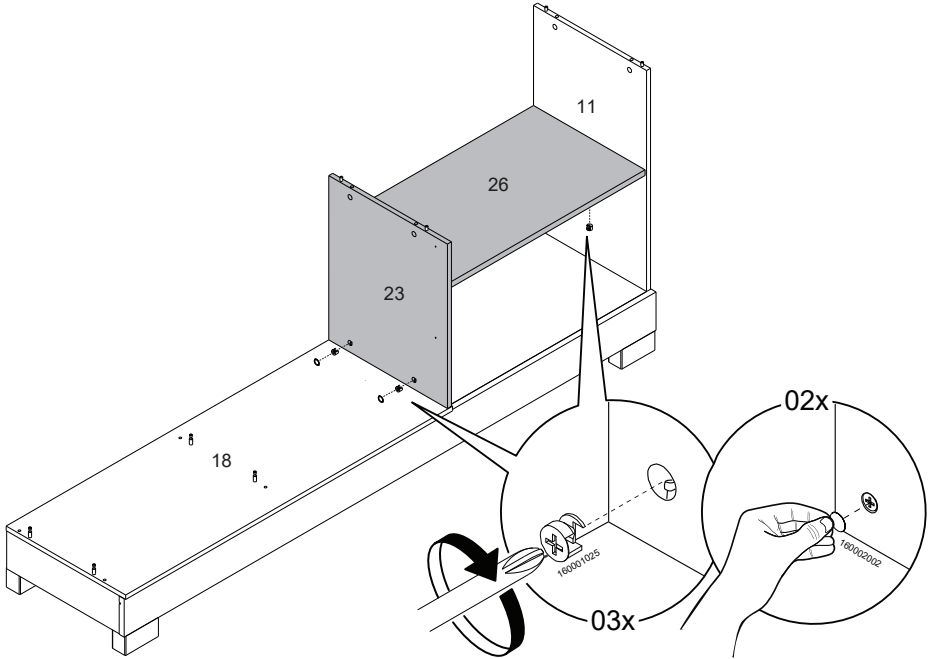
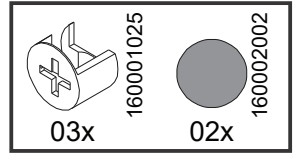
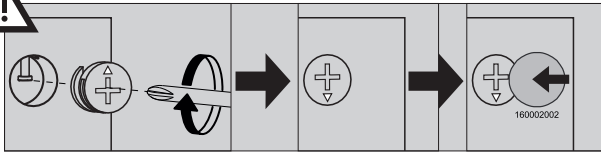

17

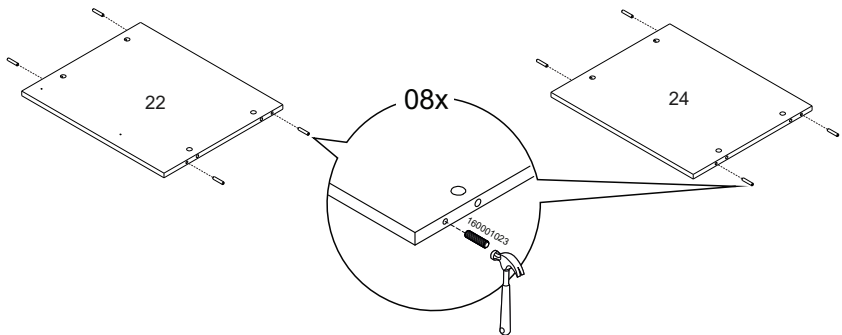
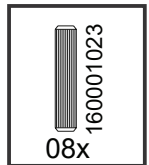

18

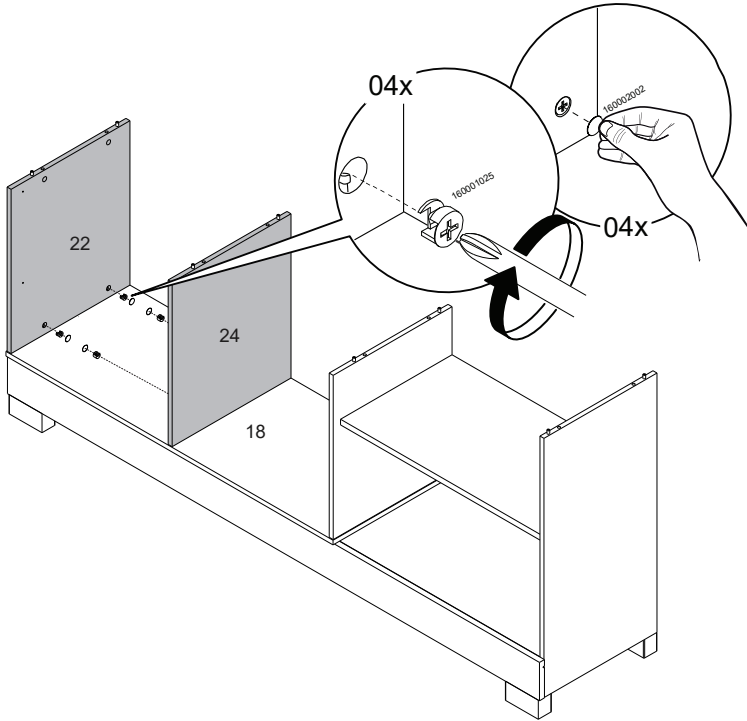
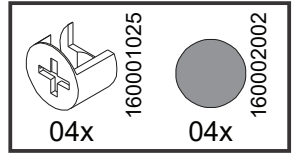
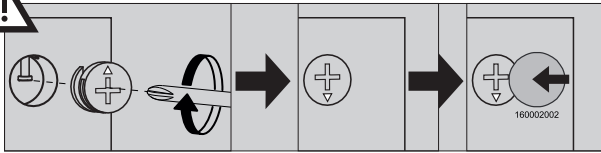

19

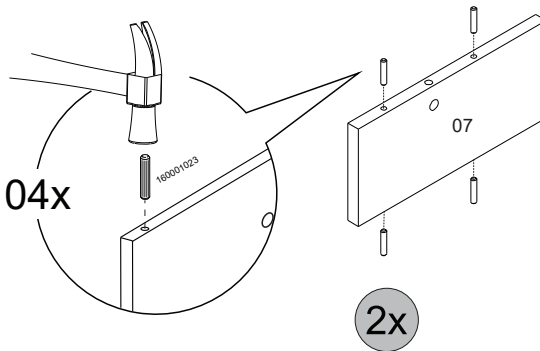
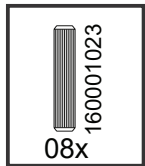

20

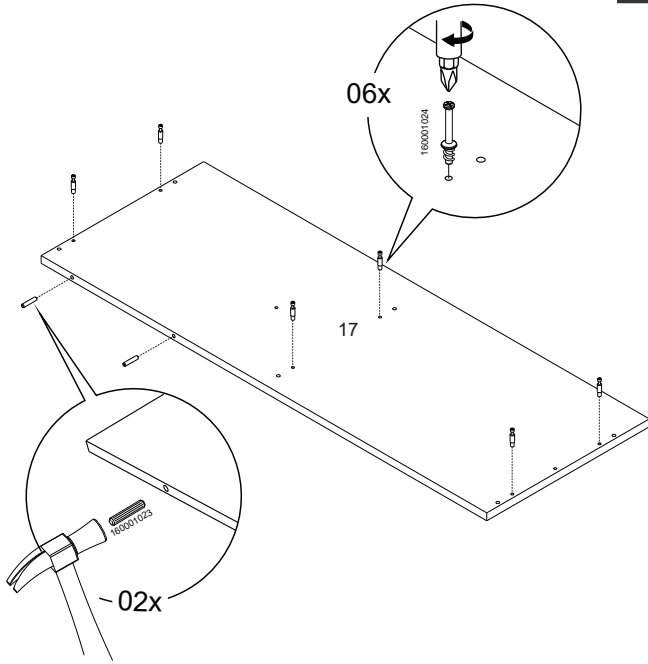
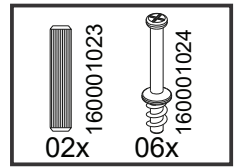

21

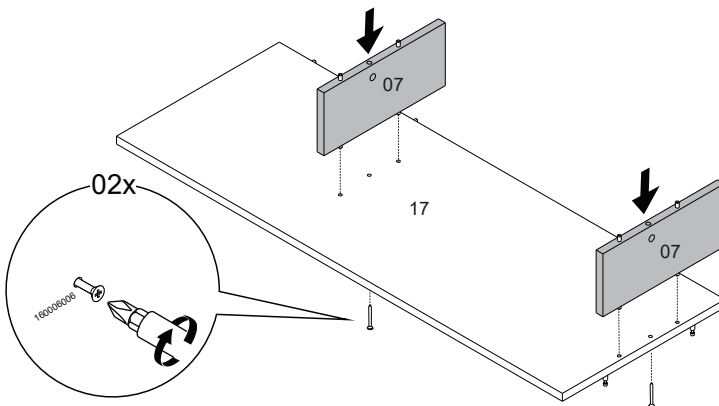
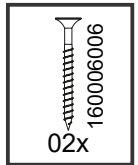

22

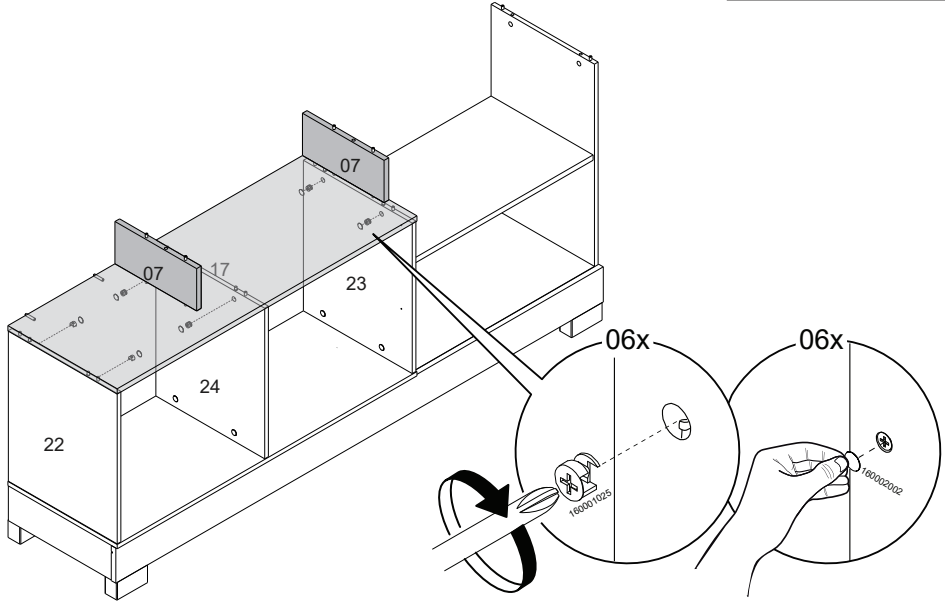
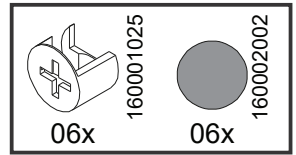
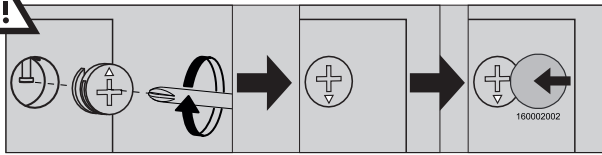

23

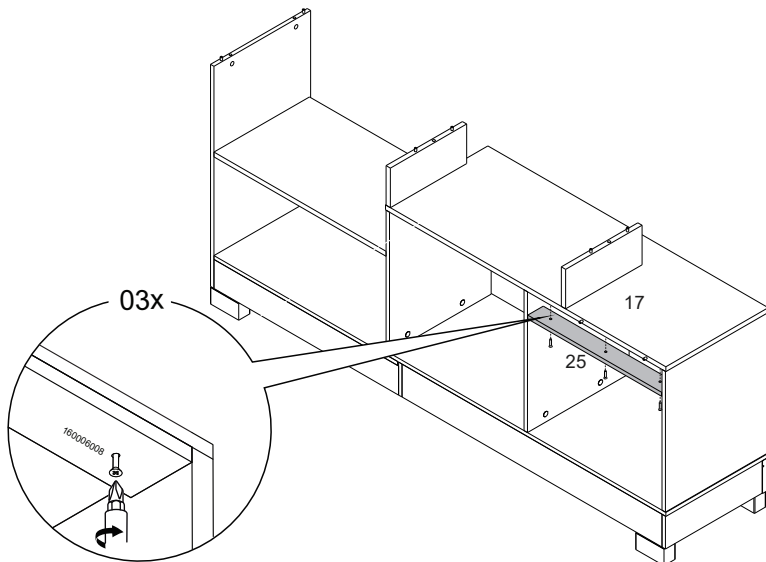
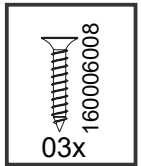

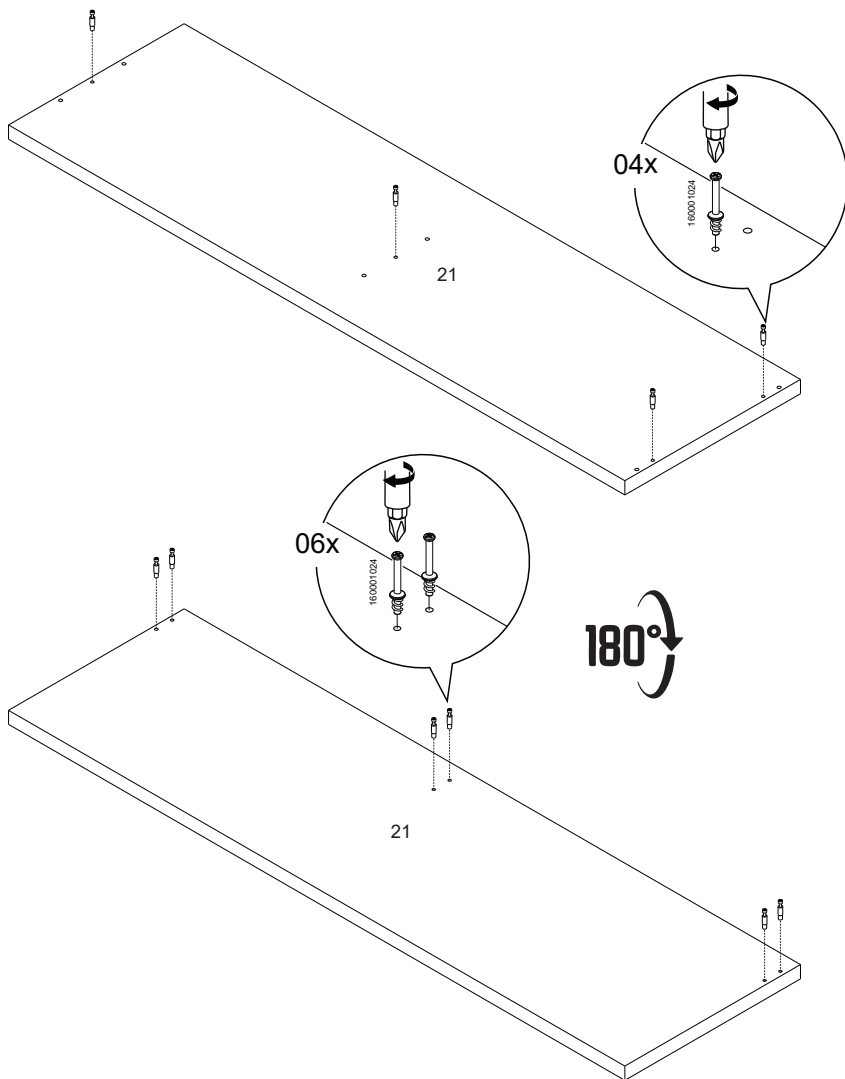
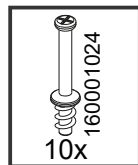

25

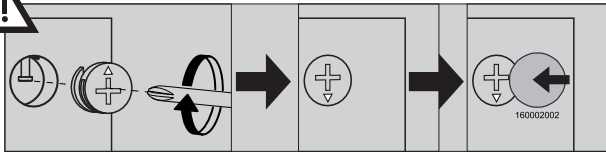

	160001025		160002002
04x		04x	

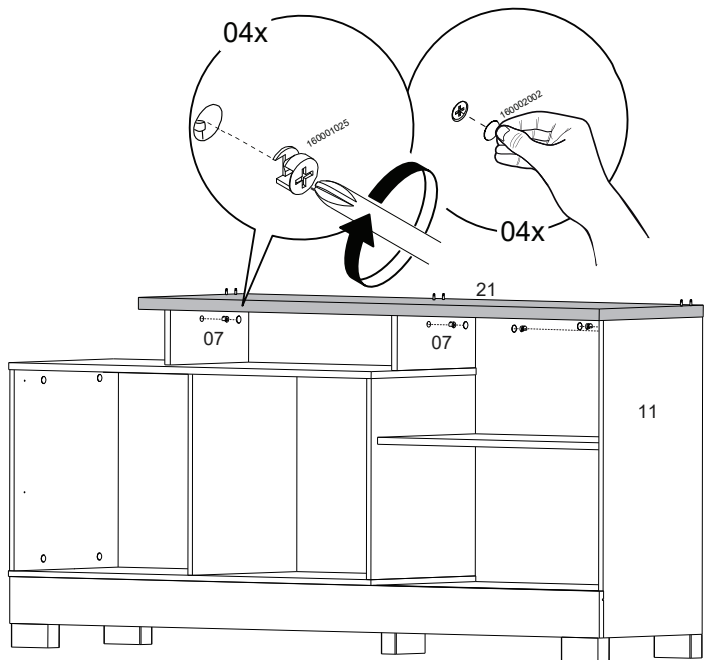

26

	160016016		160006011
04x		04x	

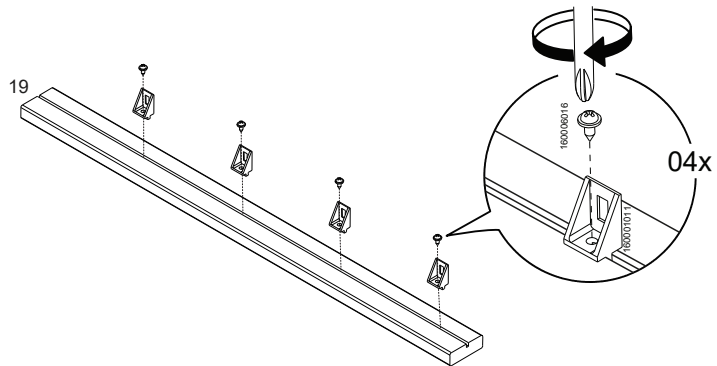

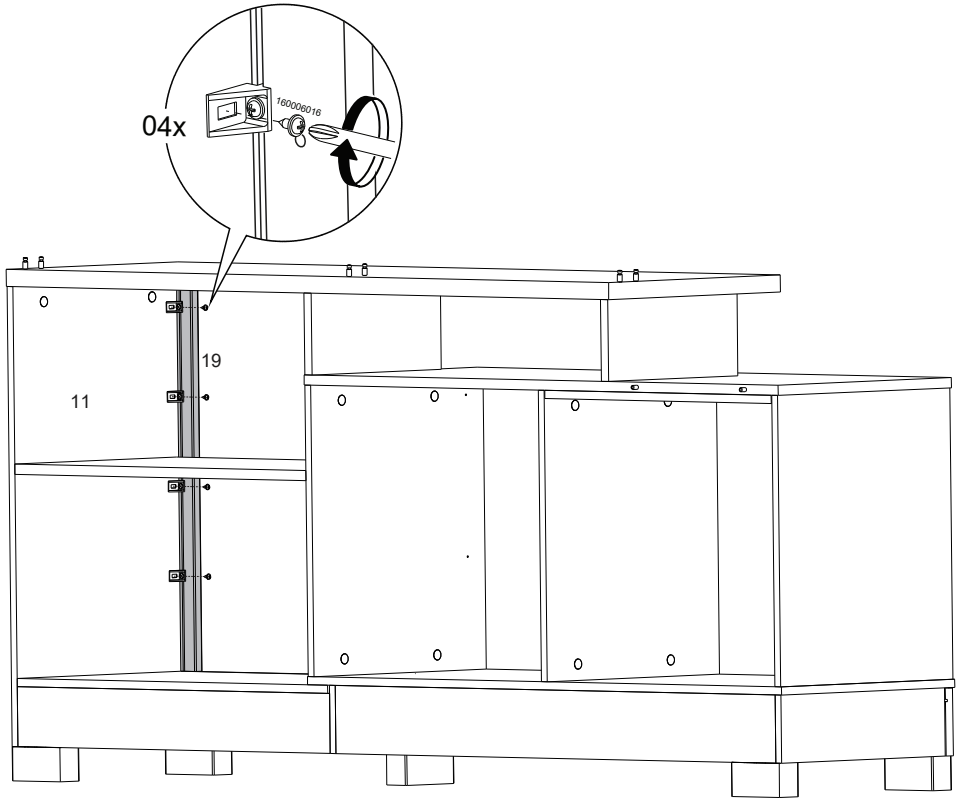

28

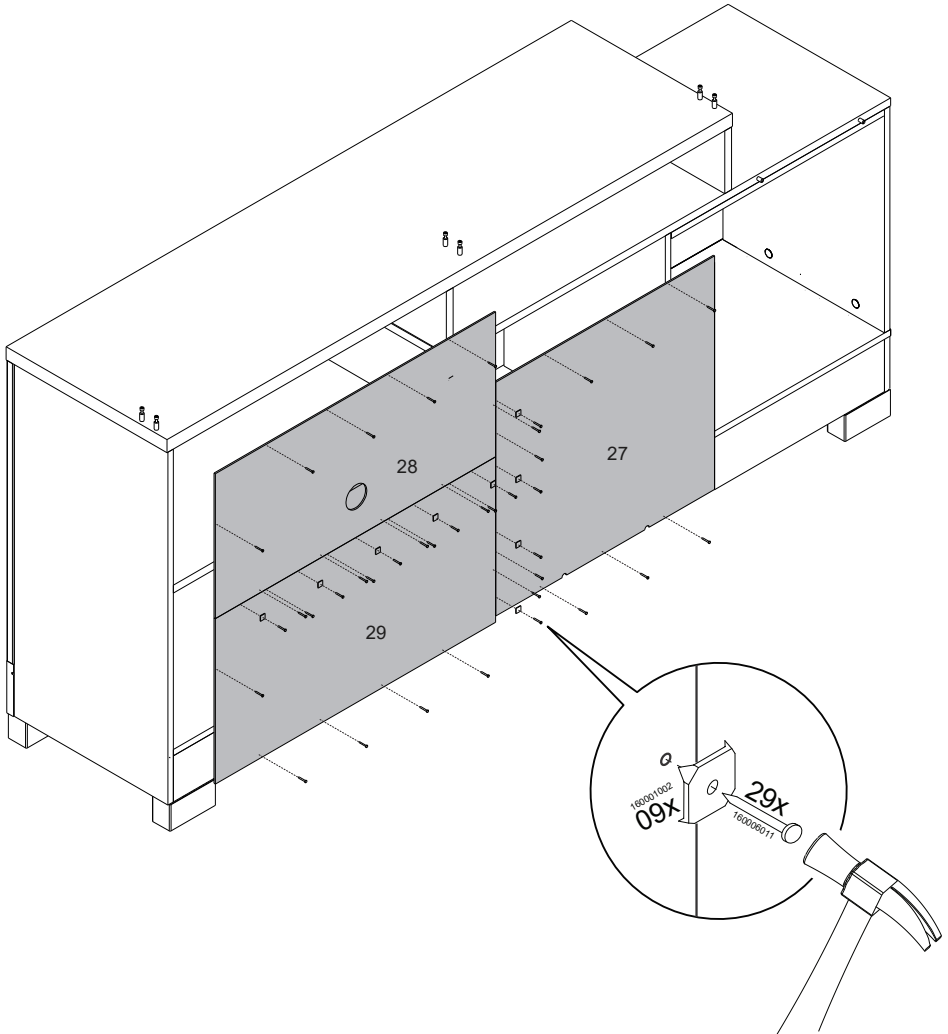
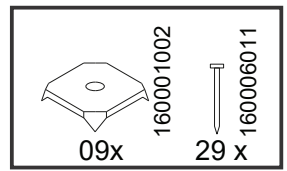

29

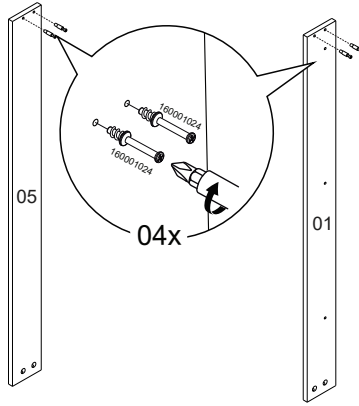
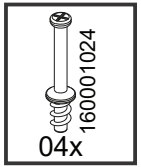

30

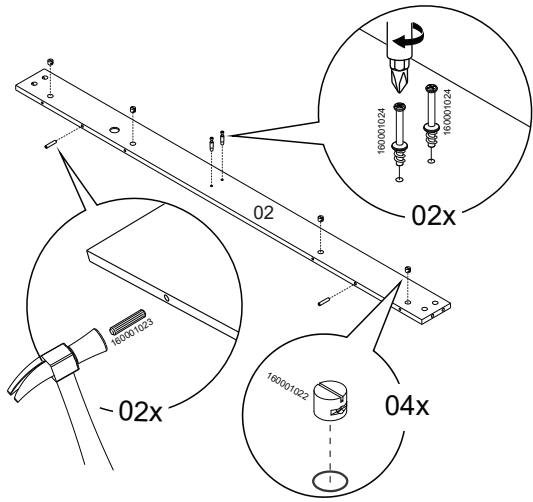
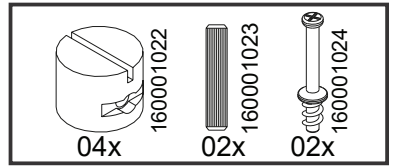

31

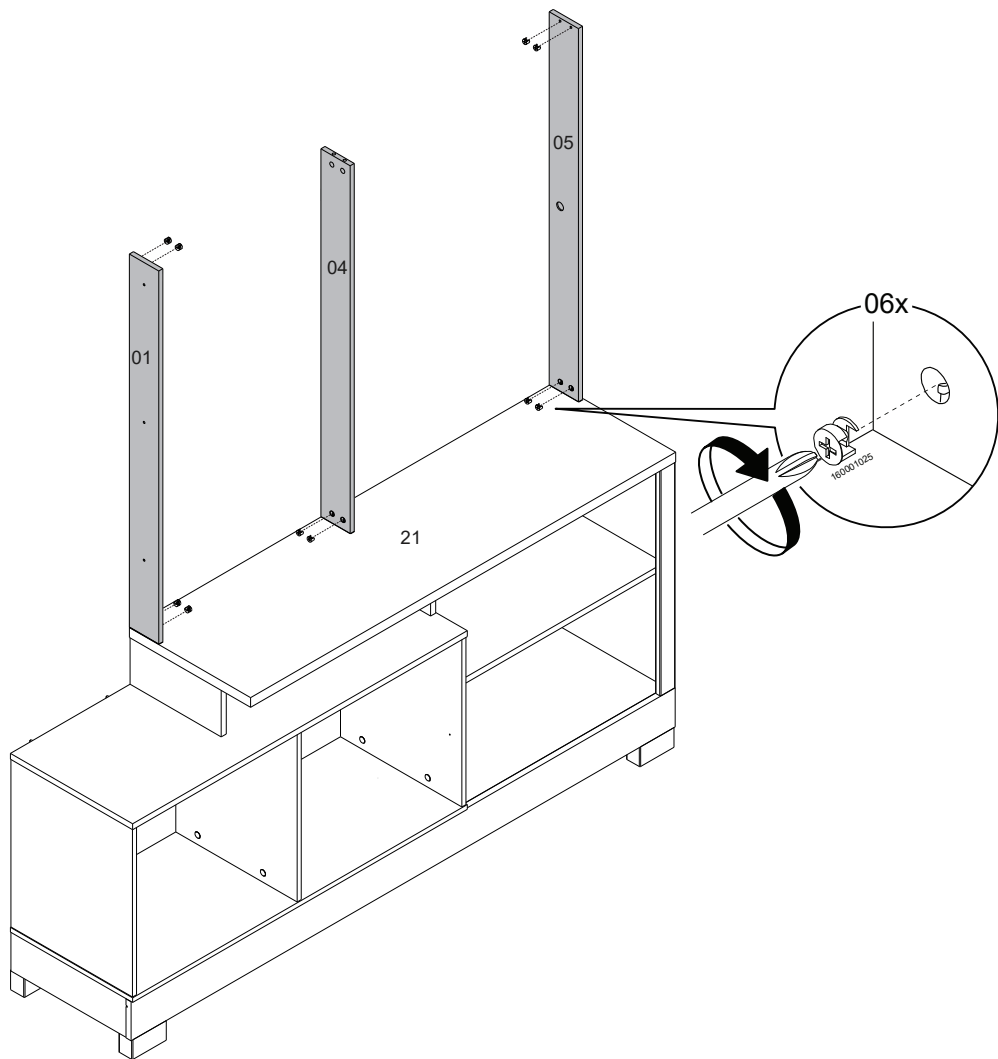
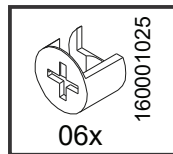
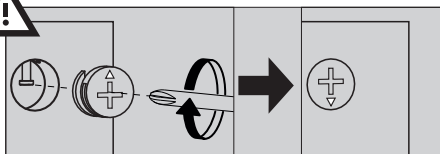

32

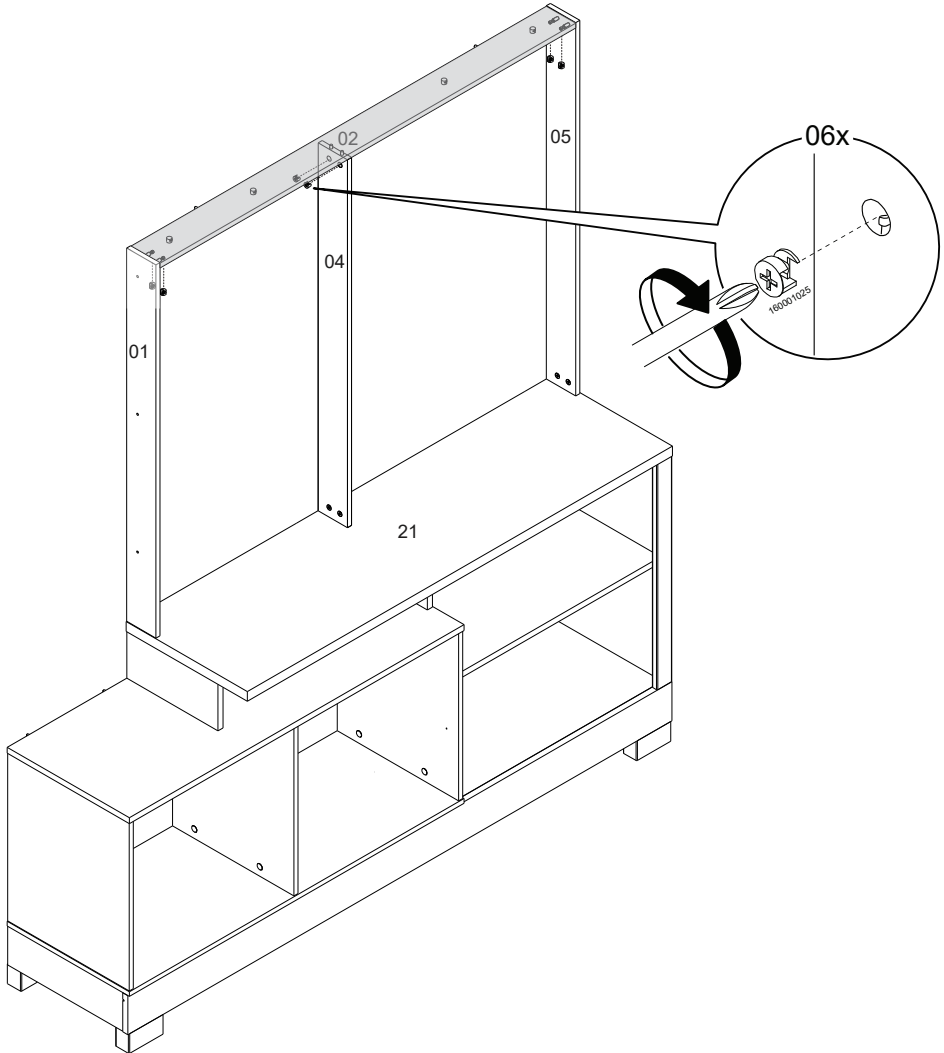
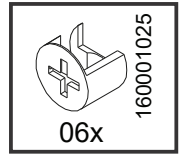
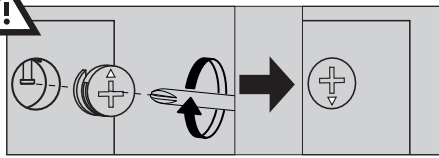

33

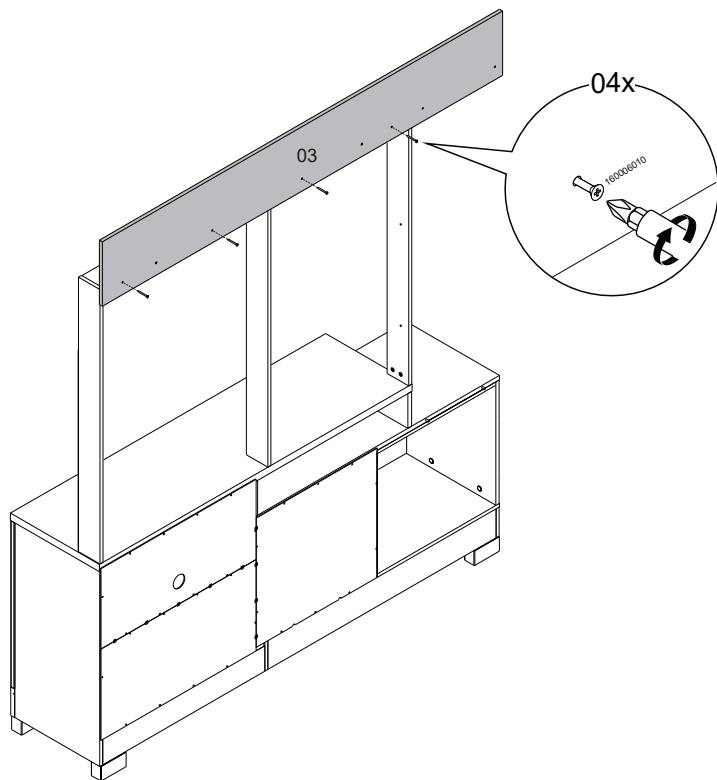
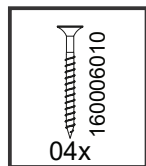

34

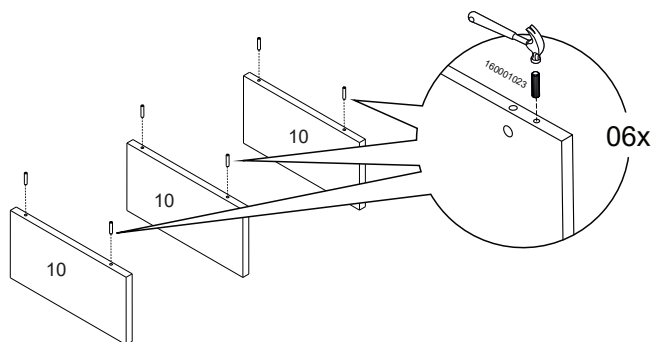
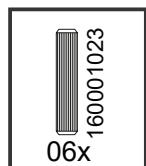

35

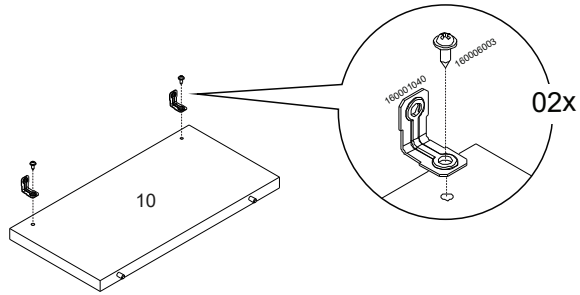
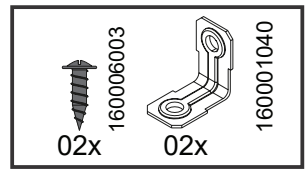

36

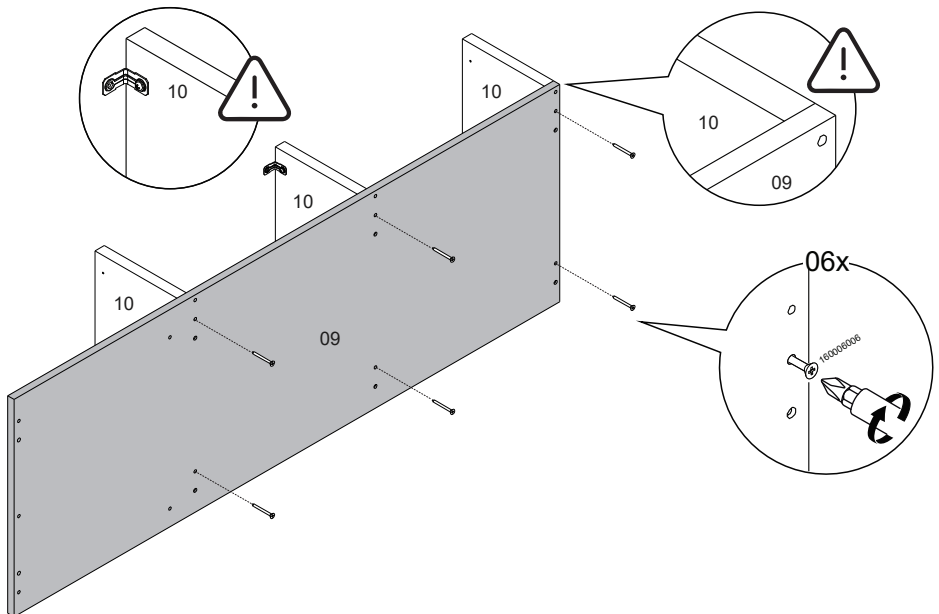
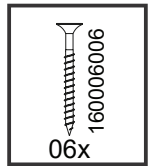

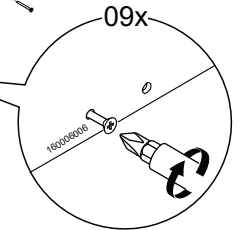
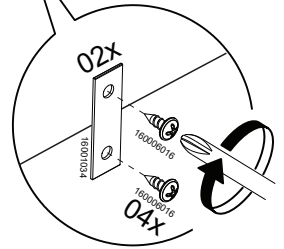
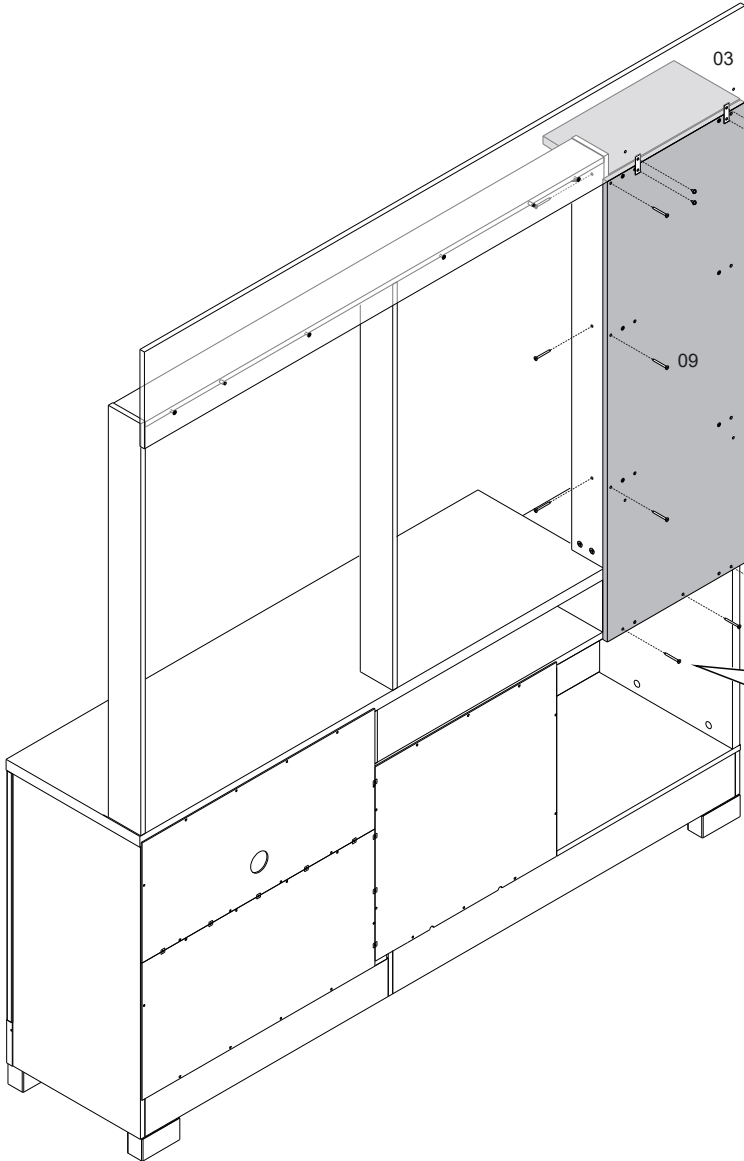
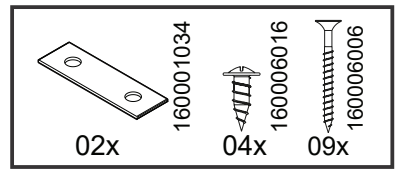

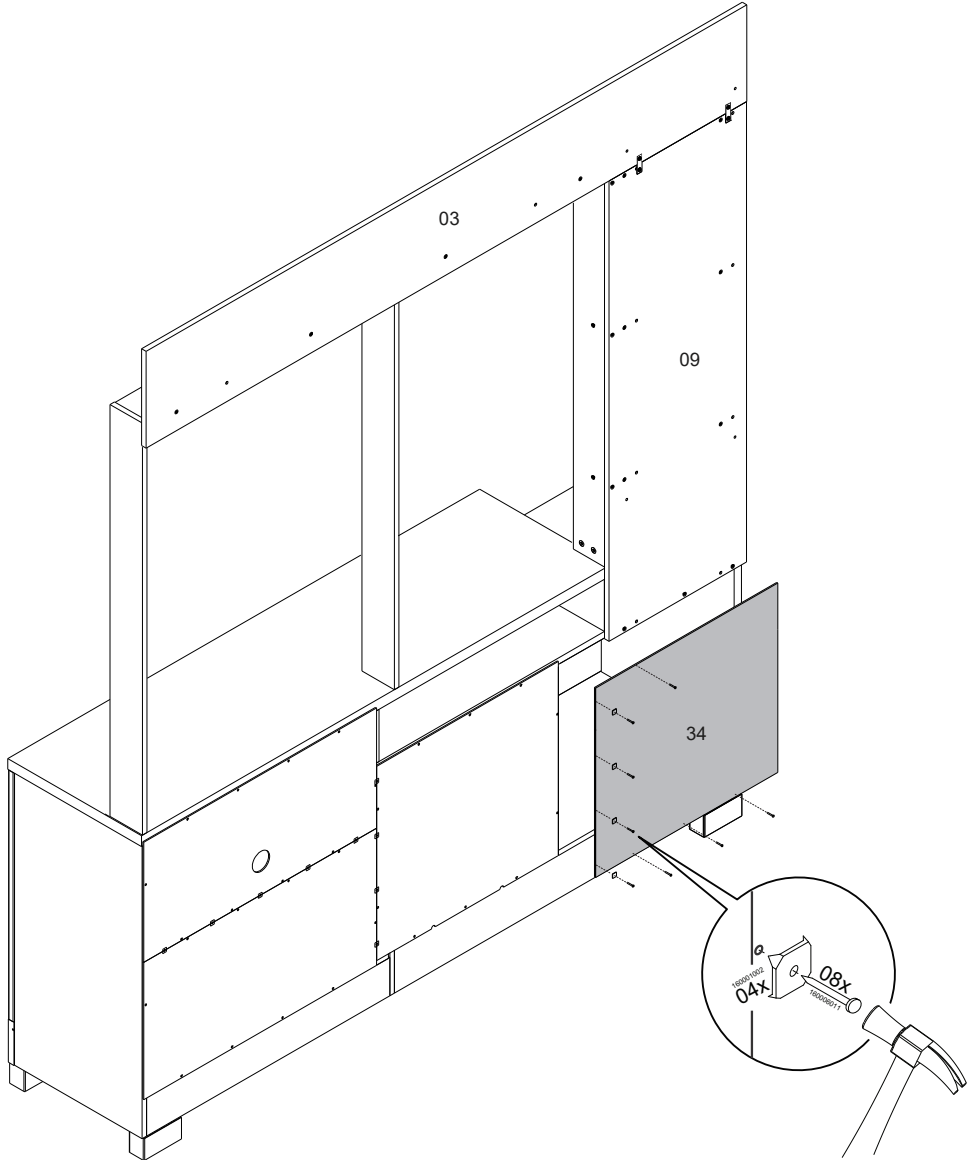
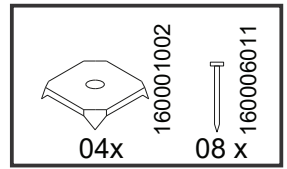

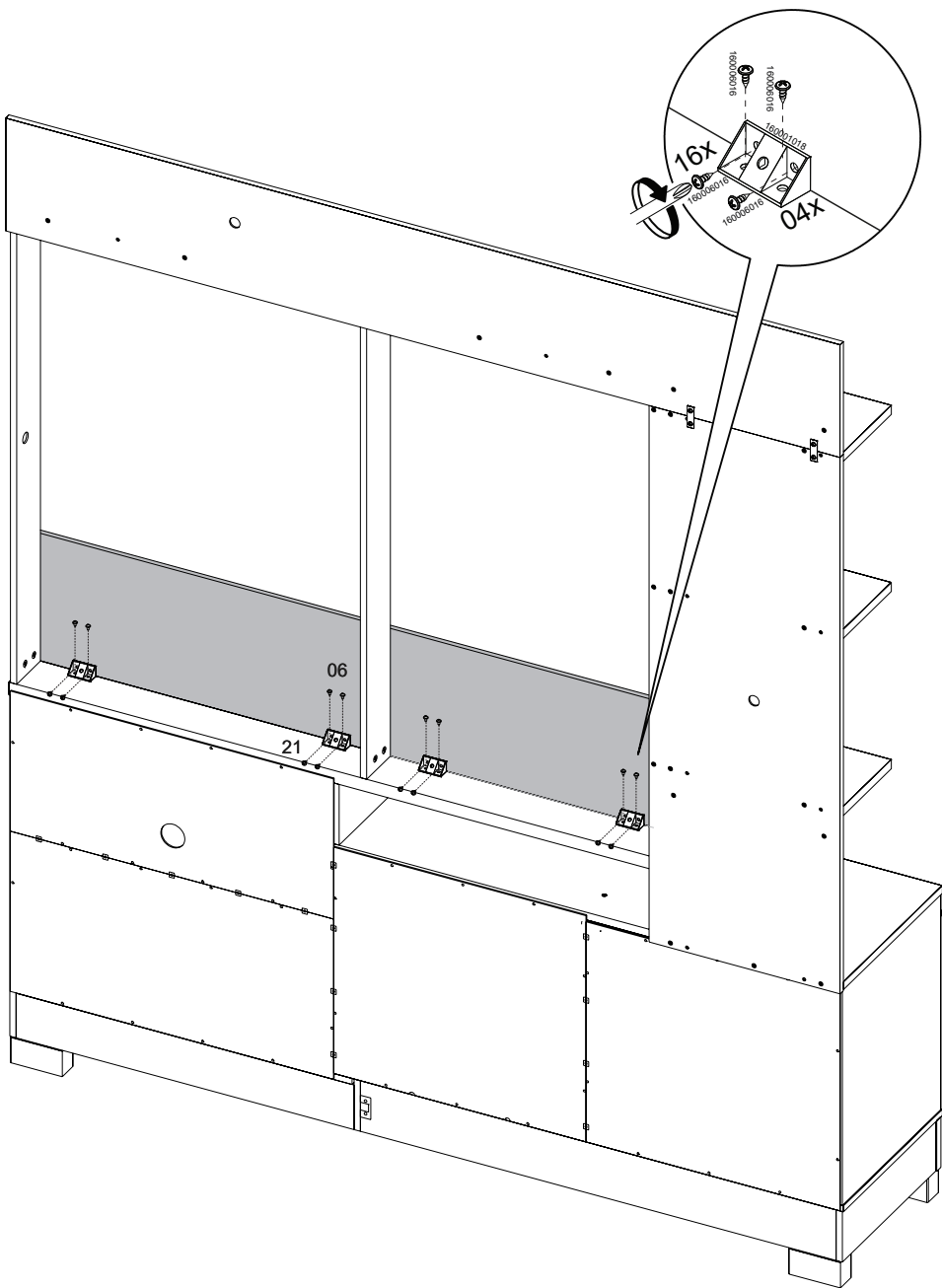
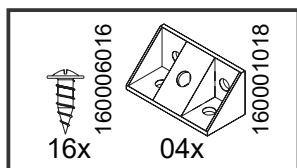

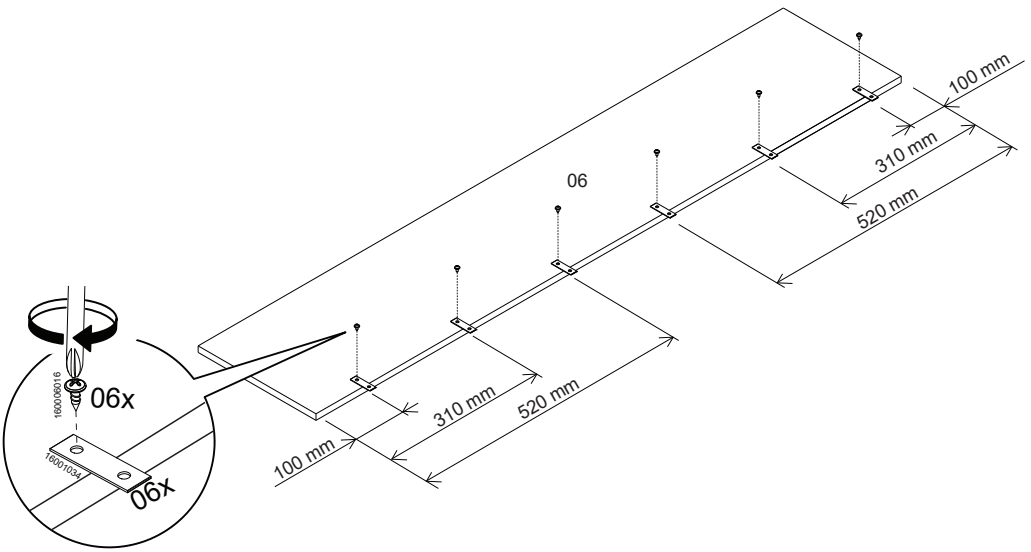
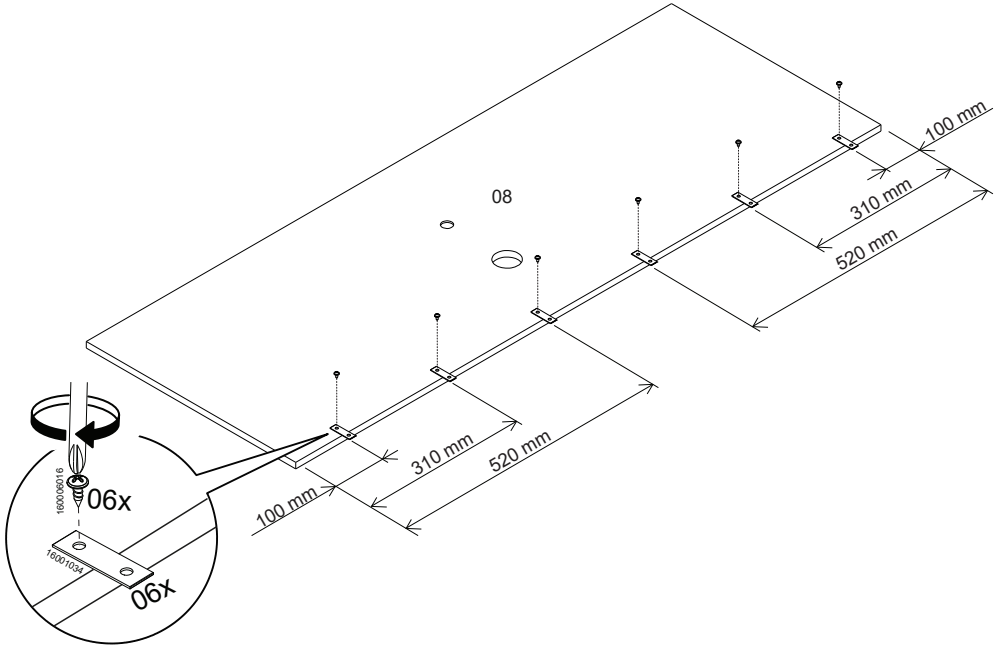
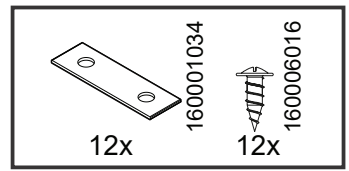

41

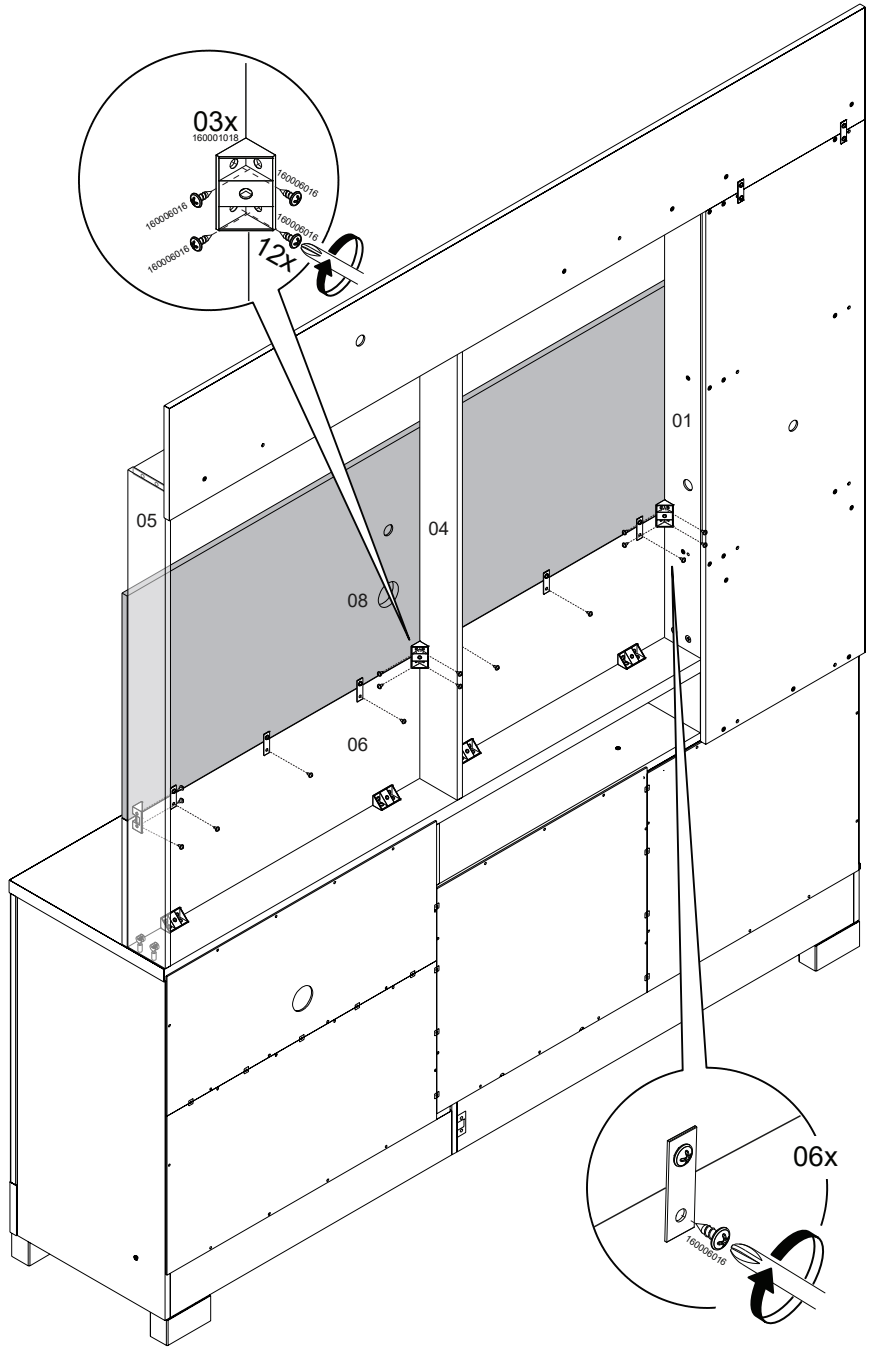
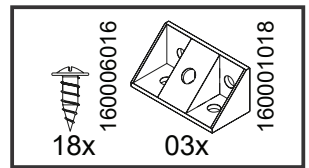

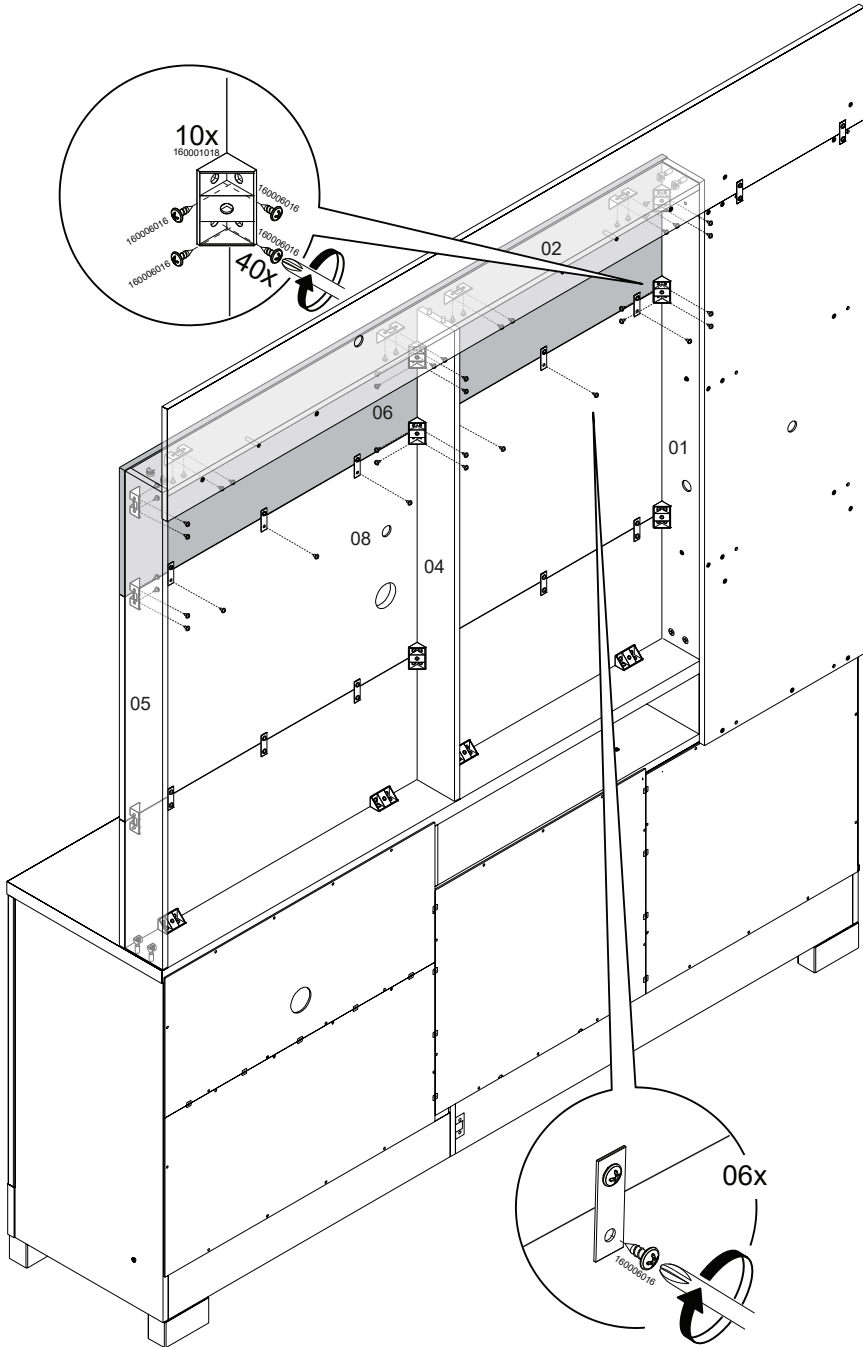
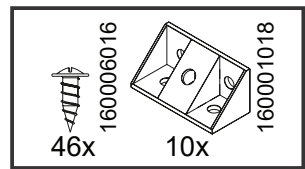

43

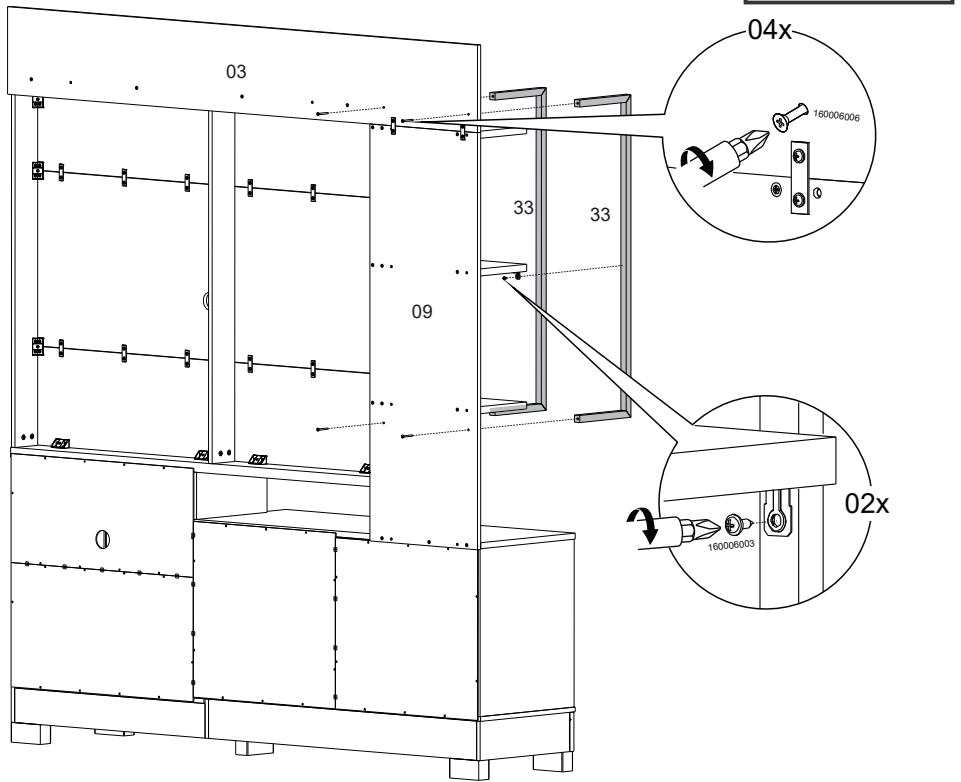

44

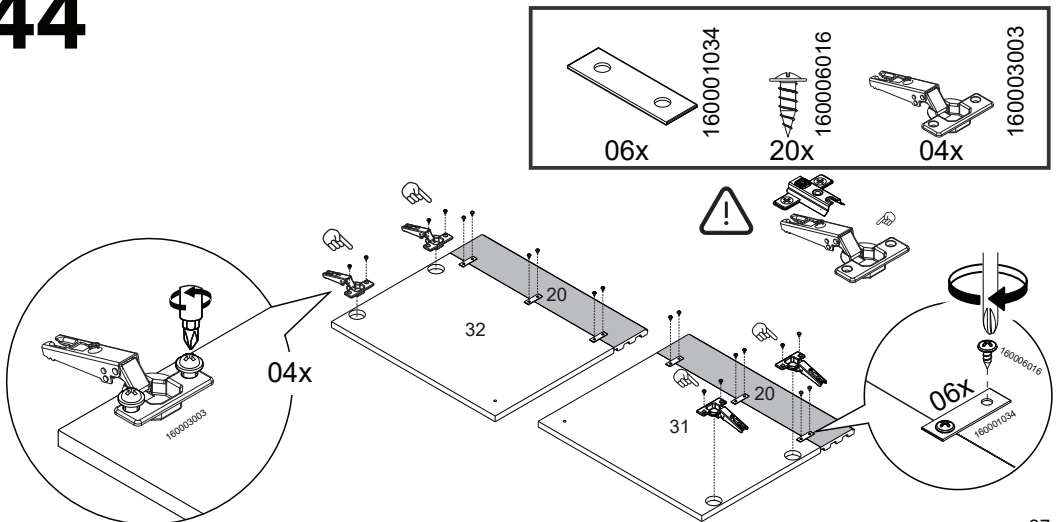

45A

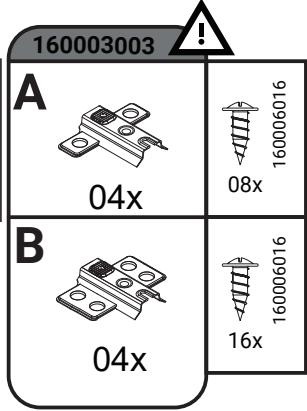
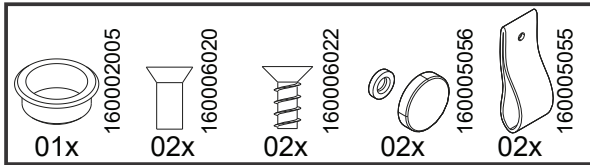

Para montagem das demais derivações, seguir passo abaixo:

For the assembly of the other colors, follow the step below:

Para el montaje de los demás colores, siga el siguiente paso:

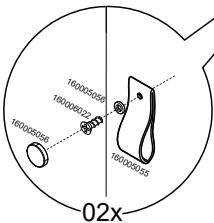
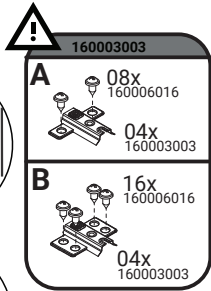
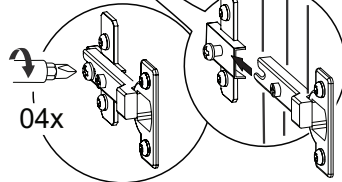
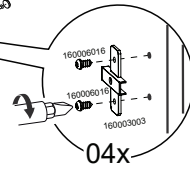
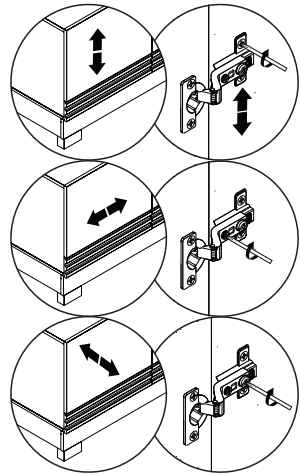
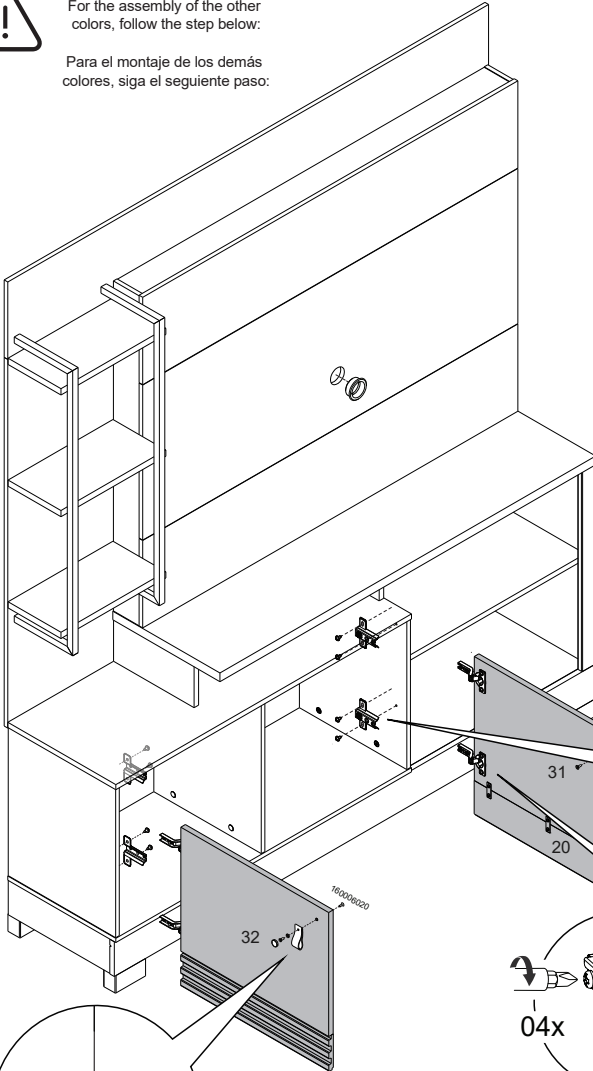
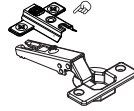

45B

Para montagem na derivação
DOURADO/OFF WHITE FOSCO,
seguir passo abaixo:



For the GOLD/OFF WHITE color
assembly, follow the step below:

Para el montaje del color
DORADO/OFF WHITE,
siga el siguiente paso:

