

GARANTIA E INSTRUÇÕES DE LIMPEZA E CONSERVAÇÃO / WARRANTY AND CLEANING AND CARE INSTRUCTIONS

Nosso produtos são garantidos por 90 dias contra defeitos de fabricação. Ao constatar um problema coberto pela garantia, entre em contato com a loja onde o produto foi comprado. Ela estará capacitada para atendê-lo da melhor forma diante de cada caso. Reclamações de garantia somente poderão ser atendidas se o termo de garantia for apresentado no ato de reivindicação, acompanhado de sua nota fiscal de compra.

Nuestros productos están garantidos contra defectos de fabricación por 90 días, a partir de la compra. Ao constatar un problema protegido por la garantía, póngase en contacto con la tienda donde se adquirió el producto. Ella estará capacitada para atenderlo de la mayor manera de acuerdo con cada caso.

Our products are guaranteed against manufacturing defects for 90 days from the date of purchase. When you find a problem covered by the warranty, please contact the store where the product was purchased. The store is able to serve you in the best way in each case.

Exclusões:
Desgaste natural ou danos causados por água, maresia, ferrugem, incêndio, calor, cupins e pragas em geral. Montagem, manutenção e uso inadequado. Não cumprimento das recomendações técnicas do esquema. Montagens e desmontagens após a primeira instalação. Instalações elétricas e outras afins.

Importante
A Linea Brasil não autoriza nenhuma pessoa, loja ou entidade assumir em seu nome qualquer outra garantia que não conste no certificado. A fabricante reserva-se no direito de efetuar nos produtos eventuais modificações que considerar necessárias, sem prejudicar as características essenciais. Os produtos terão peças de assistência para reposição no período de 1 ano a contar de sua retirada do mercado, desde que haja matéria-prima equivalente, observando o dispositivo no Art.32 da Lei 8.078/90 (Cód. Defesa do Consumidor). O atendimento para produtos fora de linha é feito por programação especial, através da loja revendedora sob aprovação de consulta prévia ao fabricante.

Exclusões:
Desgaste natural ou danos causados por água, neblina salina, óxido, fogo, calor, termitas e pragas em geral. Manutenção e uso inadequado. Incumprimento de las recomendaciones técnicas del esquema. Montaje y desmontaje tras la primera instalación. Instalaciones eléctricas y otras similares.

Importante
Linea Brasil does not authorize any person, store or entity to assume in its behalf any other warranty that does not appear on the certificate. The manufacturer reserves the right to make in the products any modifications that it considers necessary without prejudice to the essential characteristics. The products will have replacement parts within one year of being withdrawn from the market. The service for off-line products is done by special programming, through the store reseller under prior consultation with the manufacture.

Exclusões:
Natural wear and tear or damage caused by water, sea spray, rust, fire, heat, termites and pests in general. Improper assembly, maintenance and use. Failure to comply with the technical recommendations of the scheme. Assembly and disassembly after the first installation. Electrical and other related installations.

Importante
Linea Brasil does not authorize any person, store or entity to assume on its behalf any other warranty that does not appear on the certificate. The manufacturer reserves the right to make in the products any modifications that it considers necessary without prejudice to the essential characteristics. The products will have replacement parts within one year of being withdrawn from the market. The service for off-line products is done by special programming, through the store reseller under prior consultation with the manufacture.

Para retirar o pó, utilize um pano seco, espanador ou aspiradora. Se necessário, para uma limpeza mais efetiva, utilize um pano levemente umedecido com água. Finalize com uma flanela limpa e seca. Evite materiais abrasivos, umidade e calor.

Para quitar el polvo, utilice un paño seco, un plumero o una aspiradora. Si es necesario, para una limpieza más eficaz, utilice un paño ligeramente humedecido con agua. Termine con una flanela limpia y seca. Evite materiales abrasivos, humedad y calor.

To remove dust, use a dry cloth, duster or vacuum cleaner. If necessary, for more effective cleaning, use a cloth slightly dampened with water. Finish with a clean, dry flannel. Avoid abrasive materials, humidity and heat.

VOLUME	ITEM	PEÇA	DESCRIÇÃO	DIMENSÕES (mm)	QUANTIDADE	MATERIAL	TABELA DE ACESSÓRIOS TABLA DE ACCESORIOS ACCESSORIES TABLE				
Caja	Artículo	Pieza	Descripción	Dimensión	Cantidad	Material	Código Code	Descrição Description Description	Quantidade Amount		
BOX	Item	Part	Description	Dimension	Amount						
1	1	510269001	BASE BASE BASE	2154 384 15	1	MDP	A	160001002	PRENDEDOR DE FUNDOS CLIP DE FONDOS BACKGROUND CLAMP	6	
1	2	510269002	RODAPE LATERAL PIE DE PÁGINA LATERAL SIDE SKIRTING BOARD	328 100 12	2	MDP	B	160001003	CAVILHAS 8X20MM PASADORES DE 8X20MM PEGES 8X20MM	16	
2	3	510269003	RODAPE CENTRAL PIE DE PÁGINA CENTRAL CENTRAL SKIRTING BOARD	296 100 12	2	MDP	C	160001004	CAVILHAS 8X30MM PASADORES DE 8X30MM PEGES 8X30MM	3	
1	4	510269004	RODAPE FRONTAL ZÓCALO DELANTERO FRONT SKIRTING BOARD	2062 100 12	1	MDP	D	160001005	CAVILHA 8X55MM PASADOR 8X55MM PEG 8X55MM	5	
1	5	510269005	RODAPE TRASEIRO ZÓCALO TRASEIRO REAR SKIRTING BOARD	2034 100 12	1	MDP	E	160001011	SUPORE ANGULAR CENTRAL SOPORTE DE ÁNGULO CENTRAL CENTRAL ANGLE SUPPORT	6	
3	6	510269006	LATERAL LADO SIDE	373 362 12	2	MDP	F	160001012	DISPOSITIVO TRAPEZOIDAL DISPOSITIVO TRAPEZOIDAL GRAY TRAPEZOIDAL DEVICE	4	
3	7	510269007	DIVISAO DIVISION DIVISION	373 340 12	2	MDP	G	160001018	CANTONEIRA PLÁSTICA ESQUINA DE PLÁSTICO PLASTIC CORNER	24	
1	8	510269008	TAMPO INFERIOR PARTE INFERIOR SUPERIOR LOWER TOP	2154 384 15	1	MDP	H	160001023	CAVILHA 6X30MM PASADOR 6X30MM PEG 6X30MM	28	
1	9	510269009	TAMPO SUPERIOR MESA SUPERIOR UPPER TOP	2154 268 18	1	MDF	I	160001024	PINO GIROFIX PIN FIO PARA NIÑA GIROFIX PIN	36	
2	10	510269010	ENGROSSO CENTRAL ESPESOR CENTRAL CENTRAL THICKENING	128 54 12	2	MDP	J	160001025	CASTANHA DO MINI-GIROFIX MINI-GIROFIX CASTAÑO MINI-GIROFIX NUMBERS	36	
1	11	510269011	ENGROSSO LATERAL ENGRESAMENTO LATERAL SIDE THICKENING	184 54 12	2	MDP	K	160001034	CHAPA JUNCAO PLACA DE UNICAO JOINT PLATE	6	
1	12	510269012	ENGROSSO FRONTAL ESPESOR FRONTAL FRONT THICKENING	2088 54 12	1	MDP	L	160001035	CANTONEIRA METALICA ESQUINA DE METAL METAL CORNER	2	
1	13	510269013	ENGROSSO TRASEIRO ESPESOR TRASEIRO REAR THICKENING	1976 55 12	1	MDP	M	160002002	TAMPA ADESIVA CUBIERTA ADESIVA ADHESIVE COVER	16	
2	14	510269014	FUNDO CENTRAL (COM FURO) PARTE INFERIOR CENTRAL (CON AGUJERO) CENTRAL BOTTOM (WITH HOLE)	1760 400 2,8	1	MDF	N	160002003	SUPORE PRATELEIRA NYLON SOPORTE PARA ESTANTE DE NYLON NYLON SHELF SUPPORT	4	
2	15	510269015	FUNDO LATERAL LADO INFERIOR SIDE BOTTOM	692 400 2,8	2	MDF	O	160002004	SAPATA OVAL ZAPATO OVALADO OVAL SHOE	8	
1	16	510269016	TRAVESSA LATERAL BALLESTA LATERAL SIDE CROSSBOARD	1403 100 12	2	MDP	P	160002005	GUIA CABO / PASSA FIO GUÍA DE CABLES / GUÍA DE ALAMBRE CABLE GUIDE / WIRE LINE	1	
1	18	510269018	TRAVESSA CENTRAL CRUCE CENTRAL CENTRAL CROSSBOARD	1389 100 12	2	MDP	Q	160002012	GIZ DE CORRECAO TIZA CORRECTORIA CORRECTION CHALK	2	
1	19	510269019	TRAVESSA SUPERIOR TRAVESAÑO SUPERIOR UPPER CROSSBOARD	2116 100 12	1	MDP	R	160002015	BATENTE SILICONE TAPÓN DE SILICONA SILICONE STOPPER	4	
3	20	510269020	TRAVESSA APOIO CENTRAL MOLDURA MARCO DE SOPORTE CENTRAL TRAVESAÑO CENTRAL SUPPORT CROSSBOARD FRAME	650 70 15	2	MDP	S	160002016	SUPORE FIM DE CURSO APOYO DE FIN DE CURSO END OF STROKE SUPPORT	2	
3	21	510269021	TRAVESSA APOIO LATERAL MOLDURA MARCO DE SOPORTE LATERAL PARA TRAVESAÑO SIDE SUPPORT CROSSBOARD FRAME	714 70 15	4	MDP	T	160003004	KIT PORTA DE CORRER INTERNO KIT PUERTA CORREDERA INTERNA INTERNAL SLIDING DOOR KIT	2	
2	22	510269022	MOLDURA LATERAL ESQUERDA MARCO LADO IZQUIERDO LEFT SIDE FRAME	1405 147 15	1	MDF	U	160006003	PARAFUSO 3,5X14 CABECA FLANGEADA TORNILLO DE CABEZA CON BRIDA DE 3,5 X 14 FLANGED HEAD SCREW 3.5X14	2	
2	23	510269023	MOLDURA LATERAL DIREITA MARCO LATERAL DERECHO RIGHT SIDE FRAME	1405 147 15	1	MDF	V	160006006	PARAFUSO 3,5X40 CABECA CHATA TORNILLO DE CABEZA PLANA 3,5X40 FLANGE HEAD SCREW 3.5X40 FLAT	17	
3	24	510269024	MOLDURA CENTRAL ESTREITA SUPERIOR MARCO CENTRAL SUPERIOR ESTRECHO UPPER NARROW CENTRAL FRAME	293 110 15	3	MDF	W	160006008	PARAFUSO 4,5X25 CABECA CHATA TORNILLO DE CABEZA PLANA 4,5X25 SCREW 4.5X25 FLAT HEAD	94	
3	25	510269025	MOLDURA CENTRAL ESTREITA INFERIOR MARCO CENTRAL INFERIOR ESTRECHO LOWER NARROW CENTRAL FRAME	150 110 15	3	MDF	X	160006010	PARAFUSO 4,5X50 CABECA CHATA TORNILLO DE CABEZA PLANA 4,5X50 SCREW 4.5X50 FLAT HEAD	5	
2	26	510269026	MOLDURA CENTRAL LARGA SUPERIOR MARCO CENTRAL SUPERIOR ANCHO UPPER WIDE CENTRAL FRAME	293 147 15	10	MDF	Y	160006011	PREGO CLAVO NAIL	74	
2	27	510269027	MOLDURA CENTRAL LARGA INFERIOR MARCO CENTRAL INFERIOR ANCHO WIDE CENTRAL FRAME LOWER	150 147 15	10	MDF	Z	160006012	PARAFUSO 3,5X12 CABECA FLANGEADA TORNILLO DE CABEZA CON BRIDA DE 3,5 X 12 SCREW 3.5X12 FLANGED HEAD	136	
3	28	510269028	MOLDURA CENTRAL SUPERIOR (COM FURO) MARCO CENTRAL SUPERIOR (CON AGUJERO) UPPER CENTRAL FRAME (WITH HOLE)	293 120 15	1	MDF	AA	160006018	PARAFUSO 4,5X22 CABECA CHATA TORNILLO DE CABEZA PLANA 4,5X22 SCREW 4.5X22 FLAT HEAD	26	
3	29	510269029	MOLDURA CENTRAL INFERIOR (COM FURO) MARCO CENTRAL INFERIOR (CON AGUJERO) LOWER CENTRAL FRAME (WITH HOLE)	150 120 15	1	MDF	AB	160006021	PARAFUSO 4,5X35 CABECA FLANGEADA TORNILLO 4,5X35 CABEZA BRIDADA SCREW 4.5X35 FLANGED HEAD	20	
2	30	510269030	TRAVESSA APOIO SOPORTE DE TABLERO TRAVESAÑO SUPPORT CROSSBOARD	962 70 15	2	MDP	AC	160006044	PARAFUSO M4 20MM CABECA CHATA TORNILLO M4 CABEZA PLANA 20MM SCREW M4 20MM FLAT HEAD	2	
2	31	510269031	PRATELEIRA SUPERIOR ESTANTE SUPERIOR UPPER SHELF	1954 145 25	1	MDP	AD	160010025	▲ KIT FITA LED (OPCIONAL) KIT TIRA LED (OPCIONAL) LED STRIP KIT (OPTIONAL) ▲	1	
2	32	510269032	TRAVESSA LED CENTRAL TRAVESAÑO CENTRAL LED CENTRAL LED CROSSBOARD	842 71 12	2	MDP	AE	160012031	TRIO PVC PISTA DE PVC PVC TRACK	2	
2	33	510269033	TRAVESSA LED LATERAL BALLESTA LATERAL LED SIDE LED CROSSBOARD	1006 70 12	2	MDP					
2	34	510269034	PAINEL TV SUPERIOR PANEL SUPERIOR DE TV UPPER TV PANEL	1954 513 12	1	MDP					
2	35	510269035	PAINEL TV INFERIOR (COM FURO) PANEL INFERIOR DE TV (CON AGUJERO) LOWER TV PANEL (WITH HOLE)	1954 513 12	1	MDP					
2	36	510269036	TRAVESSA LED SUPERIOR INFERIOR TABLERO TRAVESAÑO LED SUPERIOR INFERIOR UPPER LED CROSSBOARD LOWER	1794 70 12	2	MDP					
1	37	510269037	PRATELEIRA MÓVEL ESTANTE MÓVIL MOBILE SHELF	747 338 15	1	MDP					
3	38	510269038	PORTA PUERTA DOOR	718 366 15	2	MDP					

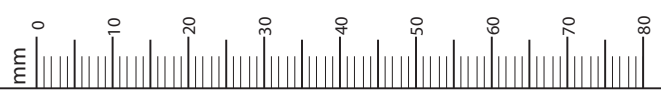

01

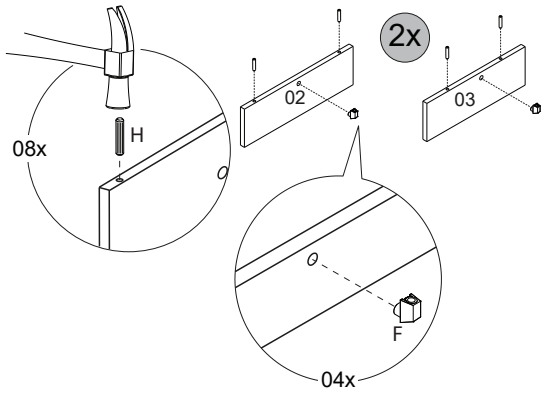

- F 04x
- H 08x

02

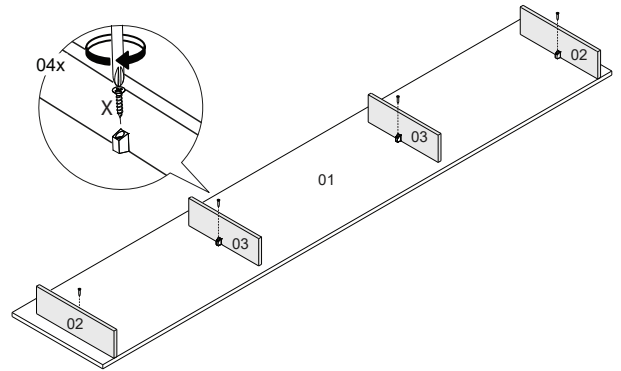

- X 04x

03

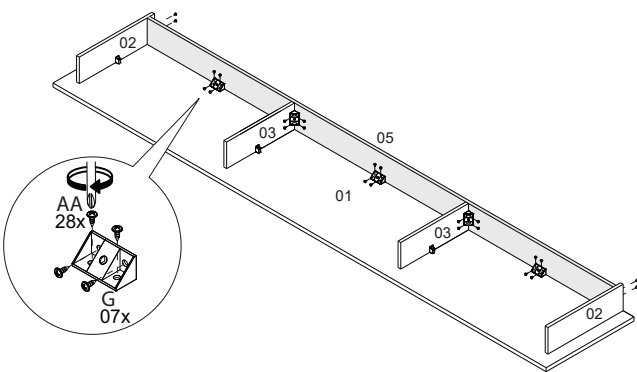

- G 07x
- AA 28x

04

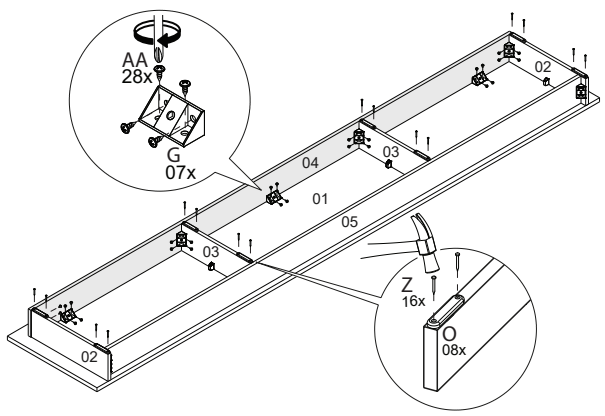

- G 07x
- O 08x
- Z 16x
- AA 28x

05

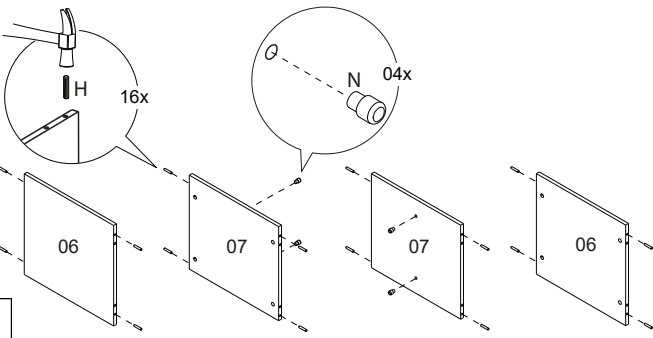

- H 16x
- N 04x

06

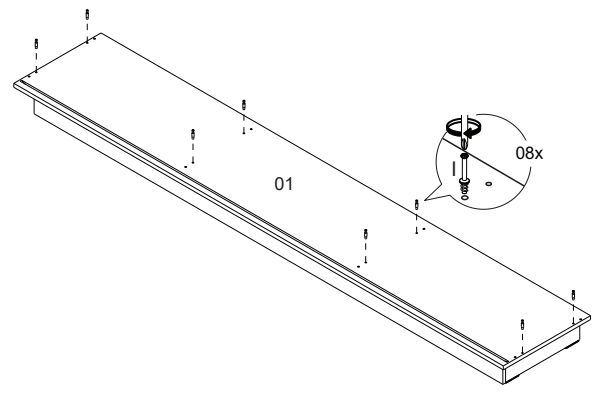

- I 08x

07

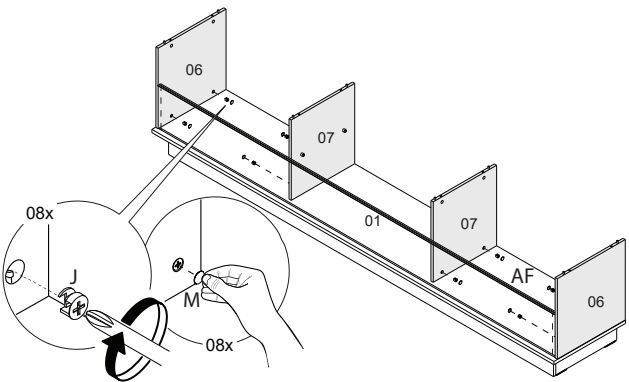

- J 08x
- M 08x
- AF 01x

08

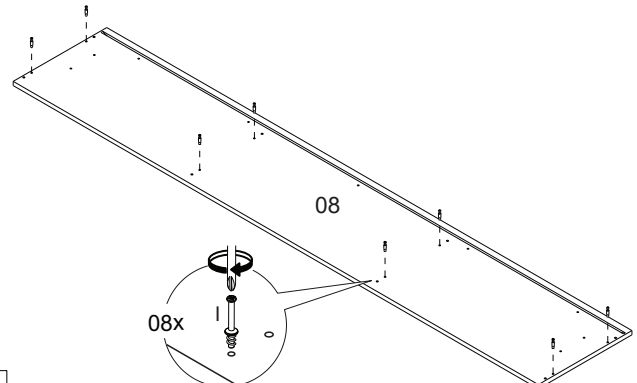

- I 08x

09

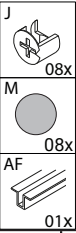
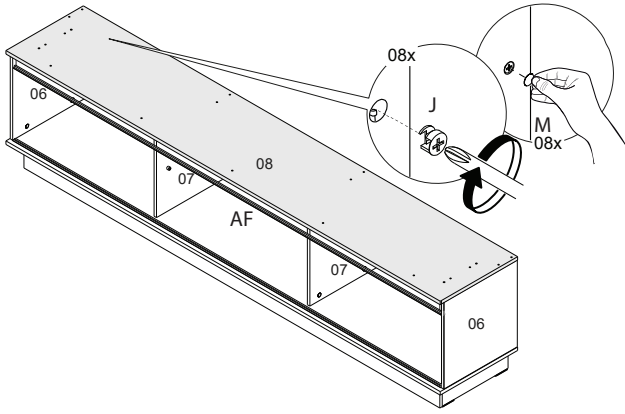

10

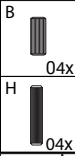
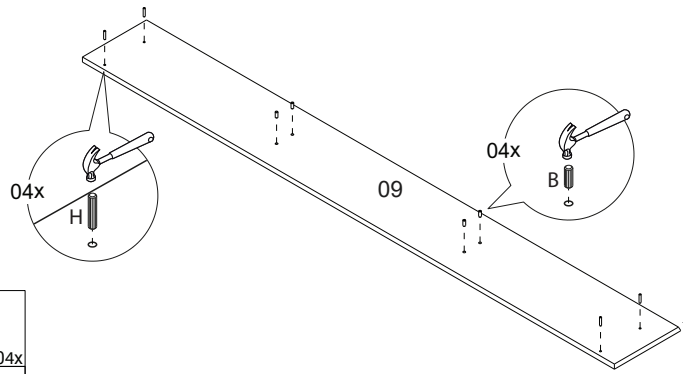

11

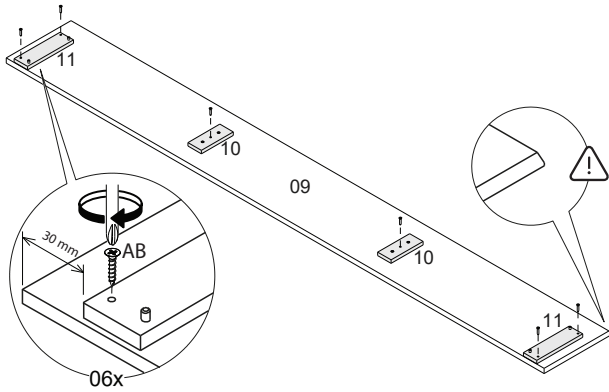

12

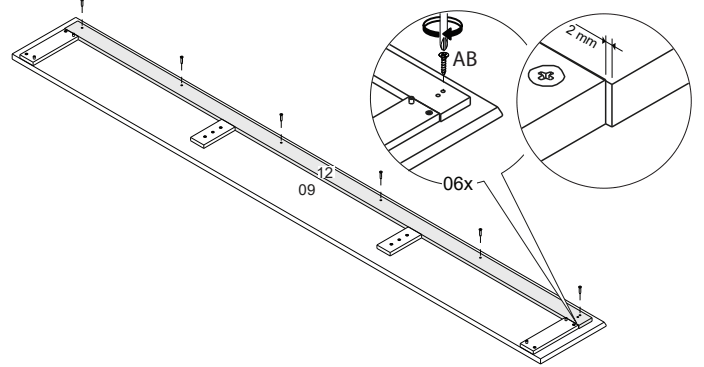

13

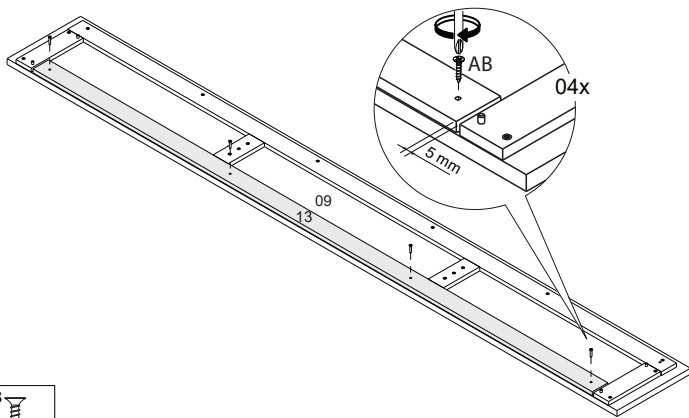

14

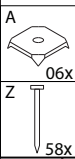
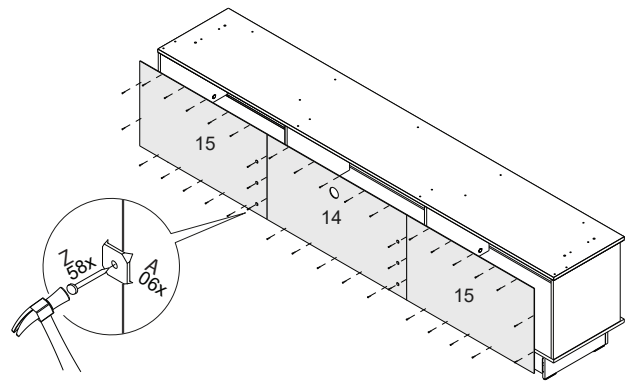

15

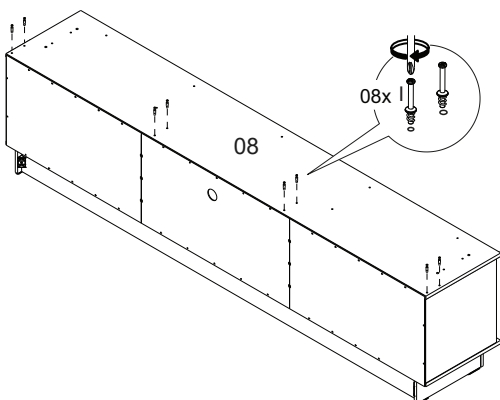

16

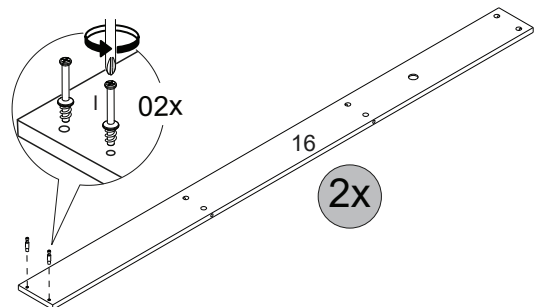

25

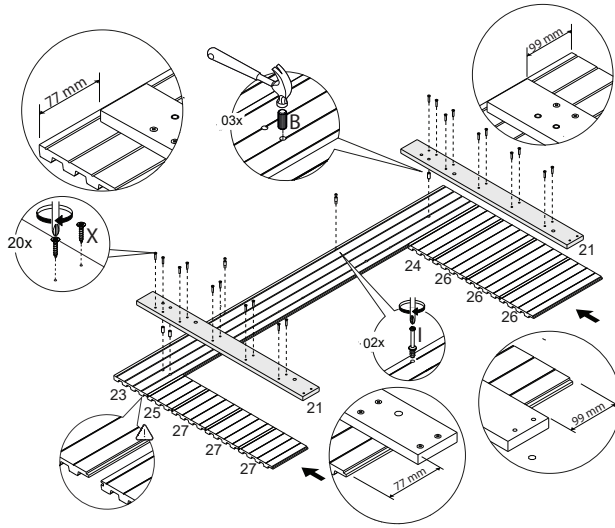

- B 03x
- I 02x
- X 20x

26

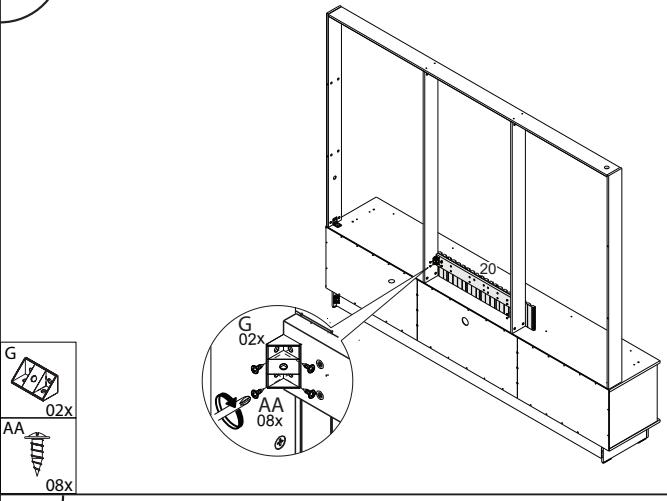

- G 02x
- AA 08x

27

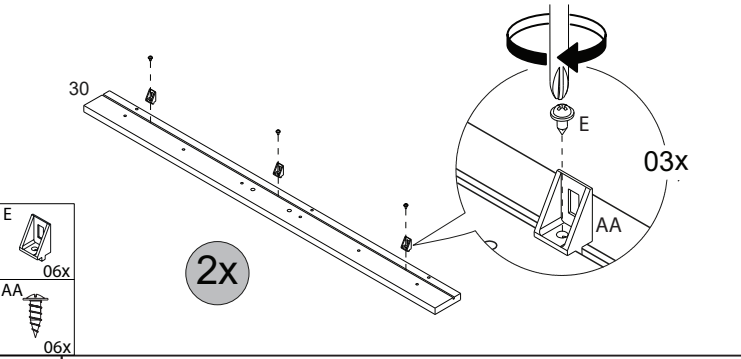

- E 06x
- AA 06x

28

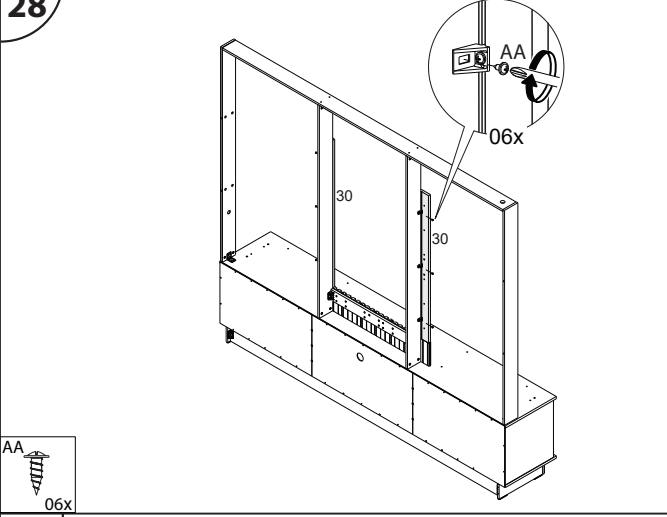

- AA 06x

29

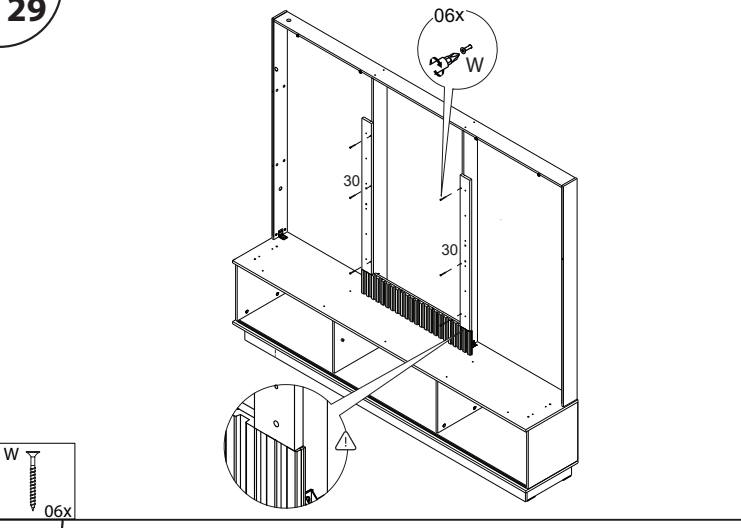

- W 06x

30

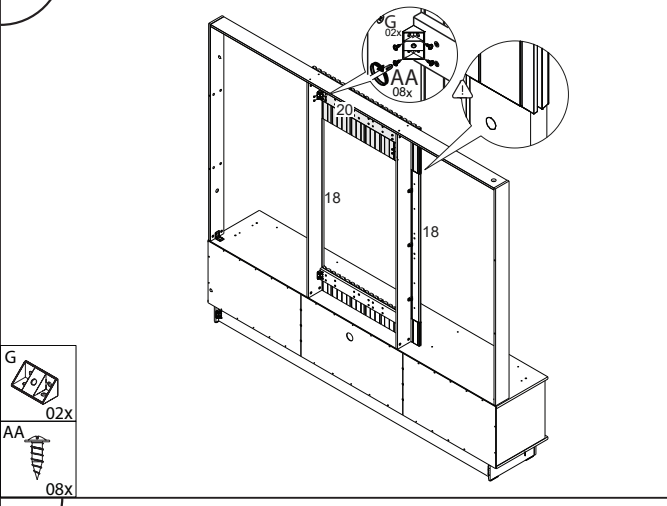

- G 02x
- AA 08x

31

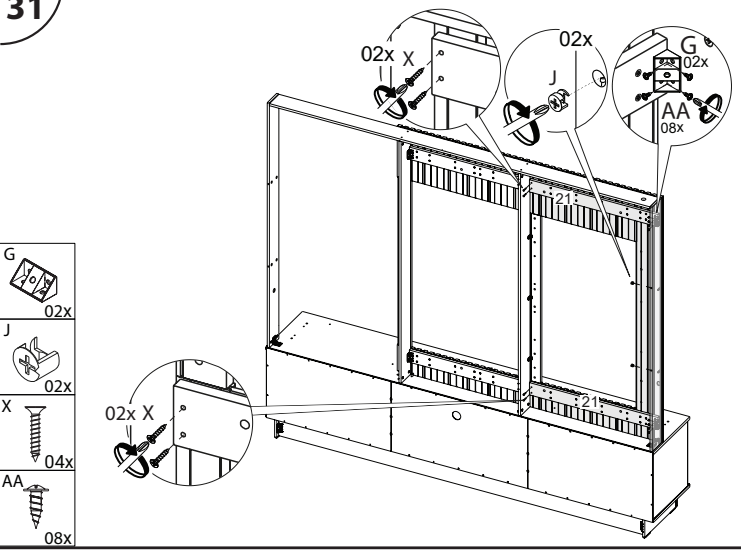

- G 02x
- J 02x
- X 04x
- AA 08x

32

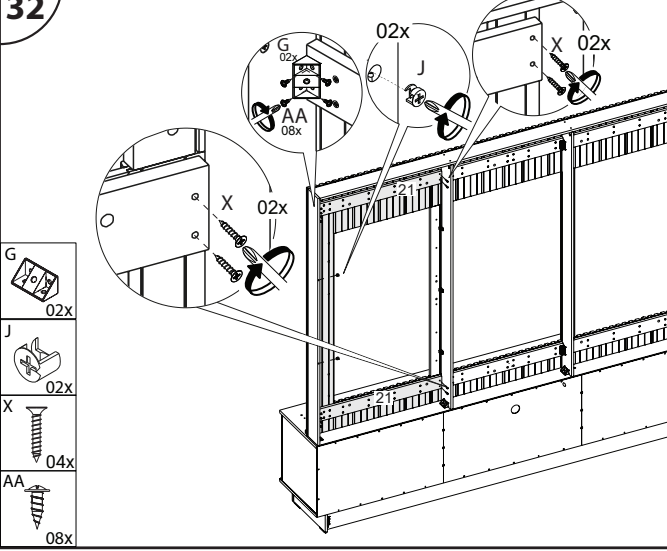

- G 02x
- J 02x
- X 04x
- AA 08x

33

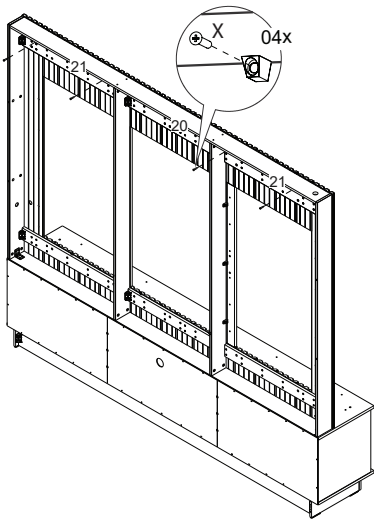

34

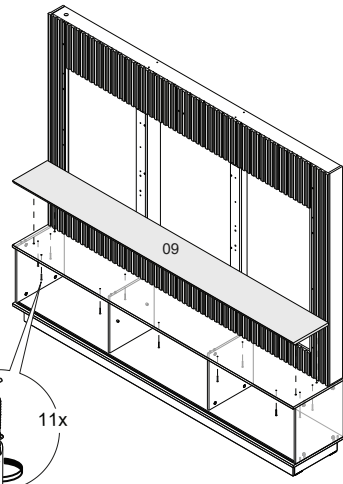

35

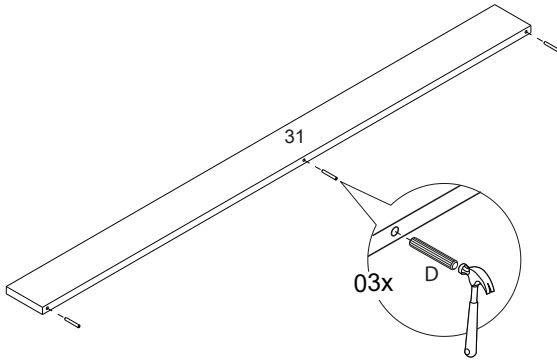

36

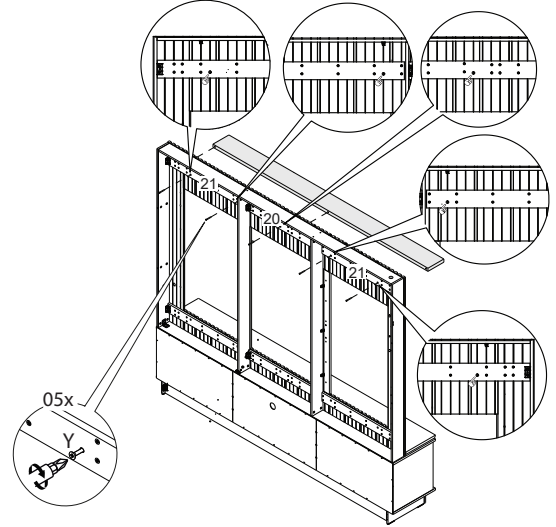

37

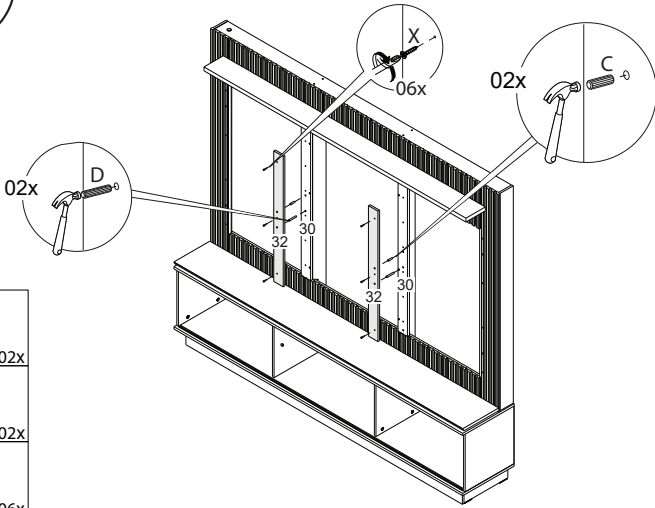

38

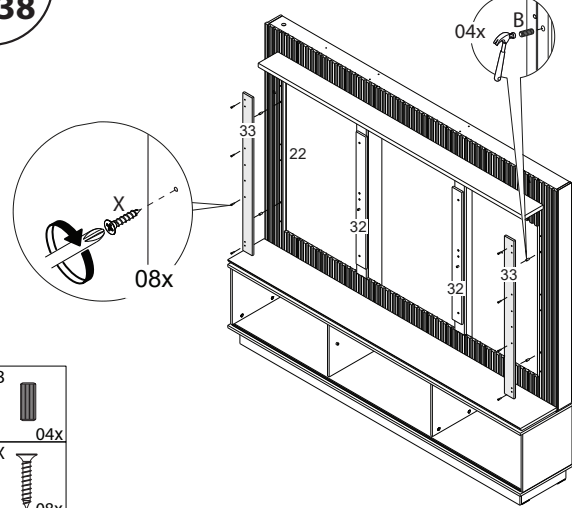

39

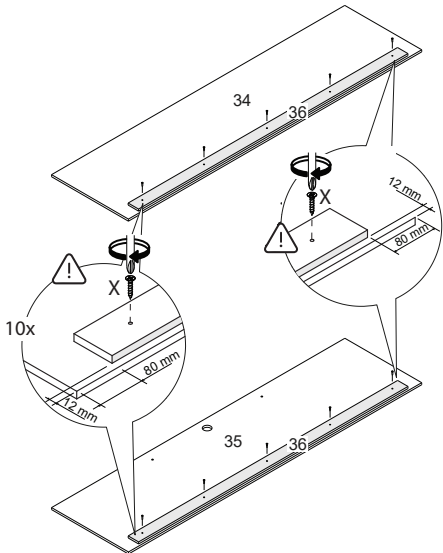

40

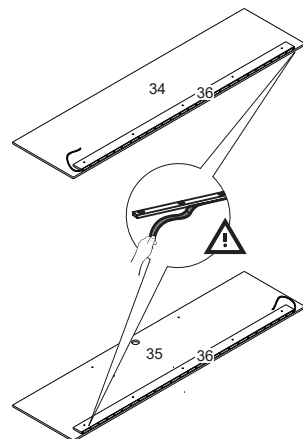

41

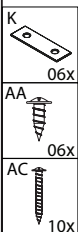
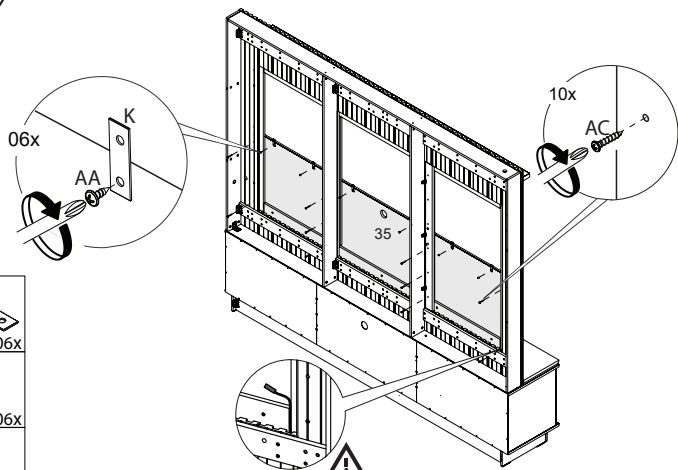

42

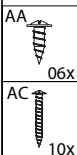
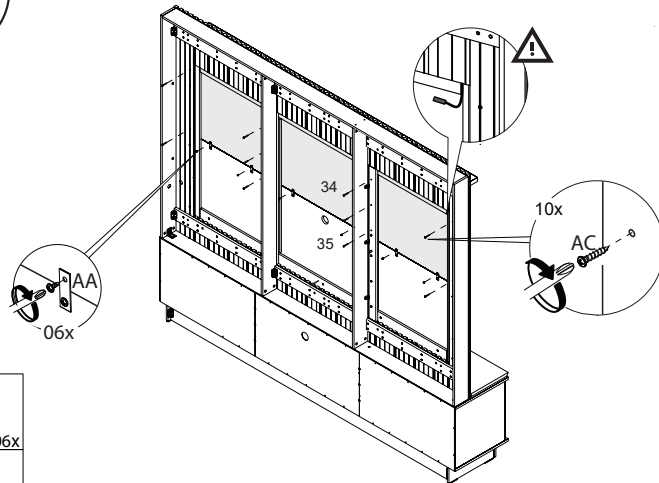

43

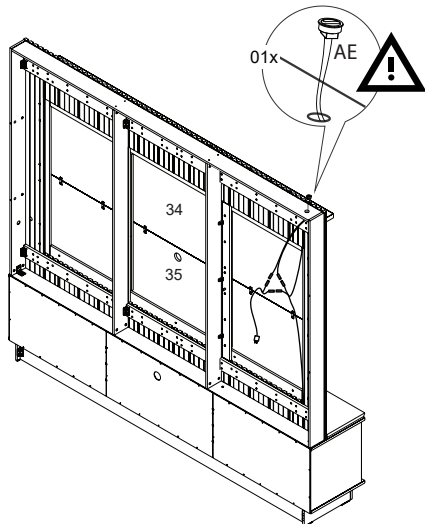

44

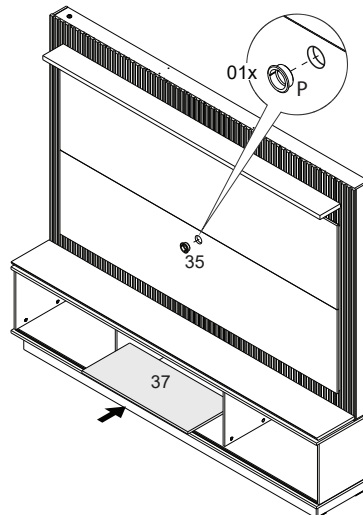

45

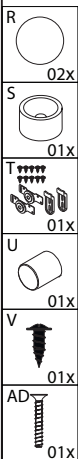
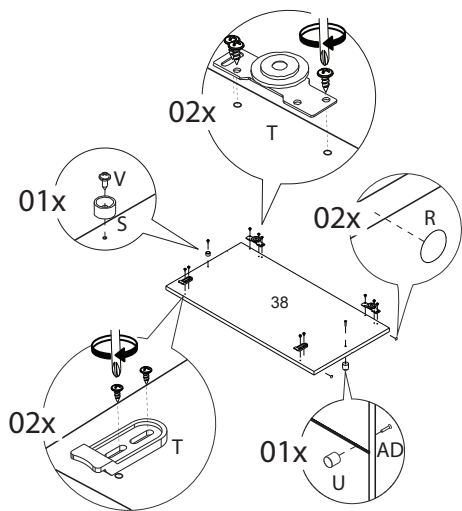

46

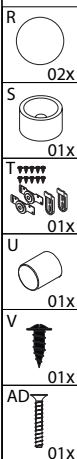
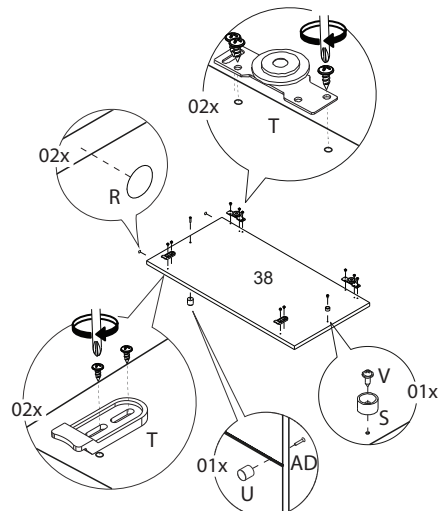

47

